



**Modular Cooking Range Line
S90 Worktop with water mixing
unit 4", Island Installation**

ITEM # _____

MODEL # _____

PROJECT NAME # _____

SIS # _____

AIA # _____



**Modular Cooking Range Line
S90 Worktop with water mixing unit 4",
Island Installation**

584165 S90 Worktop with water mixing unit 4",
Island Installation

Short Form Specification

Item No. _____

Unit to be Electrolux S90 4" (100 mm) worktop with water mixing unit. Unit to be installed in island type installations with operations from both sides. Body and internal structure of unit entirely in 304 Stainless steel. Unit to be installed between other S90 modular units. "Lasertec" connection system permits units to be connected to each other creating a seamless work top.

Covered by Electrolux Platinum Star™ Service Program two-year parts and one-year labor warranty, installation start-up and performance check-up after one year from installation.

Main features

- Unit for island type installations with operations by chef from both sides.
- Water mixing unit for hot and cold water.
- Stainless steel top is reinforced to provide a heavy duty work surface under any load.
- Heavy duty internal frame in 304 type Stainless steel.
- Unit installed between other S90 modular units.
- "Lasertec connection system" creates seamless work top when units are connected to each other.



Approval: _____

Electrolux Professional, Inc.

www.electroluxusa.com/professional

3225 SW 42nd Street, Fort Lauderdale, Florida, 33312 • Telephone Number: 866-449-4200 • Fax Number: 954-327-6789



Electrolux

S90 Worktop with water mixing unit 4", Island Installation

Modular Cooking Range Line

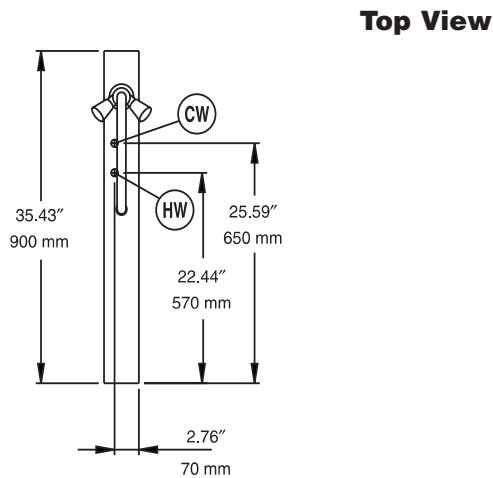
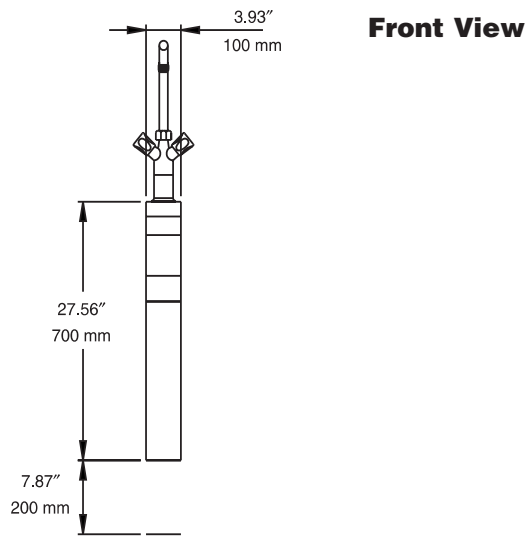

HW = Hot Water Inlet
CW = Cold Water Inlet

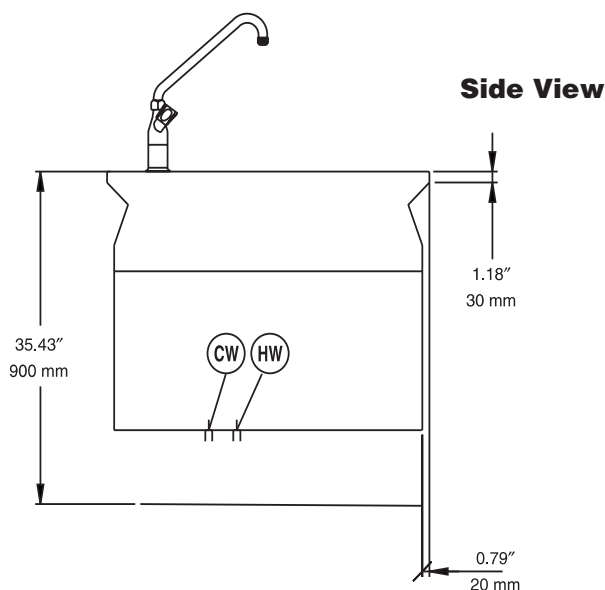

Water

Incoming Hot Water line size: 1/2"

Incoming Cold Water line size: 1/2"

Key Information

Net weight:	110 lb (50 kg)
Shipping weight:	154 lb (70 kg)
Shipping width:	11-13/16" (1200 mm)
Shipping height:	43-5/16" (1100 mm)
Shipping depth:	43-5/16" (1100 mm)
Shipping volume:	12.71 cu.ft (0.36 m ³)