

767-SK/III Low Temperature Smoker Oven



• Halo Heat . . . a controlled, uniform heat source that maintains close temperature tolerances throughout the cooking and holding function. Offers uniform and consistent cooking on a daily basis, low shrinkage of bulk or portion-cut protein items, higher food moisture content, and significantly longer holding life.



- Cooks, roasts, re-heats, smokes and holds in the same cabinet with set-and-forget controls to provide a better distribution of work loads.
- Smokes with real wood chips — no pressure cooking, no artificial smoke flavor.
- Smoke timer offers a choice of mild, medium, or heavy smoke flavor.
- Cold smokes fish and cheese.
- Cooks by time or by probe to sense internal product temperature and automatically converts from cook mode to hold mode once the set parameters have been reached.
- Eight programmable menu buttons store favorite recipes into memory (cook/hold/time/probe set-points). Reduces operational requirements to simply loading the oven, pushing the power button, the preset menu button, and start.
- When cooking by probe, the oven maintains a record of the highest and lowest temperatures sensed by the food probe to assure foods are cooked to the temperature required.
- Oven includes the patented SureTemp™ heat recovery system to assure immediate compensation for any heat loss whenever the door is opened and provides an audible reminder if the door has been left open for more than three minutes.
- Antimicrobial handle retards the growth of illness-causing pathogens.

Short Form Spec

Alto-Shaam single compartment 767-SK/III Smoker oven is constructed with a stainless steel exterior. Oven includes a stainless steel door with magnetic latch. Oven interior includes two (2) completely removable, non-magnetic stainless steel side racks with eleven (11) pan positions spaced on 1-3/8" (35mm) centers, two (2) stainless steel wire shelves, one (1) stainless steel rib rack, a removable stainless steel drip pan with drain and a wood chip container. Oven is furnished with an exterior, front mounted stainless steel drip tray and one (1) sample bag each of cherry, hickory, apple, and maple wood chips. Oven includes one (1) set of 3-1/2" (89mm) casters — 2 rigid, and 2 swivel with brake.

Deluxe control includes a 4 digit LED display, On/Off button, cook temperature button with an adjustable cook range from 200°F to 325°F (93°C to 162°C); cook time control button with set-points from 1 minute to 24 hours; smoke time control button with set-points from 1 minute to 1 hour; probe control button with adjustable set-points between 50°F and 195°F (10°C to 91°C); and hold temperature button with an adjustable hold range from 60°F to 205°F (15°C to 96°C). Control includes eight (8) programmable menu buttons with locking capability along with the ability to set individual cook and hold parameters; hold mode count-up timer, indicator lights for operation status; and start button. The control has a built-in lock out feature and is equipped with a voltage conversion feature to match the line voltage provided by the electric power supplier.

Model 767-SK/III: Low temperature smoker oven with deluxe control.



Factory-Installed Options

- Door Choices
 - Solid Door, standard
 - Window Door, optional
- Door Swing Choices
 - Right-hand swing, standard
 - Left-hand swing, optional
- Voltage Choices:
 - 208-240V
 - 230V
- Exterior Panel Color Choices:
 - Stainless steel, standard
 - Burgundy, optional
 - Custom, optional
- Cooking thermostat limit set at 250°F for restricted areas of the U.S.A.
 - Specify on order as required
- Extended drip tray (not available with bumper)

ANSI/NF 4



IP X3



Additional Features

- HACCP Documentation, Data Logger [5015563]
 - On board Datalogger technology maintains accurate and timely recordkeeping
 - Register start time and end time
 - Register start temperature and end temperature
 - Interim time and temperature reporting is captured at 5 minute intervals
 - USB downloads facilitate record keeping on department management PC's
 - Electronic HACCP record keeping can be imported into Excel or other similar software for use in report writing and charting
 - Controller will retain the latest information for 30 days
 - Will record the product preset name (A-H) if a preset is used

- Rib Rack Shelf • Item SH-2743**

Special non-magnetic stainless steel wire shelf designed to hold ribs or fish in an upright position for more even smoking. Each shelf will hold thirteen full ribs. One (1) rib rack shelf is furnished with each smoker. Additional racks are available as an option. Total oven capacity: Two (2) rib rack shelves.

- **Stackable Design**

Stackable with 750 or 767 Series single compartment ovens and holding cabinets, or CTX4-10 Combitherm®. Order appropriate stacking hardware.

**Lifetime
Warranty**

On all Cook & Hold heating elements (excludes labor).



W164 N9221 Water Street • P.O. Box 450 • Menomonee Falls, Wisconsin 53052-0450 • U.S.A.
Phone: 262.251.3800 800.558.8744 U.S.A./CANADA Fax: 262.251.7067 800.329.8744 U.S.A. only
www.alto-shaam.com



767-SK/III

Low Temperature Smoker Oven

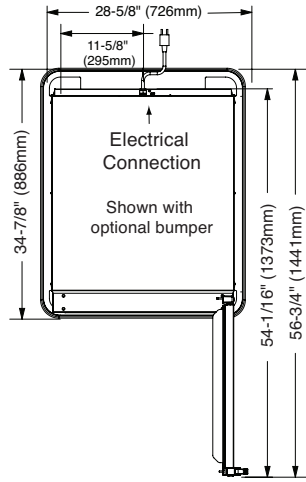

Cord Length
230V - 8 ft. (2438mm)
208-240V - 6 ft. (1829mm)

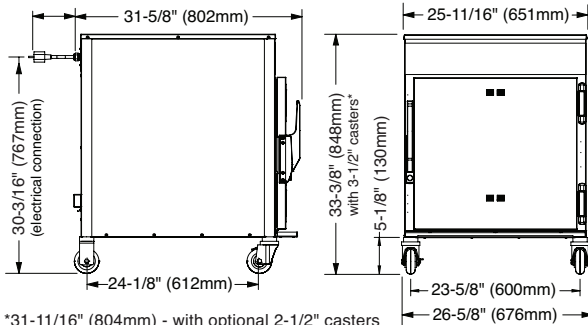

*31-11/16" (804mm) - with optional 2-1/2" casters
*35-1/16" (890mm) - with optional 5" casters
*33-13/16" (858mm) - with optional 6" legs

Dimensions: H x W x D

Exterior:

33-3/8" x 26-5/8" x 31-5/8"
(848mm x 676mm x 802mm)

Interior:

20-1/16" x 22" x 26-1/2"
(510mm x 559mm x 673mm)

Electrical

| V | Ph | Hz | A | kW | | | |
|-----|---------|-------|---------|-----|------------------|--|-------------|
| 208 | 1 | 60 | 16.0 | 3.9 | Cord, no plug | | |
| 240 | 1 | 60 | 18.5 | 4.4 | | | |
| 230 | 1 | 50/60 | 14.0 | 3.1 | Plugs rated 250V | | |
| | CEE 7/7 | | CH2-16P | | BS 1363 | | AS/NZS 3112 |

Product\Pan Capacity

100 lb (45 kg) maximum

Volume maximum: 53 quarts (67 liters)

| | Full-size pans: | Gastronorm 1/1: |
|-----------|--------------------|-------------------------|
| Nine (9) | 20" x 12" x 2-1/2" | (530mm x 325mm x 65mm) |
| Seven (7) | 20" x 12" x 4" | (530mm x 325mm x 100mm) |

Full-size sheet pans:

Up to Five (5)* 18" x 26" x 1" on wire shelves only

*additional shelves required

Clearance Requirements

| | |
|--------------------|---|
| Rear | 3" (76mm) from non-heated surfaces 18" (457mm) from heat producing equipment |
| Top | 2" (51mm) |
| Left, Right | 1" (25mm) |

Weight

Net: 190 lb (86 kg) **Ship:** 283 lb (128 kg)

Carton dimensions: (L x W x H)

35" x 35" x 41" (889mm x 889mm x 1041mm)

Installation Requirements

- Oven must be installed level.
 - The oven must not be installed in any area where it may be affected by steam, grease, dripping water, extreme temperatures, or any other severely adverse conditions.
 - Appliances with casters and no cord or plug must be secured to the building structure with a flexible connector.
- Not factory supplied.**
- Smoker ventilation requirements to be determined by local installation codes.

Accessories

| | | | |
|---|----------|--|----------|
| <input type="checkbox"/> Bumper, Full Perimeter (not available with 2-1/2" casters) | 5010371 | <input type="checkbox"/> Security Panel w/ Key Lock | 5013936 |
| <input type="checkbox"/> Carving Holder, Prime Rib | HL-2635 | <input type="checkbox"/> Shelf, Stainless Steel, Flat Wire | SH-2324 |
| <input type="checkbox"/> Carving Holder, Steamship (Cafeteria) Round | 4459 | <input type="checkbox"/> Shelf, Stainless Steel, Rib Rack | SH-2743 |
| Casters, Stem - 2 rigid, 2 swivel w/brake | | Stacking Hardware | |
| <input type="checkbox"/> 5" (127mm) | 5004862 | <input type="checkbox"/> Over or under TH, SK, S-Series | 5004864 |
| <input type="checkbox"/> 2-1/2" (64mm) | 5008022 | <input type="checkbox"/> Under CTX4-10 Combitherm® | 5019679 |
| <input type="checkbox"/> Door Lock with Key | LK-22567 | Wood Chips bulk pack - 2.5 cubic ft., 50 lb (23 kg) | |
| <input type="checkbox"/> Drip Pan with Drain, 1-11/16" (43mm) deep | 14831 | <input type="checkbox"/> Apple | WC-37747 |
| <input type="checkbox"/> Drip Pan without Drain, 1-5/8" (41mm) deep | 1014684 | <input type="checkbox"/> Cherry | WC-37746 |
| <input type="checkbox"/> Pan Grid, Wire, 16-3/8" x 24-3/8" (416mm x 619mm) | | <input type="checkbox"/> Hickory | WC-37749 |
| – fits inside of an 18" x 26" sheet pan | PN-2115 | <input type="checkbox"/> Maple | WC-37748 |



W164 N9221 Water Street • P.O. Box 450 • Menomonee Falls, Wisconsin 53052-0450 • U.S.A.
Phone: 262.251.3800 800.558.8744 U.S.A./Canada Fax: 262.251.7067 800.329.8744 U.S.A. only
www.alto-shaam.com