

ASC-4E

THE PLATINUM SERIES

ELECTRIC CONVECTION OVEN



ASC-4E

WITH OPTIONAL STATIONARY OVEN STAND
AND PAN RACK WITH SHELVES - 5003489

- Superior baking and roasting capability.
- A dependent 60/40 door system includes solid stainless steel doors and a double pane thermal window door to view the lighted oven interior.
- Both doors open beyond a 120° angle for easier loading; include a spring-loaded roller assembly to provide a positive, pressure-lock seal; and a heavy-duty door hinging system.
- Solid welded construction with stainless steel front, top, left and right sides. Rear enclosure panel is made with corrosion resistant coated steel.
- Removable oven baffle provides easy cleaning.
- Heavy-duty 3/4 hp, two-speed motor provides a fan speed for high volume production or delicate baking.
- Easy to clean porcelain enamel oven interior is standard.
- 10 kW element.
- Durable, low maintenance stainless steel door gaskets.

The Platinum Series electric convection oven features solid welded construction and an angle iron frame. The oven interior is constructed of porcelain enamel with coved corners, and a heavy duty, 14 gauge bottom liner. It is supplied with six (6) chrome plated wire shelves with 2 removable side racks and 12 shelf positions spaced at 1-3/4" (43mm). The oven is furnished with two interior lights, a 10,000 watt heating element and a heavy duty, 3/4 hp, two-speed fan motor. Control includes a 100°F to 500°F (38°C to 260°C) thermostat and a 60 minute count-down timer. The control features a oven cool-down function, oven-ready indicator light, and produces an audible signal when time has expired. The oven is supplied with 25" (635mm) legs with bullet feet.

- ASC-4E - Manual control, porcelain enamel interior
-
- ASC-4Ee - Electronic control with food probe, porcelain enamel interior
-

FACTORY INSTALLED OPTIONS



- Electrical Choices
 - 208V, 1 Phase
 - 240V, 1 Phase
 - 208V, 3 Phase
 - 240V, 3 Phase
 - 440V, 3 Phase
 - 480V, 3 Phase
 - 220V, 1 Phase
- Interior Panel Choices
 - Porcelain, standard
 - Stainless Steel, optional
- Door Choices
 - Window, standard
 - Solid, optional
- Leg Choices
 - 25" (635mm) Bullet Feet, standard [5003784]
 - 25" (635mm) Seismic Feet, optional [5003785]
 - 6" (152mm) Seismic Feet, optional [5003795]
 - 6" (152mm) Bullet Feet, optional [5003794]
- Security Device for correctional facility use
 - Package includes security back panel, door locking hasp (padlock not included), security screw package, security control cover [5020688]



W164 N9221 Water Street • P.O. Box 450 • Menomonee Falls, Wisconsin 53052-0450 • U.S.A.

PHONE: 262.251.3800 800.558.8744 U.S.A./CANADA FAX: 262.251.7067 800.329.8744 U.S.A. ONLY

www.alto-shaam.com





ASC-4E

ELECTRIC CONVECTION OVEN

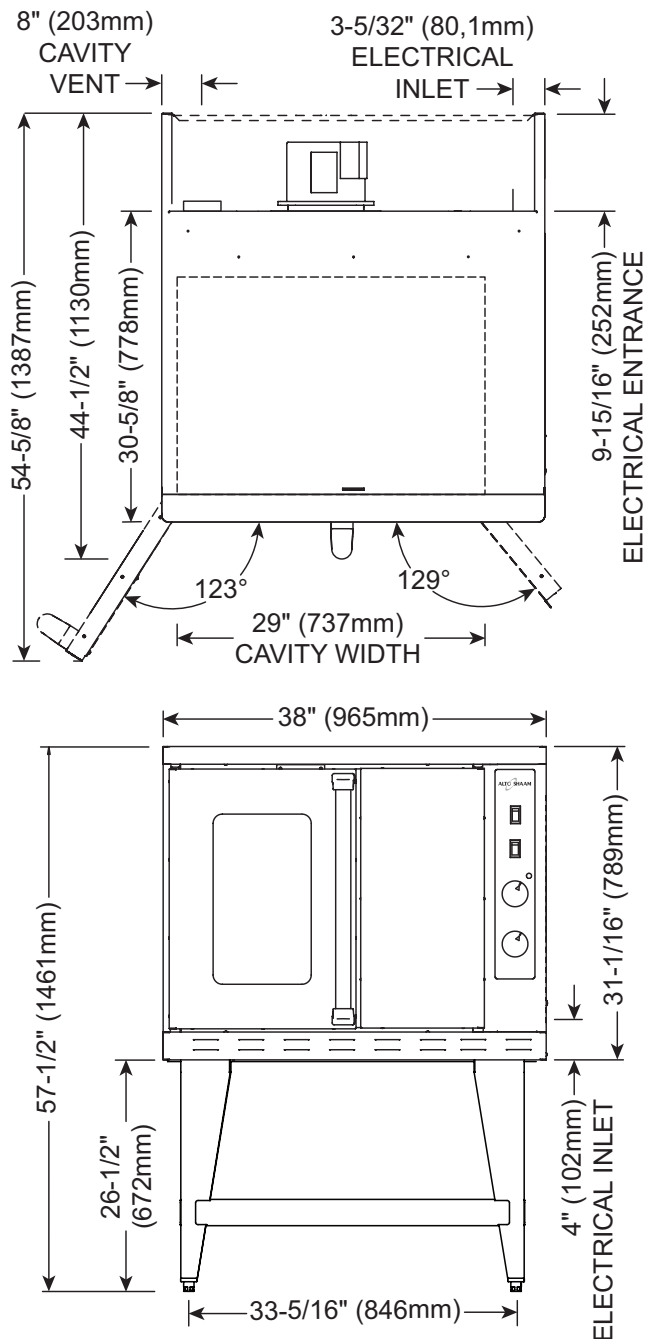

DIMENSIONS (H X W X D)

EXTERIOR: 57-1/2" x 38" x 44-1/2" (1461mm x 965mm x 1130mm)

INTERIOR: 24" x 29-1/8" x 25" (610mm x 740mm x 635mm)

ELECTRICAL - ASC-4E

VOLTAGE	PHASE	CYCLE/HZ	AWG	AMPS	kW
208	1	60	6	50.0	10.4
240	1	60	6	43.3	10.4
208	3	60	8	28.8	10.4
240	3	60	8	25.0	10.4
440-480	3	60	12	13.6	10.4
220	1	50	6	40.0	8.7

NO CORD AND PLUG

MINIMUM CLEARANCE REQUIREMENTS

SIDES, LEFT AND RIGHT	2" (51mm)
BACK SIDE	0" (0mm)
FROM GREASE PRODUCING EQUIPMENT	6" (152mm)
RECOMMENDED SERVICE ACCESS RIGHT SIDE	20" (508mm)

INSTALLATION REQUIREMENTS

- This appliance must be installed level and must not be installed in any area where it may be affected by steam, grease, dripping water, high temperatures, or any other severely adverse conditions.
- Mobile appliances must be secured to the building structure by means of a restraining device (NOT FACTORY SUPPLIED).
- Hood installation is recommended (CHECK LOCAL CODES).

PRODUCT/PAN CAPACITY

72 lb (33 kg) maximum • 45 qts (43 liters)

Twelve (12): 18" x 26" x 1" full-size sheet pans

6 chrome plated wire shelves with 2 removable side racks and 12 shelf positions spaced at 1-3/4" (43mm)

WEIGHT

NET: 393 lb (178kg)

SHIP: 535 lb (243 kg)

CRATED DIMENSIONS: 53" L x 45" W x 49" H
(1346mm x 1143mm x 1245mm)

MINIMUM ENTRY CLEARANCE: 31-1/2" (800mm) UNCRATED, WITHOUT LEGS

ACCESSORIES

<input type="checkbox"/> REAR ENCLOSURE PANEL, STAINLESS STEEL 5005876	STAND, STAINLESS STEEL
<input type="checkbox"/> SHELF, OVEN RACK INTERCHANGEABLE WITH COOLING RACK SH-26795	<input type="checkbox"/> Mobile, with Cooling Racks & Casters, 38" H (965mm) 5003786
STACKING HARDWARE SEE INDIVIDUAL STACKING COMBINATION SPECIFICATION SHEETS	<input type="checkbox"/> Stationary, with Cooling Racks & Bullet Feet 5003489
	<input type="checkbox"/> Stationary, with Cooling Racks & Seismic Feet 5003787 34-1/4" (870mm) min. • 35-1/2" (902mm) max. H (FEET ARE ADJUSTABLE)



W164 N9221 Water Street • P.O. Box 450 • Menomonee Falls, Wisconsin 53052-0450 • U.S.A.

PHONE: 262.251.3800 800.558.8744 U.S.A./CANADA FAX: 262.251.7067 800.329.8744 U.S.A. ONLY

www.alto-shaam.com

