

## Food Bars

### Floor

Models 6FBR - 6 ft. (182 cm), 5FBR - 5 ft. (162 cm)  
4FBR - 4 ft. (130 cm)

#### Features & Benefits



- Versatility, style and durability for self-service breakfast, lunch or dinner. Accommodates GN 1/1 Full or Fractional Size Food Pans up to 6" (15 cm) deep with Divider Bars.
- Double-wall polyethylene construction provides extra strength, durability and reliability. Scratch-resistant textured exterior. Simple to clean - just wipe off.
- Thick foamed-in-place polyurethane insulation maintains food temperatures and holds ice cold for hours. Provides added structural strength.
- NSF listed threaded faucet drain with a standard hose hook-up provides quick draining and cleaning.
- Four each 5" (12,7 cm) swivel casters w/ brakes ensure easy maneuvering.
- Standard accessories include protective Sneeze Guard panel made from NSF listed material.
- Optional accessories include Tray Rails, End Tables, Divider Bars, Crock Holder, and Salad Bowl Holders.
- Non-electrical.
- Easy to assemble.
- Available in 15 colors.

Item No. \_\_\_\_\_

Specifier Identification No. \_\_\_\_\_

Model No. \_\_\_\_\_

Quantity \_\_\_\_\_



**5FBR**  
(Shown with optional End Tables and Tray Rail)



Optional End Table FBRTBL

### Set Up Guide for Floor Model Food Bars

#### Salad Bowls and Crock

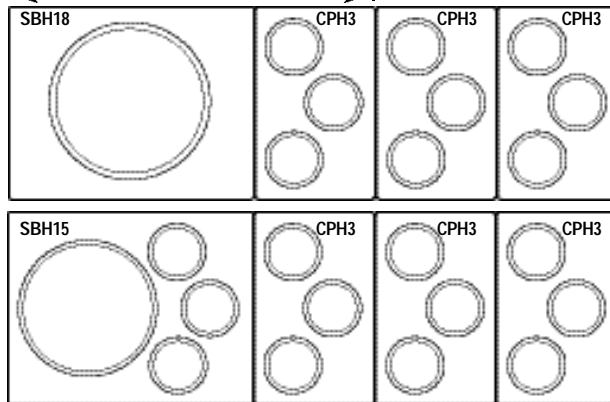
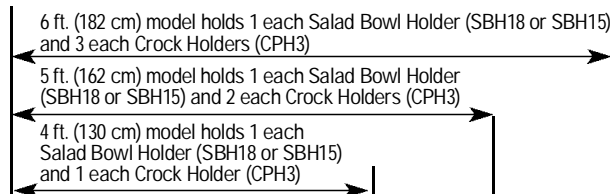

SBH18 - Holds 1 each 18" (45,7 cm) Salad Bowl  
SBH15 - Holds 1 each 15" (38 cm) Salad Bowl & 3 each 1.5 qt. (1,4 L) or 2.7 qt. (2, 4 L) Crock  
CPH3 - Holds 3 each 1.5 qt. (1,4 L) or 2.7 qt. (2, 4 L) Crock

#### Food Pans

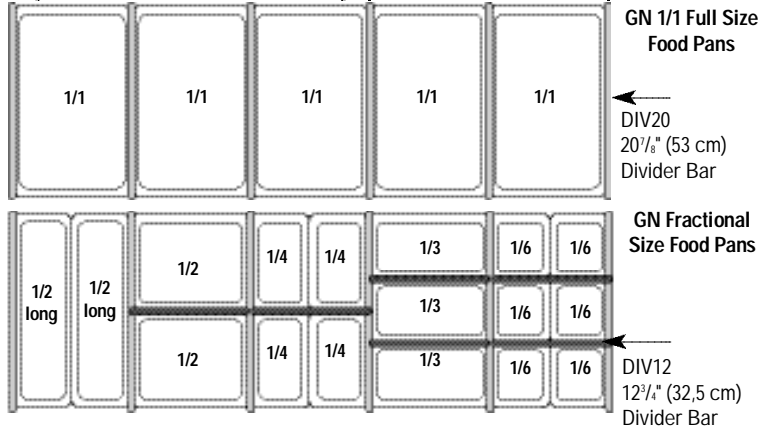
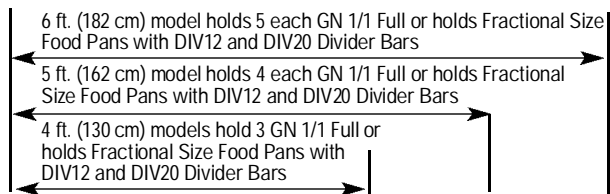

### Approvals



# Food Bars

## Floor

Models 6FBR - 6 ft. (182 cm), 5FBR - 5 ft. (162 cm)  
4FBR - 4 ft. (130 cm)

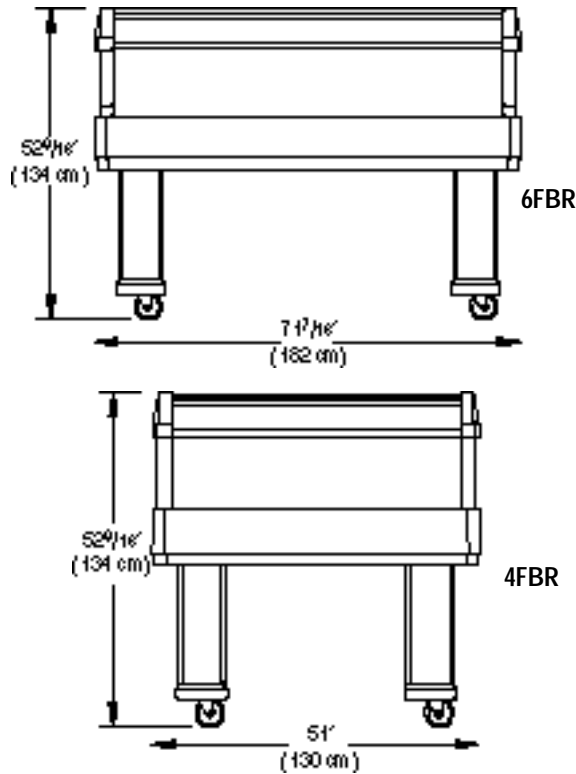

Item No. \_\_\_\_\_

Specifier Identification No. \_\_\_\_\_

Model No. \_\_\_\_\_

Quantity \_\_\_\_\_

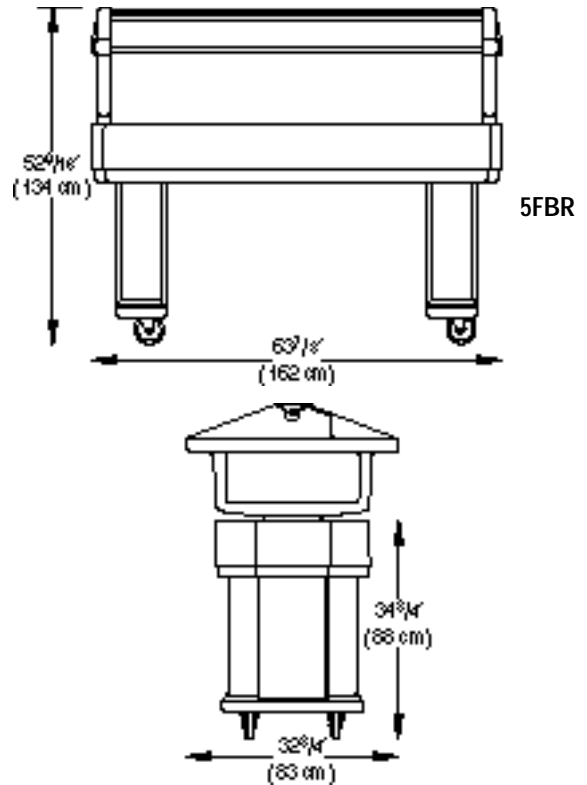

## Specifications

Dimension Tolerance: +/- 1/16" (0,64 cm)

Code	Description	GN 1/1 Full Size Food Pan Capacity	Exterior Dimensions L x W x H	Case lbs./cube Kg/m <sup>3</sup>
6FBR	6 ft. (182 cm) Floor Model Food Bar	5	71 1/16" x 32 3/4" x 52 9/16" (182 x 85 x 134 cm)	148 (28.10) 67 (0,79)
5FBR	5 ft. (162 cm) Floor Model Food Bar	4	63 1/8" x 32 3/4" x 52 9/16" (162 x 85 x 134 cm)	134 (25.82) 61 (0,72)
4UBR	4 ft. (130 cm) Floor Model Food Bar	3	51" x 32 3/4" x 52 9/16" (130 x 85 x 134 cm)	126 (25.82) 57 (0,72)

## Optional Accessories

- Tray Rails**
- FBR6R (6 ft.) (182 cm)
  - FBR5R (5 ft.) (162 cm)
  - FBR4R (4 ft.) (130 cm)
- End Tables**
- FBRTBL
- 3-Crock Holder**
- CPH3 (holds 1.5 qt. (1,4 L) and 2.7 qt. (2,4 L) crocks)
- Salad Bowl Holders**
- SBH15 (holds one 15" (38 cm) bowl, 3 crocks)
  - SBH18 (holds one 18" (46 cm) bowl)
- Divider Bars**
- DIV12  DIV20

## Standard Colors

- Black (110)
- Coffee Beige (157)
- Navy Blue (186)
- Green (519)
- Granite Green (192)
- Slate Blue (401)
- Dark Brown (131)
- Dusty Rose (400)
- Hot Red (158)
- Granite Red (193)
- Brick Red (402)
- Cold Blue (159)
- Gray (180)
- Granite Gray (191)
- Granite Sand (194)

### Divider Bar:

- White (148)
- Clear (035)

### Crock Holder and Salad Bowl Holder:

- White (148)

## Architect Specs

The non-electrical portable foodservice Food Bar shall be a Floor Model Food Bar, Model..., manufactured by Cambro Mfg. Co., Huntington Beach, CA 92648 U.S.A. It shall be made of double-wall polyethylene and foam-injected polyurethane insulation. It shall have 4 each, 5" (12,7 cm) swivel casters with brakes. It shall hold optional accessories such as the Cambro Salad Bowl Holders (SBH18 and SBH15) and Crock Holder (CPH3) or a selection of GN Full or Fractional Size Food Pans with Divider Bars. The depth of the interior food wells shall be 6 1/2" (16,5 cm). It shall be available with optional end tables and

side tray rails. It shall include a sneeze guard and protective end panels. It shall have an NSF Listed threaded faucet drain with a standard hose hook up. It shall be available in 15 colors.

## Approvals

