

## CamKiosk® Hand Sink Cart

Model KSC402

Item No. \_\_\_\_\_

Specifier Identification No. \_\_\_\_\_

Model No. \_\_\_\_\_

Quantity \_\_\_\_\_



### Features & Benefits

- Stands alone for hand washing. Also attaches to the CamKiosk Cart or CamKiosk Work Station with the optional Connector Bridge to help expand menu options.
- Double-wall, high-density, polyethylene construction is impact resistant and will not dent, crack, bubble, chip or break. Can be wiped or steam cleaned.
- Polyurethane foam core provides added strength and durability.
- Two (2) compartment stainless steel sink is ETL listed. Lead-free faucet runs cold water and hot water up to 140°F (60°C). Faucet is NSF-61 listed.
- Two (2) white 5 gallon (18,9 L) fresh water tanks and two (2) gray 7.5 gallon (28,4 L) gray water tanks provide approximately 70 hand washings. Tanks are easy to insert and remove for emptying and refilling.
- Hot water heater has a 2.5 gallon (9,5 L) capacity and heats water in 10 minutes. 110 volt outlet required.
- Water pump is NSF listed & UL approved. Hot water heater is UL approved. Each draw a maximum of 0.7 amps and 11.25 amps respectively. Hand sink cart electrical system runs on average 10 amps.
- Molded-in handles on both sides make the cart easy to transport.
- Four (4) 6" (15,2 cm) casters, two (2) fixed, two (2) swivel with brakes allow for easy transport across a lobby floor, lunchroom or campus grounds.
- Paper towel roll holder and soap dispenser included.
- Electrical 110 volt.
- Some assembly required.
- Available in five (5) solid colors and one (1) color combination.



KSC402



Two (2) Compartment Stainless Steel Sink



Tanks and Hot Water Heater

### Approvals



Water Pump and Water Heater only



Water Pump only



# CamKiosk® Hand Sink Cart

Model KSC402

Item No. \_\_\_\_\_

Specifier Identification No. \_\_\_\_\_

Model No. \_\_\_\_\_

Quantity \_\_\_\_\_

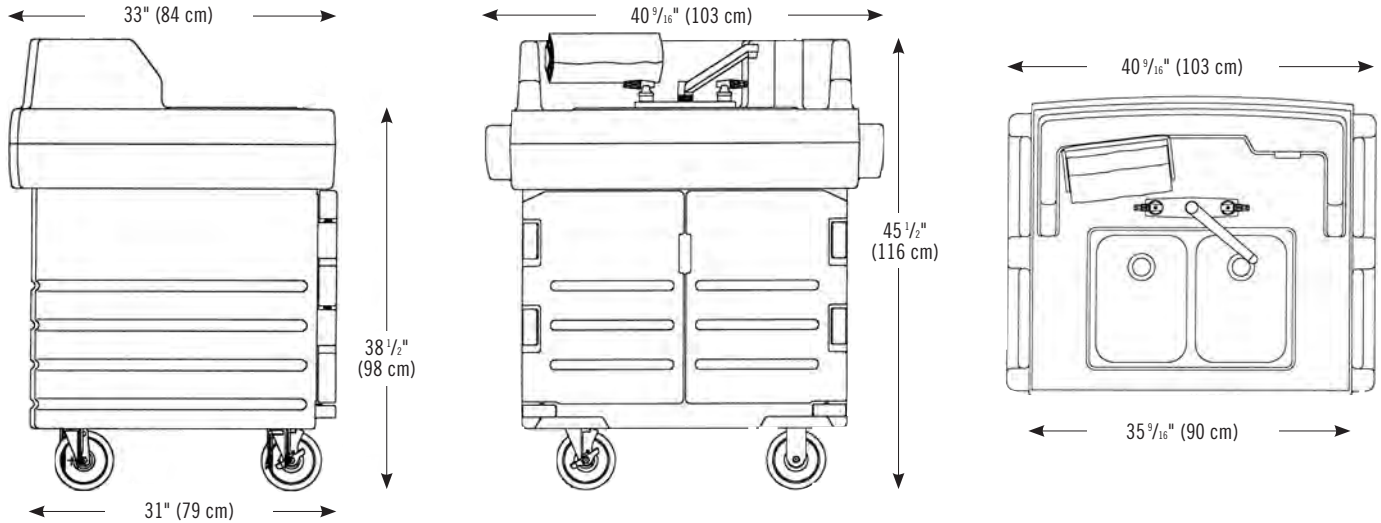

## Specifications

Dimension Tolerance: +/- 1/4" (0,64 cm)

Code	Description	Overall Dimensions W x D x H	Case lbs./cube Kg/m <sup>3</sup>
Domestic (110 volt) KSC402	2 Compartment Hand Sink Cart	40 9/16" x 33" x 45 1/2" (103 x 84 x 116 cm)	224 (39.5) 101,6 (1.1)

## Optional Accessories

- Connector Bridge with Front Panel\*  KMC24
- Bridge\*\* 25" x 34" x 8 1/2" (63,5 x 86,4 x 22,4 cm)
- Front Panel 28 1/2" x 24 1/4" x 3" (72,4 x 61,6 x 7,6 cm)

\*Bridge and front panel can be purchased separately as replacement parts.

\*\*Can be used without front panel.

## Standard Colors

- Granite Gray (191)
- Navy Blue (186)
- Kentucky Green (519)
- Granite Green (192)
- Hot Red (158)
- Black Base with Granite Gray Top & Doors (426)

## Architect Specs

The portable, electrical Hand Sink Cart shall be a CamKiosk Electrical Hand Sink Cart, manufactured by Cambro Mfg. Co., Huntington Beach, CA 92647 U.S.A. It shall be a Cambro Model KSC402. It shall be made of polyethylene with a polyurethane core. It shall have molded-in handles, four (4) ea. 6" (15,2 cm) casters, two (2) fixed, two (2) swivel with brake. It shall have a two (2) compartment stainless steel sink with a lead free faucet that runs cold and hot water up to 140°F (60°C). It shall have two (2) each 5 gallon (18,9 L) fresh water tanks, two (2) each 7.5 gallon (24,4 L) gray water tanks and one (1) 2.5 gallon (9,5 L) hot water heater, 110 volt, UL Approved. The water pump shall be UL Approved and ETL and NSF listed. Water pump and water heater shall draw a maximum of 0.7 amps and 11.25 amps respectively. Hand Sink Cart electrical system shall run on average 10 amps. It shall include a paper towel holder and soap dispenser and shall be available in six (6) color options.

## Approvals



Water Pump and Water Heater only



Water Pump only



**CAMBRO**  
TRUSTED FOR GENERATIONS™

© Cambro Manufacturing Company 5801 Skylab Road, Huntington Beach, California 92647-2056-U.S.A.  
Telephone 714 848 1555 Toll Free 800 854 7631 Customer Service 800 833 3003