



V150PL Food Mixer - 150 Quart Mixer

Project	Item Number	Quantity
-----	-----	-----



Variable speed V-belt transmission
 Powerful 5 hp motor for heavy duty
 purpose



ETL listed
 Conforms to UL Std 763
 Certified to CSA Std C22.2 No.195



Standard Features

- Powerful 5 hp motor for heavy duty use
- Variable Speed Drive with wide agitator speed range from 50 rpm to 250 rpm
- Power Bowl Lift
- Top cover, planetary cover and bayonet shaft in stainless steel. Durable powder coated finish used on those surfaces not constructed of stainless steel
- Rubber feet.
- Stainless Steel bowl screen
- Front mounted controls with 15-minute timer with HOLD feature
- No bowl adaptors required for the down-size bowls
- High torque transmission. Grease lubricated, anti friction ball bearings.
- Permanently lubricated planetary head
- Locking pin on tools instead of shaft.
- Safety cut-switch automatically turns the mixer off if bowl screen is opened
- Overload protection and no voltage release
- Bowl truck with double wheel
- 6 feet cord
- ETL and NSF listed

Optional Features

- Mixer in Stainless Steel
- Marine version USPHS
- Prison package
- Mark IV Control System

Accessories:

- 150 quart bowl - stainless steel
- Dough hook - stainless steel and double pin
- Wire whip - stainless steel and double pin
- Center reinforced whip with double pin
- Aluminum flat beater with double pin
- Bowl scraper
- Stainless steel wing whip with double pin
- Powder mixer - stainless steel and double pin
- 83 quart bowl and accessories
- Bowl screen ingredient chute
- Bowl truck
- Tool rack, 60- 150 Qt mixers

Warranty:

Two year parts and labor limited warranty

Approved By: _____ Date _____

 **Varimixer**
 www.varimixerusa.com

14240 South Lakes Drive
 Charlotte, NC 28273
 Phone: 800-222-1138
 Fax: 704-583-1703
 mixer@varimixerusa.com



V150PL Food Mixer - 150 Quart Mixer

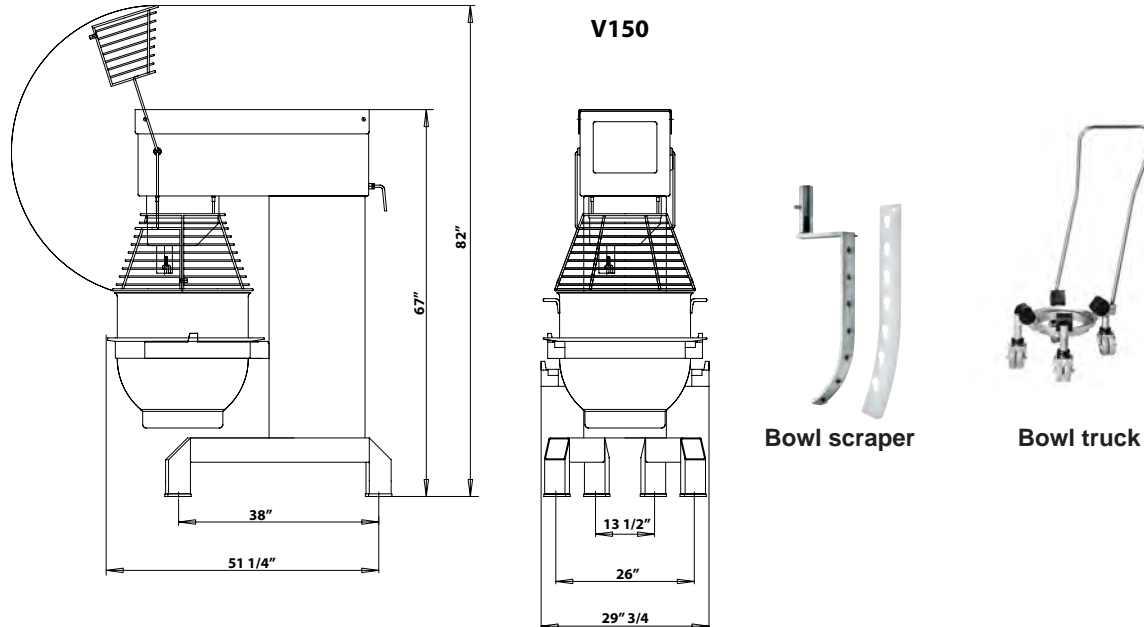

Specifications

Model No.	Capacity	Overall size			Net. weight
		Height H	Width W	Length L	
V150PL	Large bowl 150 qt. Small bowl 83 qt.	67" (170.18 cm)	29 3/4" (75.56 cm)	51 1/4" (130.17 cm)	1147 lbs. (520.27 kg)

Shipping information

Class	CU. FT.	Dimensions			Weight
		Height	Width	Length	
85	84	78" (198.12 cm)	37" (93.98cm)	55" (139.7cm)	1397 lbs.(633.67 kg)

Cord & Plug	Attached 6 foot flexible 3-wire cord		
Electrical Data for Motor	Motor	Volts	Amp
Standard	5 HP	208/60/3	16
Optional	5 HP	480/60/3	7
Optional (contact us)	400V / 50Hz / 3 Ph lead time 6 to 8 weeks		
On the nominal motor voltage, + or - 10% tolerance is allowed.			
Mixing Speed			
Agitator Speed	Min	Max	
	50	250	
Mixer in Stainless Steel Marine version USPHS: Stainless steel execution, stainless steel bowl arms, water cover at air ventilation, slotted free screws, full welded stainless steel knees. Prison package MK IV Control Panel: Programmable electronic panel			

Capacity Chart

Mashed Potatoes	Whip or Beater	110 lbs.
Whipped Cream	Whip	32 Qts.
Muffins	Beater	195 lbs.
Layer Cake	Beater	175 lbs.
Pancake Batter	Whip or Beater	50 Qts
Cookie Dough	Beater or Hook	160 lbs.
Donuts, Yeast	Hook	170 lbs.
Donuts, Cake	Beater	225 lbs.
Bread Dough (65% AR)	Hook	190 lbs.
Pizza Dough (50% AR)	Hook	175 lbs.

%AR= $\frac{\text{weight of water}}{\text{weight of flour}}$

Batch size and/or speed reduction is required if any of the following conditions exist.

1. High Gluten Flour
2. AR % under 40%
3. Water Temperature under 65 Degrees F.

Varimixer
www.varimixerusa.com

14240 South Lakes Drive
Charlotte, NC 28273
Phone: 800-222-1138
Fax: 704-583-1703
mixer@varimixerusa.com