



# HEAVY DUTY PORTABLE BAR WITH STAINLESS STEEL INTERIOR

## FEATURES:

- All Stainless Steel Interior
- 19" x 13-1/2" x 11" insulated ice bin. Complete with drain & shut-off valve
- Full perimeter bumpers
- 4 - 5" Heavy Duty Swivel Casters, 2 with brakes
- AMD Series** - Includes 2 hinged doors with locks

## MATERIAL:

- TOP & FRONT:** Mica Laminate, black finish
- UNIT:** Stainless Steel work top, back, sides & bottom
- WORK AREA:** Stainless Steel
- CASTERS:** Rubber
- SPEED RAILS:** Stainless Steel

**ALL STAINLESS STEEL INTERIOR! Upgrade for Stainless Steel Front Available.**

Item #:	_____	Qty #:	_____
Model #:	_____		
Project #:	_____		

**DESIGNED FOR HEAVY-DUTY USE**

**Custom Colors Available!**  
(Exterior Only. See below for details)



AMS-5B Front Shown



AMS-5B Rear Shown

Model #	Size L x W x H	Storage Cabinet Dim.	Bar Top Width	Weight	Cubic Feet
AMS-5B	61" x 23" x 47"	58" x 21" x 18.5"	12"	315	50
AMS-6B*	74" x 23" x 47"	23.5" x 21" x 27.5"	12"	370	60
UNITS WITH STAINLESS STEEL DOORS					
AMD-5B*	61" x 23" x 47"	58" x 21" x 18.5"	12"	340	50
AMD-6B*	74" x 23" x 47"	23.5" x 21" x 27.5"	12"	400	60

\*Units Include Center Stainless Steel Panel For Extra Support



AMD-6B Rear Shown

### Upgrade for Cold Plates Available

Add the suffix, **-7** to the model number.  
(Factory Install Only. Add 35 lbs. to weight)

## Available Accessories

Custom Mica Colors - **Model SU-81**  
Custom colors include exterior finishes only (Bar front, doors-if applicable and bar top. All interiors are stainless steel.)



**Customer Service Available To Assist You 1-800-645-3166 8:30 am - 8:00 pm E.S.T.**

For Orders & Customer Service:  
Email: customer@advancetabco.com or Fax: 631-242-6900

For Smart Fabrication™ Quotes:  
Email: smartfab@advancetabco.com or Fax: 631-586-2933

# DIMENSIONS and SPECIFICATIONS

TOL ± .125"

ALL DIMENSIONS ARE TYPICAL

## AMS SERIES

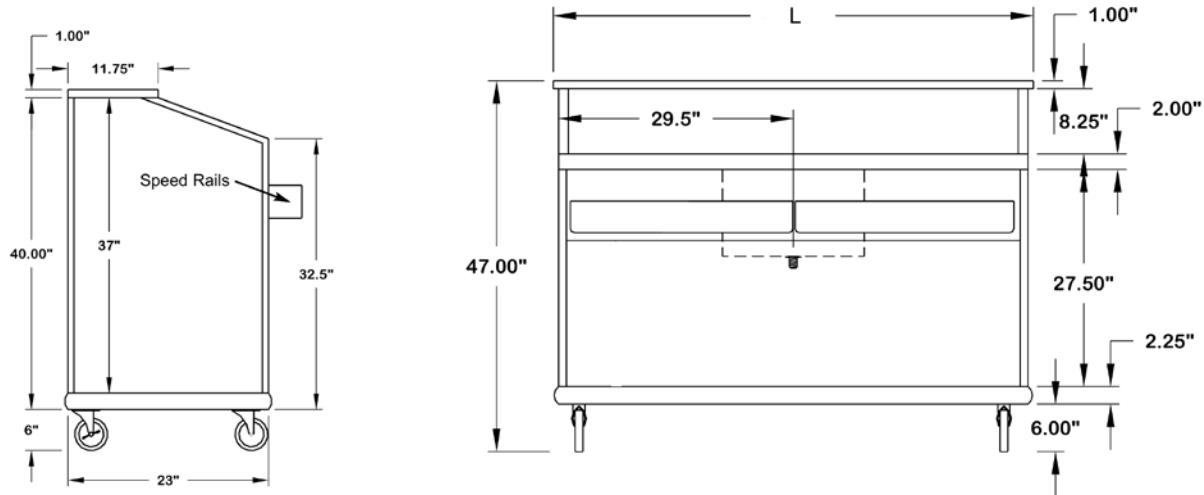

\*AMS-6B Includes a Center Panel

## AMD SERIES

