



SMARTSTEAM100 BOILERLESS STEAMER

MODEL SSB-10GF

Steamer shall be a Groen Model SSB-10GF SmartSteam100™ stainless steel, boilerless, convection steamer with a self-contained atmospheric 100,000 BTU/hr gas steam generating reservoir.

CONSTRUCTION: Steamer cavity, cabinet and stand shall be all stainless steel construction, with removable right and left-side panels, providing access to internal components. Steamer shall have no side vents for increased water/spray resistance. Steamer cavity shall accommodate 18 x 26" bake pans. Steamer door shall be all stainless steel with a strong continuous hinge and field-reversible for left or right swing. Door shall be insulated and provided with a one-piece, replaceable seal. Easy-open door handle and latch shall provide positive lock and seal when door is pushed or slammed shut. A hidden magnetic door switch shall cut power to blower fan and shut down power to the steam generating reservoir when the door is opened. Pan support racks shall be stainless steel and removable for easy cleaning. A stainless steel condensate collection tray shall be positioned under the cavity door.

FINISH: Cabinet exterior, including door, shall be a #3 uniform finish. Cavity interior shall be polished stainless steel. Control panel face plate shall be smudge-resistant polyester film, ensuring maximum ease in cleaning and maintenance of an attractive appearance.

CSA LISTING: Steamer shall be CSA (formerly CGA) design certified.

SANITATION: Steamer shall be designed and manufactured to meet NSF requirements and all known health codes. Steamer shall be NSF listed.

CONTROLS: Steamer controls shall include an on-off rocker switch; electronic timer, with continuous steam, timed steam and stop buttons; READY light which indicates when cavity is warm and ready for steaming.

PERFORMANCE FEATURES: Steamer cavity shall have a powerful, side-mounted blower to increase steam velocity and provide efficient steam distribution throughout the cavity and between loaded pans. Steam generator shall deliver 10,600 BTU/hr of power input per 2-1/2" deep steam pan. Steamer shall have a steam lid positioned over the steam generating reservoir to ensure that adding/removing food does not lower the cavity

or water temperature. Heat up time to READY shall typically be 15 minutes or less. Cavity is kept warm and ready for instant steam between loads. No cavity warm up required after READY light comes on.

ATMOSPHERIC STEAM GENERATING RESERVOIR: Steamer shall have a gas-heated steam generating reservoir to provide atmospheric steam to the cavity at a temperature of approximately 212° F. The high-efficiency steam generating reservoir shall have water sensors. Gas heater shall have infrared burners with a firing rate of 100,000 BTU/hr. Acidic products and other commercial chemicals shall not be used to clean the steamer. A daily wipe down of the steamer cavity, steam lid and water probes is sufficient to maintain optimal operation of the steamer. However, Groen Descaler or approved equal may be required.

PAN CAPACITY:

Pan Size/ Type	Total
12 x 20 x 1"	20
12 x 20 x2 1/2"	10
12 x 20 x 4"	6
13 x 18 bake pan	20
18 x 26 bake pan	10

INSTALLATION: Steamer shall require natural or propane (specify) gas service via a 1/2" NPT gas supply line, or approved equivalent. Steamer shall be connected to a 3/4" NH cold water supply line and a 2" free venting drain. Steamer shall require 115 Volt, single-phase electrical service.

WATER SUPPLY REQUIREMENTS:

Steamer must be connected to an on-site water supply. Water supply at 30 to 60 PSIG with flow at .75 - 1.5 GPM per cavity.

ORIGIN OF MANUFACTURE: Designed and manufactured in the United States.

PROJECT NAME:

LOCATION:

ITEM NO:

QTY:

MODEL NO:

AIA NO:

SIS NO:

SHORT FORM: 10-Pan Boilerless Convection Steamer, stand-mounted, stainless steel, self-contained, gas heated. (Model SSB-10EF shown)



OPTIONS/ACCESSORIES:

- Factory Stacking Kit
- Pan Rack Kit (for support stand)
- Flanged Foot Kit (for support stand)
- Caster Kit (for support stand)
- Heat Shield Kits
- High Altitude Kit (above 2000', specify)

SmartSteam100
146575F Revised 08/13



SERVICE CONNECTIONS & NOTES:

P/N 146344 REV F

- ① DRAIN CONNECTION: 2" [51] HOSE TYPE (DRAIN FREE VENTING). DO NOT CONNECT DIRECTLY TO DRAIN. ALLOW 2" AIR GAP
- ② GAS CONNECTION: 3/4" NPT MINIMUM GAS SYSTEM MUST DELIVER 100,000 BTU'S AT UNIT
- ③ WATER SUPPLY: 3/4" MALE HOSE CONNECTION 30 TO 60 PSIG WITH A FLOW RATE OF 0.75-1.50 GPM. PRESSURE REGULATION IS REQ'D FOR WATER PRESSURE OVER 60 PSI. DO NOT USE TREATED WATER.
- ④ ELECTRICAL CONNECTION: 120VAC, 60Hz, 15AMP CONDUIT SIZE: 13/16" HOLE
- ⑤ MINIMUM REAR AND SIDE CLEARANCES: EACH SIDE = 2" [50.8] REAR = 6" [152.4]
- ⑥ DIMENSIONS IN BRACKETS [] ARE MM.
- ⑦ IF THE FLOOR DRAIN ONLY SERVICES THIS STEAMER, THEN THE DRAIN MAY BE LOCATED WITHIN THE STEAM FREE ZONE. STEAM FREE ZONE MUST BE OBSERVED IF OTHER APPLIANCES CAUSE STEAM AT THE FLOOR DRAIN.
- ⑧ DO NOT INSTALL STEAMER DIRECTLY ABOVE STEAM VENTING FLOOR DRAINS
- ⑨ STEAM EXHAUST

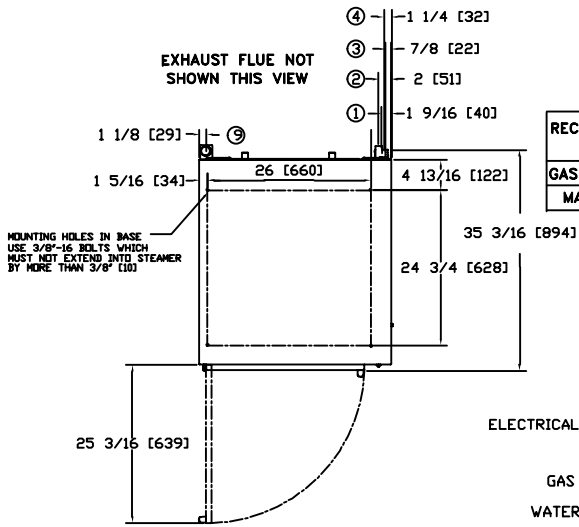

EACH COMPARTMENT	NATURAL GAS	PROPANE GAS
RECOMMENDED INCOMING GAS FEED RATE	5" WC (1.2 KPa) MIN.	12" WC (3 KPa) MIN.
	14" WC (3.5 KPa) MAX.	14" WC (3.5 KPa) MAX.
GAS OPERATING PRESSURE	4.25" W.C.	10.5" W.C.
MAX. INPUT BTU/HR	100,000	100,000

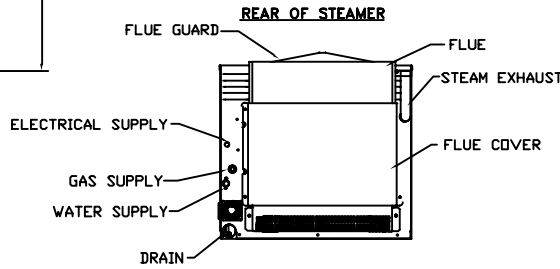

STEAM FREE ZONE

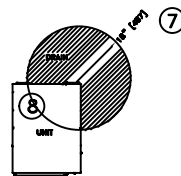

FRONT OF STEAMER

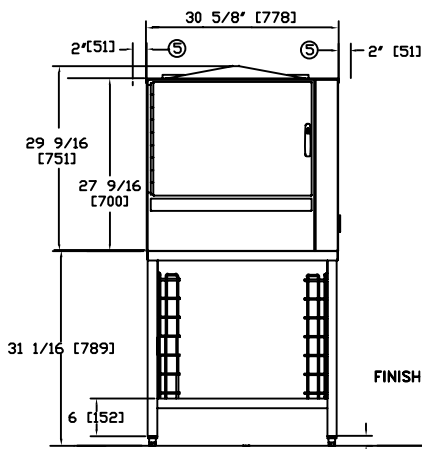

FRONT VIEW

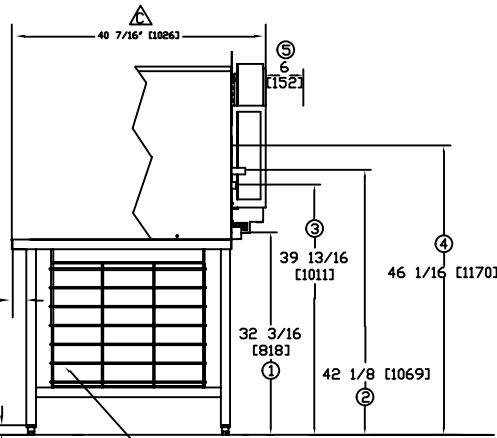

SIDE VIEW

FINISHED FLOOR

OPTIONAL RACKS