



## Model 35C+ & 45C+ Economy Tube Fired Gas Fryers



### STANDARD ACCESSORIES

- Cabinet - stainless steel front, door
- Galvanized sides and back
- Tank - mild steel with stainless front
- Built-in integrated flue deflector
- Two nickel plated oblong, wire mesh baskets
- One nickel-plated tube rack
- One drain extension
- One drain line clean-out rod
- Removable basket hanger for easy cleaning
- 6" (15.2 cm) adjustable legs

### AVAILABLE OPTIONS & ACCESSORIES

- Triple baskets
- Covers
- Fryer cleaner
- Casters

Project \_\_\_\_\_

Item No. \_\_\_\_\_

Quantity \_\_\_\_\_

### STANDARD SPECIFICATIONS

#### CONSTRUCTION

- Welded tank with an extra smooth peened finish ensures easy cleaning.
- Long-lasting, high-temperature alloy stainless steel heat baffles are mounted in the heat exchanger tubes to provide maximum heating and combustion efficiency.
- Standing pilot light design provides a ready flame when heat is required.
- Cabinet front and door are constructed of stainless steel with galvanized sides and back.

#### CONTROLS

- Thermostat maintains selected temperature automatically between 200°F (93°C) and 400°F (190°C-CE).
- Integrated gas control valve acts as a manual and pilot valve, automatic pilot valve, gas filter, pressure regulator, and automatic main valve.
- Gas control valve prevents gas flow to the main burner until pilot is established and shuts off all gas flow automatically if the pilot flame goes out.
- Temperature limit switch safely shuts off all gas flow if the fryer temperature exceeds the upper limit.

#### OPERATIONS

- Front 1-1/4" (3.2 cm) NPT drain for quick draining.
- Standing pilot and thermostat maintain temperature automatically at the selected temperature (between 200°F (93°C) and 400°F (190°C-CE)).

Model 35C+ & 45C+ Economy Tube Fired Gas Fryers



(Model 35C+ only)

Pitco Frialator, Inc., P.O. Box 501, Concord, NH 03302-0501 • 509 Route 3A, Bow NH 03304, USA  
(603) 225-6684 • Fax (603) 225-8472 • [www.pitco.com](http://www.pitco.com)



L10-144 Rev 8 (04/08)

## Model 35C+ & 45C+ Economy Tube Fired Gas Fryers

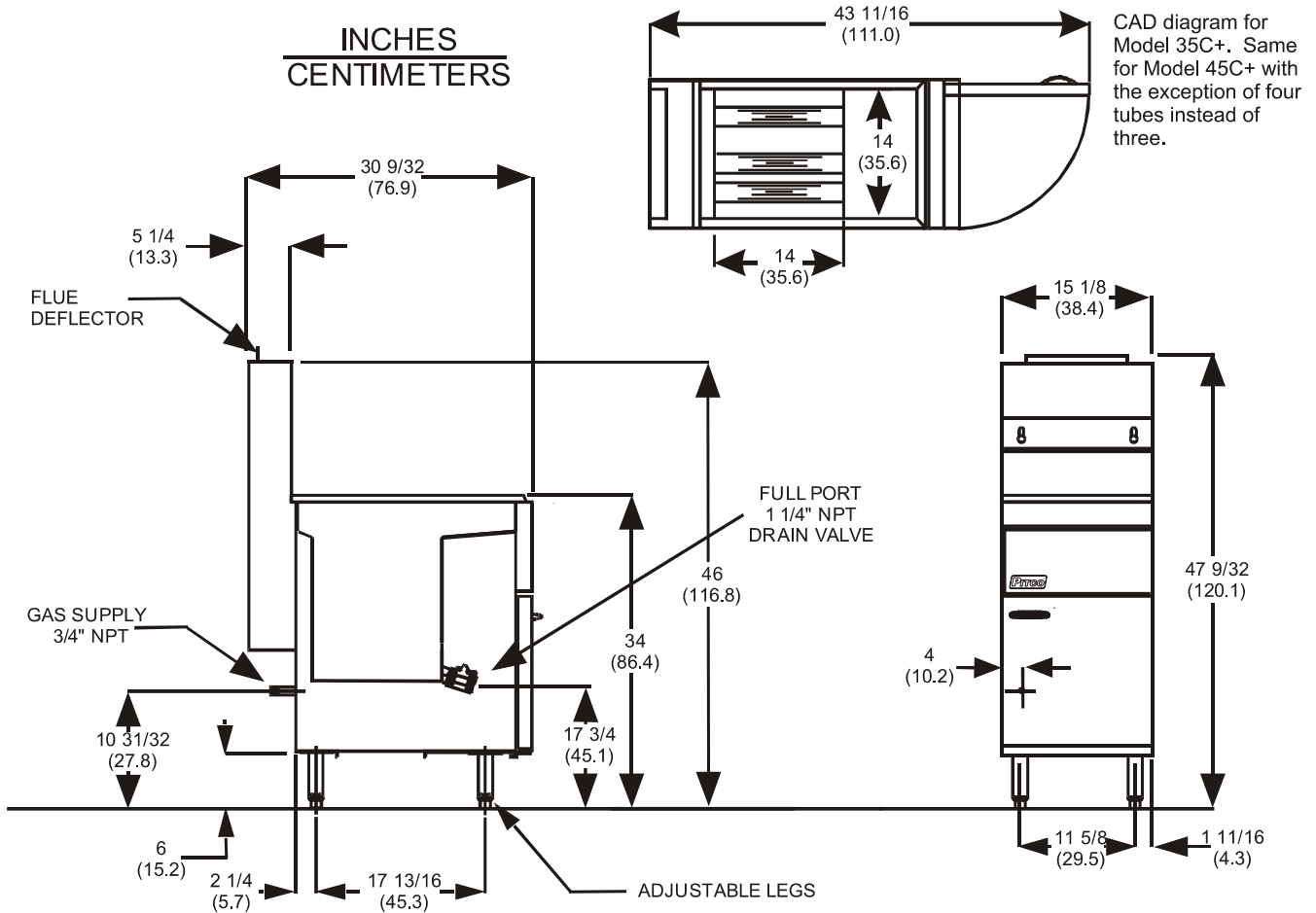

ELECTRICAL		OIL CAPACITY
<b>Description</b>	Voltage/Phase/HZ	
	120/1/60	24/1/50
	AMPS/EA	AMPS/EA
No electrical options available.		<b>SHIPPING INFORMATION</b> 161 pounds (73 KG) / 17.0 cubic feet (0.48 cubic meters) (Model 35C+) 181 pounds (82.1 KG) / 17.0 cubic feet (0.481 cubic meters) (Model 45C+)
GAS CONSUMPTION		PERFORMANCE CHARACTERISTICS
90,000 BTU's/Hour (22,680 Kcal) – Model 35C+ 122,000 BTU's/Hour (30,744 Kcal) – Model 45C+ Available in Natural or Propane Gas. For other Fuel types, contact your Dealer/Distributor.		Cooks 63 lbs (28.6 KG) of fries per hour – Model 35C+ Cooks 85 lbs (38.6 KG) of fries per hour – Model 45C+ Frying area is 14" x 14" (35.6 cm x 35.6 cm)
SHORT FORM SPECIFICATION		
Provide Pitco Model 35C+, or 45C+ tube-fired gas fryer. Fryer shall have an atmosphere burner system combined with three stainless steel heat tubes (Model 45C+ has four tubes) utilizing high temperature alloy stainless steel baffles. Fryer shall have a deep cool zone; minimum 20% of total oil capacity. Fryer cooking area shall be 14" x 14" (35.6 cm x 35.6 cm) with a cooking depth of 2 3/4" (7.00 cm). Model 45C+ has cooking depth of 4" (10.16 cm). Heat transfer area shall be a minimum of 588 square inches (3,794 sq cm) for 35C+. Heat transfer for Model 45C+ shall be a minimum of 785 square inches (5,058 sq cm). Provide accessories as follows:		
TYPICAL APPLICATION		
Frying a wide variety of foods in a limited amount of space. Frying that requires a medium volume production rate.		



**Pitco Frialator, Inc.**, P.O. Box 501, Concord, NH 03302-0501 • 509 Route 3A, Bow NH 03304, USA

Phone (800) 258-3708 • (603) 225-6684 • Fax (603) 225-8472 • [www.pitco.com](http://www.pitco.com) L10-144 Rev 08 (04/08) Printed in the USA

We reserve the right to change specifications without notice and without incurring any obligation for equipment previously or subsequently sold.