



Model SEH50 High Efficiency Electric Fryer



(Model shown is SEH50/SEH50T with optional Intellifry Computers, casters and filtration system)

STANDARD ACCESSORIES

- Solid State Control
- Baskets (Twin Size)
- Lift off basket hangers
- 9" adjustable legs
- Stainless steel tank, front, door and sides.
- Drain Valve Interlock
- Tank racks
- Clean out rod
- Fryer cleaning brush

AVAILABLE OPTIONS & ACCESSORIES

- Digital controller
- Intellifry computer
- Solid state back-up control*
- Filter drawer system (for 2 or more fryers)
- Filter system heat tape (for use with solid shortening)
- 9" adjustable casters
- Basket lifts**
- Stainless steel back
- Stainless steel tank covers
- Bread and Batter cabinet
- Flush hose
- Filter powder
- Filter paper

* Solid state control equipped with melt cycle and boil-out, and can be used as back-up in combination with the Intellifry or Digital controls.

** Basket lifts to be used in combination with Intellifry or Digital control.

Project _____

Item No. _____

Quantity _____

STANDARD SPECIFICATIONS

CONSTRUCTION

- High production/fast recovery fryer system in any combination of full vat and twin vat fryers with "filter drawer" filtration system. Combinations without filtration, or single fryers also available.
- Welded tank with an extra smooth peened finish ensures easy cleaning.
- Immersion type, sealed construction heating elements with high temperature alloy stainless steel sheath.
- Solstice Electric fryers are designed with a fixed heating element to eliminate oil migration through pivot components. This design creates a safer working environment by keeping the hot elements in the tank where they belong.
- When used with a filtration system, fryers are available in combinations of two or more units.
- Stainless steel front, door, side panels, and splashback.
- Heavy duty 3/16" (.48 cm) door hinge.

CONTROLS

- Solid State controller maintains the fryer temperature between 250°F (122°C) and 380°F (193°C). Solid State controller has built-in melt cycle and boil-out capability.
- Temperature limit switch safely shuts off the fryer if the oil temperature exceeds the upper limit.
- Drain valve interlock switch shuts disables the fryer if the drain is opened preventing accidental fires. The hermetically sealed proximity switch has no moving parts to get contaminated with grease.

OPTIONAL FILTER SYSTEM

(Available on 2 or more units)

- Filter drawer glides on self aligning roller-less guides
- 1-1/4" NPT drain valve for quick draining on both full and twin tanks.
- Easy to remove filter unit for fast cleaning and paper replacement.
- Filter piping integrated into the fryer for no-hassle filtering.
- Extra large 3" drain manifold to prevent clogging.

APPROVALS

- UL Certified
- CUL Certified
- NSF Listed
- ENERGY STAR Qualified



Pitco Frialator, Inc., P.O. Box 501, Concord, NH 03302-0501 • 509 Route 3A, Bow, NH 03304, USA

(603) 225-6684 • FAX (603) 225-8472 • www.pitco.com



L10-160 Rev 0 (05/03)



Model SEH50 High Efficiency Electric Fryer

Model SEH50 High Efficiency Electric Fryer

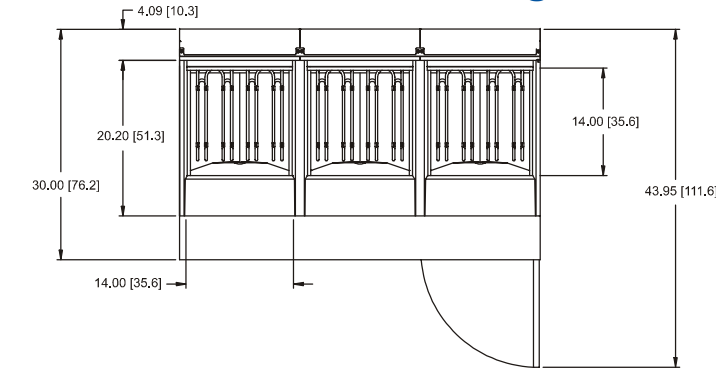

NOTES:

- 440V AND 480V UNITS REQUIRE SEPARATE SINGLE PHASE (115V - 240V) POWER SUPPLY FOR PUMP AND BASKET LIFT OPERATION

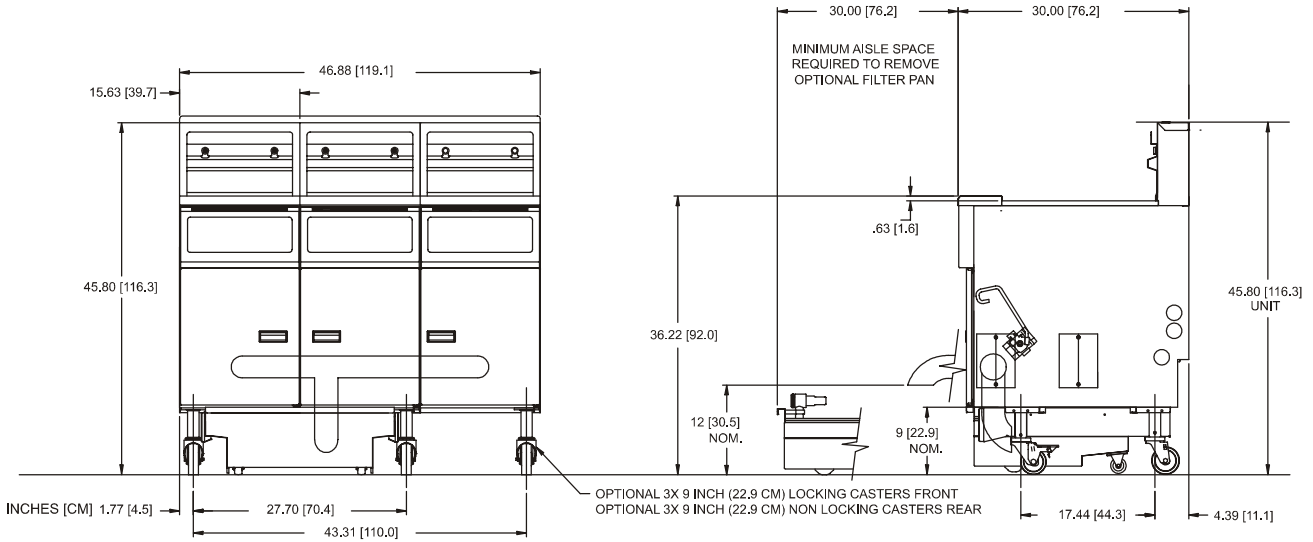

ELECTRICAL				OIL CAPACITY	
Volts/Freq./Phase	AMPS/PH	Volts/Freq./Phase	AMPS/PH	25 pounds (11.3KG) / 3.2 gallons (11liters) per Twin Tank	
208 / 60 / 3	38.9	Fryer Controls:		50 pounds (22.7KG) / 6.1 gallons (23 liters) per Full Tank	
220 / 60 / 3	36.7	120 / 60 / 1PH	0.7	SHIPPING INFORMATION	
240 / 60 / 3	33.7	240 / 50 / 1PH	0.4		
380Y / 220 / 50 / 3	21.3	Filter:		Based on system configuration. Please consult factory.	
400Y / 230 / 50 / 3	20.2	120 / 60 / 1PH	Motor* Heat Tape		
415Y / 240 / 50 / 3	19.5	240 / 50 / 1PH	3.8 0.2		
PERFORMANCE CHARACTERISTICS				ELECTRICAL INPUT	
Twin Tank Frying Area 7" x 14" (17.8 cm x 35.6 cm)				7.0 KW per Twin Tank	
Full Tank Frying Area 14" x 14" (35.6 cm x 35.6 cm)				14.0 KW per Full Tank	
LIMITED WARRANTY					
All Pitco Frialators will be warranted from the date of manufacture against defects in manufacturing or materials as follows:					
Tank		Computers		Other	
10 years parts		2 years parts		1 year parts	
1 year labor		1 year labor		1 year labor	
RETURN POLICY					
No return shipments accepted without prior written approval.					
CANCELLATION FEE					
Orders cancelled or changed after construction has begun, are subject to a 25% charge.					

* All Motors Are Single Phase.



Pitco Frialator, Inc.,

L10-160 Rev 0 (05/03)

P.O. Box 501, Concord, NH 03302-0501 • 509 Route 3A, Bow, NH 03304, USA
(603) 225-6684 • FAX (603) 225-8472 • www.pitco.com

Specifications subject to change without notice

Printed in U.S.A