



DINEK[®]

2019-2020

CATALOG GUIDE

The Dinx Solution.....4-23

Traytops & Accessories24-47

Dishware & Disposables48-55

Decorator Paper Products56-71

Induction Heating Systems72-79

Serving Systems.....80-87

Retherm Systems.....88-95

Serving Counters96-119

Refrigeration.....120-125

Dispensers & Heaters.....126-137

Tray Delivery Carts138-153

Starter Stations & Conveyors.....154-161

Dinnerware & Drinkware ...162-171

Marko172-181

Catering Equipment.....182-187

Kitchen Accessories.....188-193

Storage & Handling.....194-213

Warewashing214-227

Cleaning Tools.....228-241

Transportation & Waste Management242-249

San Jamar.....250-271

Index & Terms272-280



PRODUCT	PAGE	PRODUCT	PAGE
Adjustable Guards	114-116	Utility	247
Air Curtain Refrigerator	122-123	Cashier Stands	107
Allergan Saf-T-Zone System	253	Caution Signs & Cones	241
Antimicrobial Protection Trays	46	Checker Station	79, 156-157
Bar/Service Mat	171	China Dishware	50
Base Heaters	74-77	Cold Food Counter	104-106
Bases		Coldmaster	
Cool Base	36	Coldmaster Solution	208
Induction	36	Coldpans	212
Wax	37	CoolCheck	209
Underliners & Accessories	37	Designer	213
Beverage Servers	184	EZ Access Lids	211
Beverage/Urn Stands	119	Ice Cream Server, Shroud & Lid	213
Blast Chiller/Shock Freezer	124	Standard Food Pans & Lids	210
Bowls	41-42	Whipped Cream & 1 Quart Carton Chiller	209
Brooms	233-234	Condiment Caddies	171, 259
Brushes		Conveyors	158-161
All Purpose Utility	231	Cool Base	36
Basting Brushes	190	Cooling Paddles	257
Cutting Board	230	Counters	
Dual Surface Floor	231	Beverage	119
Floor Drain	236	Carving	106
High Temp Fryer	232	Cashier Stand	107
Oven & Grill	232	Cold Food	104-106, 118
Pastry	190	Frost Top	105
Sparta Atlas Multi-Purpose	230	Hot Food	102-104, 117-118
Bus Boxes	227	Hot/Cold	102-106, 117-118
Carafes	168-169	Laminated Panels	108
Carts		Slim Line	118
Bussing	245	Solid Top	119
Fold 'N Go	244	Specialty Counter Tops	108
Hydration	87	Customs	
Meal Delivery Cart Solutions	140-141	Cutlery Caddies	68, 71
MealtimeXpress Support	85	Menus	70-71
Multi-Use Aluminum Tray Delivery	153	Napkins	64-65, 67-69, 71
Multi-Use Aluminum Tray Delivery Cover	153	Tray Tickets	70-71
Perfect•Serv Ultra Support	95	Traycover Designs	58-67, 71
Service	246	Cut Protection	
Specialty Tray Delivery	150-151	Bag Boa	265
Stainless Steel Utility	246	Bandages	264
Thermal•Aire III	83, 91	Gloves	265
TQ Economy Tray Delivery	148-149	Cutlery Caddies	68-69
TQ Supreme Tray Delivery	142-143	Cutting Boards & Accessories	252-253
TQ Quiet Tray Delivery	144-147	Decorator Traycovers	58-67
Tray Retrieval	82, 148, 150, 152		
TVL Economy Tray Delivery	152		

product listings on next page »

PRODUCT	PAGE	PRODUCT	PAGE
Dishware		Heaters	
China	50	Convection Wax Base	129
Disposable	51, 54-55	Plate	128
Melamine	51, 164-167	Plate/Base	128
Microwavable Disposable	51	Heritage Collection	32-33
Dinex Solutions	4-23	High-Heat Disposable Dishware	51
DineXpress Counters & Accessories	100-108, 110-116	High-Temp Disposable Lids	35
Dinner Napkins	68-69	Ice Cream Freezer	109, 125
Dispensers		Ice Tote & Cart	256
Foil Wrap	255	Induction Bases	36, 74-76
Glove	271	Induction Base Heating	74-77
Napkins	271	Induction Charger Cabinet/Stand	78
Plastic Wrap	255	Insul-Bases	37
Plate	130-132	Insulated Mugs & Bowls	27-28, 30, 33, 35
Soap	270	Insulated Transport	
Towel	269	Beverage Dispenser	184
Tray	133-134	CaterCooler	187
Tray & Silverware	135	Dollies	187
Washrack	137	End Loaders	185-186
Disposable Lids	52-53	Food Carriers	259
Dollies		Pan Carriers	186
Catering	185, 187	Top Loaders	185-186
Washrack	226	Kleen-Pail & Stands	258
Waste Container	249	Knife Stations	254
Domes, Insulated	26-27, 29-30, 32-34	Lids	
Drain Opener Tool	236	Disposable	52-53
Drying & Storage Racks	136	High Temp	35
DuraTherm	36, 74-75, 77	Insulated	28
Dust Pans & Lobby Booms	234	Reusable	30
End Loaders	185-186	Maximizer Portable Bar	170
Fenwick Collection	26-28, 30	Meals On Command II	82
Fiberglass Trays	43-45	Meals On Command II Patient Trays	46, 93
Foods Pans		MealtimeXpress System	84-85
Adapter Bars	201	Support Cart	85
Coldmaster	208	Transfer Dolly	84
DuraPan	201-202	Measurers	
EZ Access Lids	196, 199	Dishers	191
High Heat	196, 200	Commercial Measurers	193
Polycarbonate	196, 198	Color-Coded Measure Misers	192
Smart Lids	197-198, 200	Stainless Steel Measure Misers	191
Universal Lids	196	Menu Forms	70-71
French Whips	193	Microwavable Disposable Food Containers	51
Handles		Milk Cooler	109, 125
Color-Coded Fiberglass	236	Mini Starter Station	79, 156-157
Mop	240	Mobile Heated Cabinet	86
Wood	236	Modular Serving Counter Systems	100-108
Happenings Holiday Collection Traycovers	64-66	Mop Buckets	241
		Mopping Signs & Cones	241

PRODUCT	PAGE	PRODUCT	PAGE
Mops		Thermometers	258, 262-263
Cut End	239	Timers	263
Looped End	237-238	Tongs	193
Mop Handles	240	Top Loaders	185-186
Mopping Signs & Cones	241	Tray & Silverware Dispensers	135
Mugs	27-28, 30, 33, 35	Tray Dispensers	133-134
Napkins	64-65, 67-69, 175, 177, 179	Tray Drying Racks	136
Napkin Sleeves	68-69, 71	Tray Tickets	70-71
Non-Skid Fiberglass Trays	43	Traycover Sizes	62-63, 66
Perfect•Serv Ultra Bulk Food Retherm System	94	Traycover Templates	60-61
Support Cart	95	Trays	
Transfer Dolly	94	Antimicrobial Protection	46
Pitchers	169	Custom Decorated	47
Plate Dispensers	128-132	Fiberglass	45
Plate Heaters	128-129	Low-Profile Room Service	45
Portable Bar	170	Meals on Command II	46, 93
ProCap Glassware Covers	53	Non-Skid Fiberglass	43-44
Protection, Heat & Chemical		Thermal•Aire III	46, 93
Apron	268	Tropez High Heat Ware	34-35
Full Body Kit	226	Tulip Cups & Bowls	41-42
Gloves	268	Tumblers	31, 38-40
Hot Pads	267	Turnbury Collection	29-30
Kevlar Sleeve	266	Underliners	37
Oven Mitts	267	ValuXpress Modular System	117-119
Gloves	268	Vinyl Table Coverings	174-175, 180
Racks		Washrack Dispensers	137
Dome/Base/Underliner Drying & Storage	136	Washracks	
Tray Drying & Storage	136	Color-Coded	219-222
Refrigerator, Air Curtain	122-123	Custom Racks	216-217
Retherm Systems	90-92, 94-95	Dish	223-224
Reusable Lids Washrack	31	Dispensers	137
Room Service Trays	45	Dust Cover	226
Scales	260-261	EZ-Glide Rack Dollies	226
Scoops	257	Glass	219-222
Shock Freezer/Blast Chiller	124	Half Size Stack-All	225
Smart•Therm II	36	Hold Down Grid	225
Sneeze Guards	113-116	NeWave	219
Squeegees, Floor	235	OptiClean Solutions	218
Starter Stations	79	Perma-San Flatware Washing Baskets	225
Storage Containers		Perma-Sil Cylinders & Carriers	225
Bains Maries	207	Rack Cover	226
StorPlus Boxes	204-205	Reusable Lid	31
StorPlus Rounds	206	Waste Containers	
StorPlus Square	203	Bronco Cans & Lids	248
Table Coverings	174-177, 180-181	Dollies	249
Table Skirting & Accessories	178	TrimLine	249
Thermal•Aire III	90-92	Wet Floor Signs & Cones	241
Cart	83, 91		
Patient Trays	46		

CFS BRANDS®

THE LEADER IN

FoodService Healthcare Janitorial

CFS Brands unites the leading names in foodservice,
healthcare and janitorial.

CFS Brands is building the foremost platform for light equipment and supplies – bringing professional-grade product solutions to customers around the globe. Our companies include Carlisle FoodService Products, San Jamar, Dinex, Sparta Brush, Marko, Snap Drape and others.

With Dinex as the platform of innovative and efficient meal delivery systems, CFS Brands enables comprehensive assortments of foodservice and sanitary maintenance products to increase patient and resident satisfaction and provide the most operationally effective meal delivery system in healthcare.

SERVE
PREPARE
PROTECT
DELIVER
DISPENSE
CLEAN



THE 4 TEAM APPROACH

From dock to dining our industry leading four team approach incorporates years of experience to help you meet your goals.

- **Custom Engineering.** Our engineers provide detailed drawings and specs with standard and customized products designed to meet your expectations.
- **Temperature Optimization.** Our equipment is designed to keep hot food hot and cold food cold for the best outcomes with meal quality.
- **Consultation.** Your local Dinex certified sales representative stays on top of the latest equipment and trends to recommend the best solution for your operation.
- **Culinary Support.** Our experienced chefs work with you on project designs all the way through hands on installation and training.



CUSTOM
ENGINEERING



TEMPERATURE
OPTIMIZATION



CONSULTATION



CULINARY
SUPPORT

DINEX®

ACUTE CARE SOLUTIONS

From an efficient tray assembly to patient meal delivery Dinex can help you with a large array of solutions to address all areas of hospital dining experience.

Tray Assembly Area



Meal Delivery



Cafeteria All Day Dining



Late Trays



Offsite Feeding Satellite



LONG-TERM CARE SOLUTIONS

When it comes to meal time, long-term care facilities are offering residents more independence in letting them choose when they eat. Some facilities are implementing buffet-style dining, 24-hour room service, and open access food in common areas through kiosks and snack carts. Dinex will work with you to put together the right plan to address these new challenges.

Dining Room



Tabletop



Room Service



Snack & Beverage



All Day Dining



Social Events



PATIENT TRAY ASSEMBLY



LOOKING TO UPGRADE YOUR KITCHEN TRAYLINE AREA?

Culinary support is ready to demonstrate the latest lean trends in quality and efficient service for optimal food temperature and freshness.



Our team of experienced chefs are here to assist you in developing **a food service program to help raise your patient satisfaction scores**

Need assistance upgrading your patient tray assembly service?

Here are some key products Dinex can offer to help you gain in efficiency.

- Drying & Storage Carts
- Dinex induction charger for hot temperature holding
- Hot Food Counter
- Induction Base Drying Rack
- Table For Induction Charger
- Convection Heated Plate Dispensers
- Starter Station (Straddle Style)
- TQ Cart Single Door Tray Delivery Carts With Two Trays Per Slide
- Value Line Solid Top & Beverage Urn Stand Counters
- Cantilever Style Tray Dispenser
- Air Curtain Refrigerator



page 102-105
Back-Of-House Hot Food Counter with Drop Down Work Shelf



Contact your sales representative for a layout **customized** to your organization and bed count.

Download the Dinex Healthcare Solutions App

See sample layouts of patient tray assemblies or hospital cafeterias and explore the solutions Dinex can offer to the Healthcare foodservice industry. Easily access product videos and sales literature within the app or email it.

Download for free from the App Store or Google Play



ELEVATE YOUR DINING EXPERIENCE

Dinex brings hospitality to healthcare
foodservice with innovative products that
provide an at home or hotel style experience.



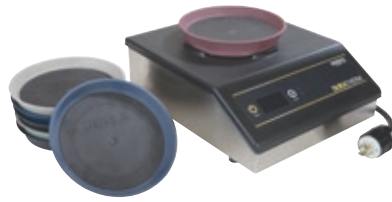

**DuraTherm
Induction System**
(page 36)

**Delivering the Best
Performance in Food
Holding Temperatures
and Quality:**

Dinex has the most innovative induction solution to keep food hot without compromising quality or menu selection.



Traytop Products
(page 24)

**Modern Styling and
Cost Saving Benefits:**

Dinex changed the industry by offering more designs and color choices than any other manufacturer. Our goal is to provide a clean and organized meal setting that maintains food quality and enhances patients' meal experience.



**TQ (Totally Quiet)
Supreme Meal
Delivery Carts**
(page 142)

Enhance Hospitality Quietly:

Dinex provides a solution to promote foodservice programs with carts that coordinate with your decor.

ACTIVE HOT
AND COLD
FOOD HOLDING
ON TRAYS





Meals on
Command II Cart
(page 82)

**Flexibility and
Time Savings:**

Keep your hot food hot
and cold food cold on trays
anywhere in your facility
with Meals on Command II.



Tropez Traytop
(page 34)

Hotel Style:

Tropez elegant design and
state-of-the art materials
will bring patient experience
to the next level.



Retrieval Cart
(page 82)

Tray Retrieval:

Our heavy duty retrieval cart
will offer a perfect solution
for soiled tray pick-up

BOOSTING,
SATELLITE AND
COOK-CHILL FOR
PATIENT MEALS
ON TRAYS





**Thermal•Aire III Dock
& Thermal•Aire III Cart**
(pages 90)

Innovation and Versatility:

Solve your hot and cold temperature challenges once for all with Thermal Aire III and its boosting and cook-chill capabilities.



Tropez Traytop
(page 34)

Hotel Style:

Combine your Thermal Aire III system with the elegant Tropez traytop design to enhance the patient experience.



Tray Retrieval
(page 82)

Tray Retrieval:

Our heavy duty retrieval cart will offer a perfect solution for Thermal•Aire soiled tray pick-up

MEAL DELIVERY IN A COMMUNITY SETTING

The aging population is making significant impacts on Senior Living Communities. Trends in Senior Living are driving restaurant-style experiences and changing equipment needs.





**MealtimeXpress
Carts**
(page 84)

Your Kitchen on Wheels:

MealtimeXpress provides residents freedom to choose the items and portions they desire to create a great dining experience.



Mingle Dinnerware
(page 165)

Mingle Dinnerware:

Mingle's brightly colored swirl design draws attention to the food and helps stimulate the resident's appetite.



**DineXpress
Counters**
(page 100)

**Modular Counters &
Meal Serving Solutions:**

DineXpress® offers a variety of counter styles and sizes ranging from a simple cashier stand to a customized buffet unit with cold well, soup wells and self-leveling plate and tray dispensers to create a hotel atmosphere in your healthcare facility.

FRONT-OF-HOUSE SOLUTIONS

For Cafeterias, Buffets, Grab 'N Go and Retail Foodservice

Look to DineX to provide solutions from grab 'n go to food courts and cafeterias. With its standard designs and customizable solutions, DineX has the solution to help increase your retail revenue.





DineXpress Hot or Cold Food Counters

Look to the DineX team to provide the solutions you need for everything from self-serve buffets to cafeterias, catering events, food courts and much more. Our equipment and products are versatile, durable and flexible to meet your requirements.

- Available from 2 to 6 wells
- Cold food counters are the most versatile and adaptable accessory on the serving line
- Hot counters can include optional induction countertop
- Optimal laminates and engineered stone tops can be added to compliment your space



DineXpress Food Counters

(page 106)



Trendy Dinnerware Options

(page 162)



Grab 'N Go

(page 54)

OPERATIONAL EFFICIENCY AND TRENDY TABLETOP SOLUTIONS WITH CARLISLE FOODSERVICE PRODUCTS

BACK OF HOUSE

- Professional Cookware
- Kitchen Accessories

- Storage & Handling Supplies
- Warewashing Products



FRONT OF HOUSE

- Dinnerware
- Drinkware
- Tabletop Accessories

- Marko Table Covers
- Displayware
- Food Bars & Convenience Products

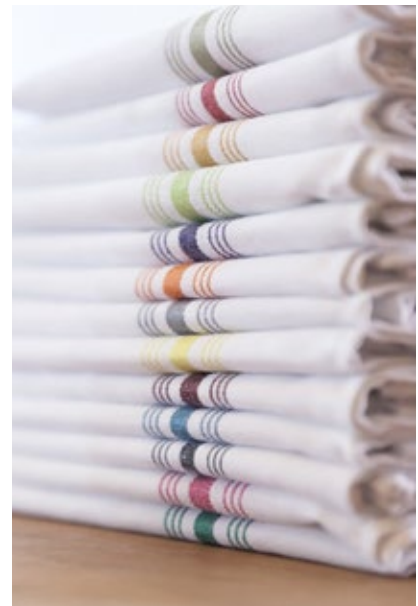

SAN JAMAR PROFESSIONAL-GRADE SOLUTIONS WITH PRACTICAL DAY-IN-DAY-OUT VALUE FOR AN EFFICIENT, SAFE AND PROFITABLE FACILITY

FOOD SAFETY

- Color-Coded Solutions
- Safe Ice Handling
- Safe Food Preparation
- Allergen Safety
- Sanitation Tools
- Measurement Tools



EMPLOYEE SAFETY

- Cut Protection
- Temperature Protection
- Chemical Protection
- Towel Dispensers
- Soap Dispensers
- Air Care



DINEX PARTNERSHIP & CONSULTATIVE PROGRAM

Dinex offers an extensive array of meal delivery solutions to help acute care and long-term care facilities accomplish their goals:

- Enhance guests' food experience and get higher HCAHPS scores
- Optimize food serving temperatures
- Identify opportunities to run a more efficient tray assembly operation
- Directly save cost revenue.

Let us partner with you. Our expert team of Dinex-Certified sales representatives and Corporate Chefs will listen and help you achieve all of your goals, using standard or customized products and solutions that will fit your needs.

Standard

Dinex offers the largest assortment of meal delivery solutions in the industry from support equipment for your tray assembly system to meal delivery carts.



Product Specifications
Can Be Customized

Dinex can also address your specific needs with customized products. All products in the catalog marked with this logo can be customized if needed.



Standard Starter/
Checker Station

page 156



Custom Stainless Table
Shown with optional Double
Overhead Shelves and Bins

page 157



Standard DineXpress

Shown with Optional Adjustable
Sneeze Guard, Solid-Ribbed Tray
Slide, Base Skirting, Engineered
Stone Top and Laminate Panels

page 100



Custom Front-of-House
DineXpress

page 100



TQ Supreme

page 142



Custom TQ
Supreme Graphics

Overall size of TQ Supreme cannot
change unlike TQ and Value Line Carts

Specifications of our regular TQ Carts
and Value Line Carts can be customized

page 143



Our team of experienced chefs are here to assist you in developing a food service program to help raise your patient satisfaction scores. From POD design and implementation to Trayline efficiency, our Culinary Team is here to assist you in achieving the highest patient satisfaction scores possible. We are able to utilize our experience and best practices to guide your facility to operate at its peak performance. We are here to support you and ready to start the conversation.

Connect with us!



Visit our website
www.carlislefsp.com



Check out our channel
at Carlisle Food
Service Products



Download our App
from the App Store or
Google Play



DINEX

BEAUTIFUL
UNIQUE
FUNCTIONAL
VARIETY

TRAYTOPS & ACCESSORIES

Need to increase patient satisfaction scores? Dinex can show you how with our coordinated collection of insulated domes, mugs, bowls, and trays. Dinex offers more unique designs than anyone in the industry with tray settings that are both trendy and functional.





DINEX® FENWICK COLLECTION

Increase patient satisfaction scores with our newest design. Fenwick's sleek, sculptured design and contemporary color choices **add to the overall patient experience.**

- Unique, exclusive design
- Double-wall insulated with ozone-safe, urethane foam
- For hot or cold foods and beverages
- Dishwasher safe
- Not recommended for microwave
- Dinex offers drying and storage racks, see page 136 for complete information
- See page 58 for coordinating traycovers and napkins



Customers who purchase Fenwick Wares also purchase TQ Supreme Carts.

NEW DESIGN



Fenwick Traytop in Onyx with Gray Marbled Non-Skid Tray
Our new Graphite color has an added metallic shimmer

Fenwick Insulated Entrée Dome

- Updated dome design includes a molded-in handle and improved stacking
- For 9" plate service with
 - Insul-Base, DX1077
 - Underliner/Wax Base, DX1087/TMP1097A
 - Induction Base, DX1411 and DX821 series
 - Cool Base, DXCBE



DX5400

Fenwick Dome Serving Height (on standard patient tray)

- Dome only: 2.88"
- With SmartTherm Base: 4.20"
- With DuraTherm Base: 4.25"
- With Insul-or Cool Base: 4.25"
- With Wax Base Underliner: 4.75"

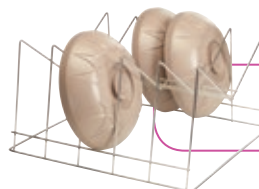

Drying & Storage Racks
page 136

See pages 36-37 for a complete listing of available bases and underliners

Fenwick Ware in Kid's Colors

Make mealtimes fun again with Fenwick insulated wares in bright, fun colors for kids. The 8 oz. mugs, 5 oz. bowls and 9 oz. bowls come packed with two colors to create a fun mismatched look on the traytop. Pair these with a base and insulated dome in graphite or midnight blue and the Jenny Park traycover to create a unique presentation.



**NEW
PRODUCT**



Coordinate your bright colored traytop with TQ Supreme custom graphics program

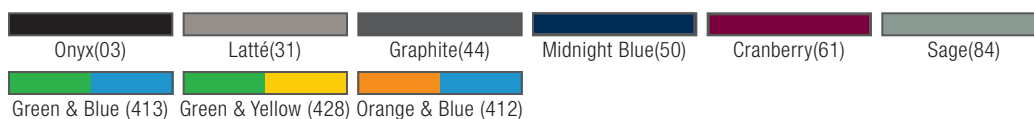

Prod No	Description	Disposable Lid	Glass Rack	Color	Diameter /Height	Pack
Fenwick Insulated Entrée Dome						
DX5400	Fenwick Insulated Dome	—	RPC	03, 31, 44, 50, 61, 84	10.00"/2.88"	12 ea
Fenwick Ware in Kid's Colors						
DX5000	Fenwick 8 oz. Insulated Mug, Green & Blue Combo	DX50008714, DX50008775	RC16-1	413	3.50"/3.50"	48 ea
DX5200	5 oz. Fenwick Insulated Bowl, Green & Yellow Combo	DX50008714, DX50008775	RW20	428	3.50"/2.50"	48 ea
DX5300	9 oz. Fenwick Insulated Bowl, Orange & Blue Combo	DX53008714	RG9	412	4.50"/2.50"	48 ea

DINEX® FENWICK COLLECTION



Fenwick Insulated Mug & Bowls

- Mug has heavy-duty handle to allow secure, three finger holding with thumb rest
- Built in foot for water drainage

Fenwick Disposable Lids

- **Tight fitting** disposable lids designed exclusively for the Fenwick Collection
- Manufactured from sturdy, high density material
- New Fenwick lids in clear for insulated wares adds a more upscale look to your traytop while allowing easy viewing of contents.



Dinex disposable lids are manufactured in an NSF certified GMP facility. This assures the products you are using were manufactured in an environment that is contamination and pest free.

Fenwick Tumblers & Cups

- Coordinating tumblers and cup available in durable, dishwasher safe SAN
- Tumblers have **convenient 2 oz markings** for fluid intake management
- **See page 38 for a complete listing of tumblers and cups**



DuraTherm™ Soup Lid

- Space saving design fits over the disposable lid
- Holds soup temperatures over 140°F degrees for up to 75 minutes
- Fits both Turnbury and Fenwick 9 oz Bowls
- Wash, dry and store with standard ware items



Prod No	Description	Disposable Lid	Glass Rack	Color	Diameter /Height	Pack
Fenwick Insulated Mug & Bowls						
DX5000	8 oz Fenwick Insulated Mug	DX50008714, DX50008775	RC16-1	03, 31, 44, 50, 61, 84	3.50"/3.50"	48 ea
DX5200	5 oz Fenwick Insulated Bowl	DX50008714, DX50008775	RW20	03, 31, 44, 50, 61, 84	3.50"/2.50"	48 ea
DX5300	9 oz Fenwick Insulated Bowl	DX53008714	RG9	03, 31, 44, 50, 61, 84	4.50"/2.50"	48 ea
Disposable Lids						
DX50008714	Translucent Lid (fits DX5000, DX5200)	—	—	—	—	1,500 ea
DX50008775	EZ-Sip White Lid (fits DX5000, DX5200)	—	—	—	4" w/Mug	1,000 ea
DX53008714	Translucent Lid (fits DX5300)	—	—	—	—	1,000 ea
DX50008700	Fenwick Clear Lid (fits DX5000, DX5200)	—	—	—	—	—
DX53008700	Fenwick Clear Lid (fits DX5300)	—	—	—	—	—
DuraTherm Soup Lid						
DX3353IL	Insulated Lid for Soup Bowl - Fits DX3300 and DX5300 (use with disposable lid)	—	RG9	03, 44	5.25"/1.5"	48 ea

DINEX® TURNBURY® COLLECTION

Choose Turnbury for its **distinctive swirl design** that is an **industry best-seller**.

- Distinctive swirl design with the elegant look of china
- Double-wall insulated with ozone-safe, urethane foam
- For hot or cold foods and beverages
- Dishwasher safe
- Not recommended for microwave
- DineX offers drying and storage racks, see page 136 for complete information
- See page 58 for coordinating traycovers and napkins

Turnbury Insulated Entrée Dome

- Updated dome design includes a molded-in-handle and improved stacking
- For 9" plate service with
 - Insul-Base, DX1077
 - Underliner/Wax Base, DX1087/DXTMP1097A
 - Induction Base, DX1411 and DX821 series
 - Cool Base, DXCBE

Turnbury Dome Serving Height (on standard patient tray)

Dome only: 2.88"

With SmartTherm Base: 4.20"

With DuraTherm Base: 4.25"

With Insul or Cool Base: 4.25"

With Wax Base Underliner: 4.75"

See pages 36-37 for a complete listing of available bases and underliners



DX3400

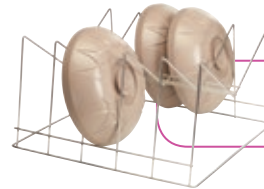

Drying & Storage Racks

page 136

Turnbury Traytop in Latté with Non-Skid Tray in Black Marbled





DINEX® TURNBURY® COLLECTION

Turnbury Insulated Mug & Bowls

- Mug has heavy-duty handle to allow secure, three finger holding with thumb rest

Disposable Lids

- **Tight fitting** disposable lids designed exclusively for the Turnbury Collection
- Manufactured from sturdy, high density material

Reusable Lids

- Tight fitting reusable lids are an **eco-friendly solution** that helps cut down on yearly costs
- Dishwasher safe, 100% recyclable



Use DuraTherm Lids with 9 oz Soup Bowl to extend your holding time on hot foods



Dinex disposable lids are manufactured in an NSF certified GMP facility. This assures the products you are using were manufactured in an environment that is contamination and pest free.



Prod No	Description	Disposable Lid	Glass Rack	Color	Diameter /Height	Pack
Turnbury Insulated Entrée Dome						
DX3400	Turnbury Insulated Dome	—	RPC	03, 08, 31, 50, 61, 84	10.00"/2.88"	12 ea
Turnbury Insulated Mug & Bowls						
DX3000	8 oz Turnbury Insulated Pedestal Base Mug	DX30008714, DX30008775	RC16-1	03, 08, 31, 50, 61, 84	3.50"/4.00"	48 ea
DX3200	5 oz Turnbury Insulated Pedestal Base Bowl	DX30008714, DX30008775	RG20	03, 08, 31, 50, 61, 84	3.50"/2.38"	48 ea
DX3300	9 oz Turnbury Insulated Pedestal Base Bowl	DX33008714, DX11830174	RG9	03, 08, 31, 50, 61, 84	4.38"/2.38"	48 ea
Disposable Lids						
DX30008714	Translucent Lid (fits DX3000, DX3200)	—	—	—	—	1,500 ea
DX11830174	Clear-view Dome Lid (fits DX3300)	—	—	—	—	1,000 ea
DX30008775	EZ-Sip White Lid (fits DX3000, DX3200)	—	—	—	4.38" w/Mug	1,000 ea
DX33008714	Translucent Lid (fits DX3300)	—	—	—	—	1,000 ea
DuraTherm Soup Lid						
DX3353	DuraTherm Insulated Soup Lid (fits DX5300, DX3300) (use with disposable lid)	—	RG9	03, 44	—	48 ea

Swirl Tumblers & Cups

- Coordinating tumblers and cups available in durable, dishwasher safe SAN
- Tumblers have **convenient 2 oz markings** for fluid intake management
- Dishwasher safe
- **See page 38 for a complete listing of tumblers and cups**



DXSWC5



Washracks For Reusable Lids

- Washracks make washing and storing reusable lids **easy** and **efficient**
- Clamshell washrack insert with latch **holds 36 lids**
- Separates and holds lids in place while washing
- Inserts are stackable



Use the Lid Washrack for cleaning Reusable Lids



Use alone or fit three inside Carlisle's OptiClean Rack RB114

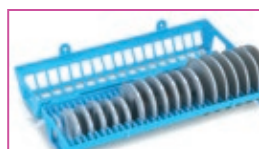

DXRLWR114



Blue(14)

Prod No	Description	Disposable Lid	Glass Rack	Color	Diameter/Height	Pack
Reusable Lids						
DX3000RL	Reusable Flat Lid (fits DX3000, DX3200)	—	DXRLWR1	—	5.25"/1.5"	250 ea
DX3300RL	Reusable Flat Lid (fits DX3300)	—	DXRLWR1	—	—	250 ea
Washrack For Reusable Lids						
DXRLWR1	Washrack For Reusable Lids	—	—	14	—	6 ea



DINEX® HERITAGE COLLECTION®

Choose Heritage for its **faceted styling**, ease of use and **superior heat retention**.

- **Contemporary faceted styling** and a china-like appearance
- Double-wall insulated with ozone-safe, urethane foam
- For hot or cold foods and beverages
- Dishwasher safe
- **Stackable**
- Not recommended for microwave
- Dinx offers drying and storage racks, see page 136 for complete information
- See page 58 for coordinating traycovers and napkins



Heritage Traytop in Onyx shown with Cranberry Solid Traycover

Heritage Insulated Entrée Dome

- Features molded-in handle and high food clearance
- For 9" plate service with
 - Insul-Base, DX1077
 - Underliner/Wax Base, DX1087/DXTMP1097A
 - Induction Base, DX1411 and DX821 series
 - Cool Base, DXCBE



DX4400 Insulated Dome

Heritage Dome Serving Height (on standard patient tray)

Dome only: 2.75"

With SmartTherm Base: 4.20"

With DuraTherm Base: 4.25"

With Insul or Cool Base: 4.25"

With Wax Base Underliner: 4.5"

See pages 36-37 for a complete listing of available bases and underliners

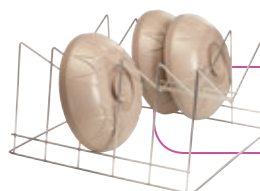

Drying & Storage Racks

page 136



Heritage Insulated Mug & Bowls

- Mug has heavy-duty handle to allow secure, three finger holding with thumb rest

Disposable Lids

- **Tight fitting** disposable lids designed exclusively for the Heritage Collection
- Manufactured from sturdy, high density material

NSF
 Dinex disposable lids are manufactured in an NSF certified GMP facility. This assures the products you are using were manufactured in an environment that is contamination and pest free.



Prod No	Description	Disposable Lid	Glass Rack	Color	Diameter/Height	Pack
Heritage Insulated Entrée Dome						
DX4400	Heritage Insulated Dome	—	RPC	03, 50, 61	10.00"/2.88"	12 ea
Heritage Insulated Mug & Bowls						
DX4000	8 oz Heritage Insulated Stackable Mug	DX40008700, DX40008714	RC20-1	03, 50, 61	Lip: 2.75"/Base: 3.75"/4"	48 ea
DX4200	5 oz Heritage Insulated Stackable Bowl	DX40008700, DX40008714	RG16	03, 50, 61	Lip: 2.75"/Base: 3.75"/2.5"	48 ea
DX4300	9 oz Heritage Insulated Stackable Bowl	DX43008714, DX43008700	RG9	03, 50, 61	Lip: 3.5"/Base: 4.5"/2.5"	48 ea
DX4500	12 oz Heritage Insulated Stackable Bowl	DX11858700, DX11858714	RG9	50, 61	Lip: 2.75"/Base: 4.5"/3"	48 ea
Disposable Lids						
DX40008700	Clear-view Flat Lid (fits DX4000, DX4200)	—	—	—	—	2,000 ea
DX40008714	Translucent Lid (fits DX4000, DX4200)	—	—	—	—	2,000 ea
DX43008700	Clear-view Flat Lid (fits DX4300)	—	—	—	—	1,000 ea
DX43008714	Translucent Lid (fits DX4300)	—	—	—	—	1,000 ea
DX11858700	Clear-view Flat Lid (fits DX4500)	—	—	—	—	1,000 ea
DX11858714	Translucent Lid (fits DX4500)	—	—	—	—	1,000 ea



DINEX® TROPEZ® HIGH HEAT WARE

Choose Tropez for its **elegant design** and state-of-the-art materials. It's a **complete solution** for convection holding re-thermalization and cook-chill systems.

- A specialty line of high temperature, non-insulated ware for patient meal service
- Constructed of special high heat resin to ensure safe and efficient heating up to 300°F
- Dishwasher safe
- See page 58 for coordinating traycovers and napkins

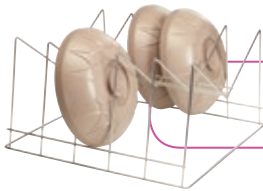

Drying & Storage Racks
page 136

Tropez High Temp Reusable Entrée Domes

- Contemporary style entrée dome
- Features molded-in handle and high food clearance
- Two sizes available to fit 7.75" and 9" plates

DX9407B



Tropez Entrée Dome Serving Heights (measured on standard patient tray)

DX9407B 7.75" Dome

Dome only: 2.5", Dome With China Plate: 3"

DX9400B 9.50" Dome

Dome only: 2.25", Dome With China Plate: 4.13"

DX9400B

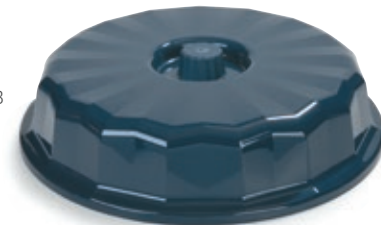



DX9200B



DX9300B



DX9000B

Tropez High Temp Reusable Mug & Bowls

- Mug has heavy-duty handle to allow secure, three finger holding with thumb rest

Tropez High Temp Disposable Lids

Dinex high heat disposable lids are microwavable and can be used in retherm or other heated cart systems. They feature a natural color and are made with natural additives, reducing the use of plastic by 45%.

- Tight fitting disposable lids designed exclusively for the Tropez Collection
- Manufactured from sturdy, high density material



Thermal Aire Cart

Meals On Command II Cart

Dinex high heat disposable lids can be used in our Thermal Aire system or our Meals On Command carts shown on page 82.



Dinex disposable lids are manufactured in an NSF certified GMP facility. This assures the products you are using were manufactured in an environment that is contamination and pest free.



Prod No	Description	Disposable Lid	Glass Rack	Color	Diameter /Height	Pack
Tropez High Temp Reusable Entrée Domes						
DX9407B	7.75" Tropez High Temp Dome	—	RFP	03, 50, 61	7.75"/2.50"	12 ea
DX9400B	9.50" Tropez High Temp Dome	—	RFP	03, 50, 61	9.50"/2.25"	12 ea
Tropez High Temp Reusable Mug & Bowls						
DX9000B	8 oz Tropez High Temp Mug	DX9000B7000	RC16	03, 23, 50, 61	3.38"/2.88"	48 ea
DX9200B	5 oz Tropez High Temp Bowl	DX9000B7000	RW20	03, 50, 61	3.38"/2.88"	48 ea
DX9300B	9 oz Tropez High Temp Bowl	DX9300B7000	RG9	03, 50, 61	4.50"/2.25"	48 ea
Disposable Lids						
DX9000B7000	Disposable Lid (fits DX9000B, DX9200B)					1,000 ea
DX9300B7000	Disposable Lid (fits DX9300B)					1,000 ea



DINEX® BASES, UNDERLINERS & ACCESSORIES

Keep Cool with the **freezable Cool Base**; the ideal solution for chilled entrées. Patients and residents will love their **crisper, fresher salads**.

Cold Holding

Cool Base

- **An industry first**
- Keeps food cold for up to an hour when used with the clear PC dome or for up to 90 minutes when used with an insulated dome
- Quick freeze time of two hours
- Holds standard 9" plate
- Compatible with insulated domes or plate covers
- Gray color for easy identification and coordination with existing ware color
- Sturdy construction and standard **one year warranty**
- Dishwasher safe

Hot Holding

Induction Base

Smart•Therm II & DuraTherm bases work with our superior induction systems to help hold proper temperatures

- See page 75 for a complete listing of induction bases and their features



DXCBE Cool Base shown with DXEC09 dome lid and salad plate

A Clear Dome is the perfect companion for Cool Base

- Provides an economical solution for serving salads, sandwiches and other cold food items
- Maintains cold food temperatures for up to 60 minutes when used with Cool Base
- Compatible with all Dinex bases
- Easy grip handle
- Sturdy polycarbonate construction and standard one year warranty
- Dishwasher safe

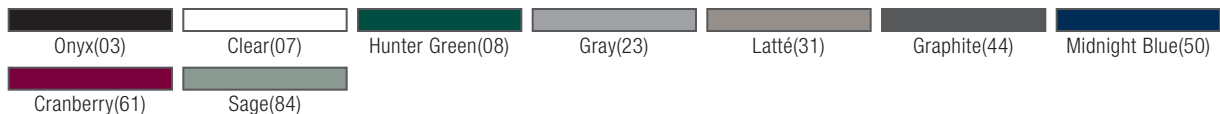

Prod No	Description	Color	Diameter	Height	Pack
Cool Base					
DXCBE	Cool Base	23	9.00	—	12 ea
DXEC09 ♦	Entree Dome Cover with Handle	07	—	—	12 ea
SmartTherm Induction Base					
DX8210 Δ	Induction Base	03, 08, 31, 44, 50, 61, 84	9.75	1.63	12 ea
DuraTherm Induction Base					
DX14110 Δ	Induction Base	03, 31, 44, 50, 61, 84	9.75	1.63	12 ea

Dinex by CFS Brands NSF Listed products are designated with a Δ and may be prefixed with an N

♦ California Residents: Bisphenol A **WARNING:** See appendix A on page 281

Wax Base

- Highly durable 20-gauge, 304 stainless steel
- Exclusive specialized wax compound ensures fast heat up
- Holds food temperature up to 90 minutes
- NSF Listed



DXTMP1097A



Underliner

- Sturdy single-wall construction to hold the Dinex wax base
- Protects patients and chilled foods from heated base



DX1087

Insul-Base

- For standard 9" plates
- Double-wall insulated with ozone-safe, urethane foam
- Fits with all Dinex entrée domes
- Combine with heated plate and insulated dome to keep food hot or cold up to 25 minutes
- Dishwasher safe



DX1077

Note: Insul-Base should not be used as a liner for wax bases

Accessories



DXTMPHNDLIFT
DXTMPLIFTER

DXK335C9



Prod No	Description	Color	Diameter	Height	Pack
Wax Base					
DXTMP1097A Δ	9" Wax Base	—	7.75"	1.5"	12 ea
Underliner					
DX1087	Pellet Underliner for Insulated Domes	03, 08, 31, 44, 50, 61, 84	9.5"	1.88"	12 ea
Insul-Base					
DX1077	Insul-Base for Insulated Domes	03, 08, 31, 50, 61, 84	9.5"	1.75"	12 ea
Accessories					
DXTMPHNDLIFT	Base Lifter, Palm Grip	—	—	—	1 ea
DXTMPLIFTER	Base Lifter, Wand Grip	—	—	—	1 ea
DXTMPVACCUP3	3" Replacement Cup, Hand Style	—	3"	—	1 ea
DXTMPVACCUP4	4" Replacement Cup, Wand Style	—	4"	—	1 ea
DXK335C9	Heat Resistant Gloves for Wax Bases & Plates	—	—	—	12 pr

Dinex by CFS Brands NSF Listed products are designated with a Δ and may be prefixed with an N



TUMBLERS & LIDS

Only Dinex has a complete collection of tumblers and lids in every design, size and color to meet your patient needs.

- Tumblers available in durable, BPA Free SAN
- Fenwick and Swirl styles feature convenient 2 oz markings for fluid intake management
- Stackable & dishwasher safe





Dinex® Fenwick

Complete The Fenwick Look

- Modern drinkware with a crystal like design to match Fenwick insulated ware shown on page 38

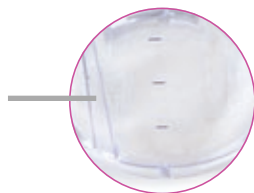
2 oz markings (on Fenwick & Swirl Tumblers) help monitor fluid intake





Dinex disposable lids are manufactured in an NSF certified GMP facility. This assures the products you are using were manufactured in an environment that is contamination and pest free.

Disposable Lids

- **Tight fitting** disposable lids designed to fit Dinex tumblers
- Manufactured from sturdy, high density material



Clear(07)

Prod No	Description	Disposable Lid	Glass Rack	Color	Diameter /Height	Pack
Fenwick Tumblers						
DXFT6	6 oz Fenwick Tumbler	DX5600ST8714	RG36	07	2.50"/3.00"	72 ea
DXFT9	9 oz Fenwick Tumbler	DX5900ST8714	RG25-1	07	3.25"/3.50"	72 ea
DXFT12	12 oz Fenwick Tumbler	DX5900ST8714	RG25-1	07	3.25"/4.00"	72 ea

Prod No	Description	Fits	Pack
Disposable Lids			
DX5600ST8714	Translucent Lid with Straw Slot	DXFT6	1,000 ea
DX5900ST8714	Translucent Lid with Straw Slot	DXFT9, DXFT12	1,000 ea

Dinex® Swirl

Complement Turnbury Wares

- Swirl design coordinates with Turnbury insulated ware shown on page 29
- Now available in a variety of colors to help identify contents



Warewashing
pages 214-225



Louis Tumbler

Top-of-the-line Elegant Style

- Glass like appearance
- Faceted shape offers easy grip
- NSF Listed



Prod No	Description	Disposable Lid	Glass Rack	Color	Diameter/Height	Pack
Swirl Tumblers						
DX4GC6	6 oz Swirl Tumbler	DX11968714, DX1196ST8714	RG36-1	07, 54	2.63"/3.25"	72 ea
DX4GC8	8 oz Swirl Tumbler	DX11968714, DX1196ST8714	RG36-1	07, 54	2.62"/4.03"	72 ea
DX4GC9	9 oz Swirl Tumbler	DXTT58	RG25-1	07, 54	3.25"/3.38"	72 ea
DX4GC12	12 oz Swirl Tumbler	DXTT58	RG25-1	07, 54	3.25"/4.13"	72 ea
Louis Tumblers						
DX5806 Δ	6 oz Louis Tumbler	DX1191ST8714	RG36-1	07	2.62"/3.5"	72 ea
DX5808 Δ	8 oz Louis Tumbler	DX2225ST9000, DX22259000	RG36-1	07	3.00"/3.38"	72 ea
DX5810 Δ	10 oz Louis Tumbler	DX5810ST8714	RW30	07	2.88"/4.56"	72 ea
DX5812 Δ	12 oz Louis Tumbler	DX5812ST8714	RW20	07	3.38"/3.88"	72 ea

Prod No	Description	Fits	Pack
Disposable Lids			
DX1191ST8714	Translucent Lid with Straw Slot	DX5806	1,000 ea
DX22259000	Translucent Lid	DX5808	2,000 ea
DX2225ST9000	Translucent Lid with Straw Slot	DX5808	2,000 ea
DX5810ST8714	Translucent Lid with Straw Slot	DX5810	1,000 ea
DX5812ST8714	Translucent Lid with Straw Slot	DX5812	1,000 ea

Dinex by CFS Brands NSF Listed products are designated with a Δ and may be prefixed with an N



TUMBLERS

Textured Tumblers

Durable & Dependable

- Textured exterior hides wear and tear
- Tapered sides make tumblers easy to stack
- Interior lugs prevent jamming when stored
- **Colors help identify contents**

Crystalon

- Stylish ribbed texture offers better grip
- Low profile fits tight tray spacing

 Dinex disposable lids are manufactured in an NSF certified GMP facility. This assures the products you are using were manufactured in an environment that is contamination and pest free.



Clear(07)

Prod No	Description	Disposable Lid	Glass Rack	Color	Diameter/Height	Pack
Textured Tumblers						
DX5501	5 oz Textured Tumbler	DX1193ST8714	RG36-1	07	2.25"/3.62"	72 ea
DX5526	8 oz Textured Tumbler	DX1191ST8714	RG36-1	07	2.62"/3.94"	72 ea
DX5529	9 oz Textured Tumbler	DXTT58	RG25-1	07	3.25"/3.38"	72 ea
DX5506	9.5 oz Textured Tumbler	DX11988714, DX1198ST8714	RW30	07	2.75"/4.37"	72 ea
Crystalon Tumbler						
DX4GCOF9	9 oz Low Profile Crystalon Tumbler	DX21259000	RW20	07	3.31"/2.90"	48 ea

Prod No	Description	Fits	Pack
Disposable Lids			
DX21259000	Translucent Lid	DX4GCOF9	2,000 ea
DX2125ST9000	Translucent Lid with Straw Slot	DX4GCOF9	2,000 ea
DX1193ST8714	Translucent Lid with Straw Slot	DX5501	1,000 ea
DX11988714	Translucent Lid	DX5506	1,000 ea
DX1198ST8714	Translucent Lid with Straw Slot	DX5506	1,000 ea
DX11810174	Clear Dome Lid	DXSQD10	1,000 ea



TULIP CUPS & BOWLS

Add the **finishing touch** to your traytop with **attractive** cups and bowls that **enhance** appetite appeal and **improve** tray organization.

- Available in durable, dishwasher safe, BPA Free SAN
- Ideal for standard portions of salads, fruit or dessert



DXFC5

Fenwick

- **Modern** a crystal like design to match Fenwick collection shown on page 38



DXSWC8

Swirl

- Ever **popular swirl design** offers a coordinated place setting



DXSWC5



DXSWC6



DXSWC12

Square Bowl

- Space saving design fits nicely in the corner of trays



DXSQD10



Prod No	Description	Disposable Lid	Glass Rack	Color	Diameter/Height	Pack
Fenwick Cup						
DXFC5	5 oz Fenwick Cup	DX55000174	RG16	07	3.5"/2.25" (3" w/lid)	96 ea
DX55000174	Clear Dome Lid	Fits DXFC5				1,000 ea
Tulip Cup & Bowl (Swirl)						
DXSWC5	5 oz Tulip Cup	DX11820174	RG16	03, 07	3.5"	96 ea
DXSWC12	12 oz Tulip Bowl	DX11890174	RG9, RB	03, 07	5.5"/2.5" (3.13" w/lid)	48 ea
DXSWC8 Δ	8 oz Tulip Bowl	DX11870174	RG9	03, 07	4.63"/2.25" (3" w/lid)	48 ea
DXSWC6 Δ	5 oz Berry Bowl	DX11870174	RG9	07	4.63"/2.13" (2.88" w/lid)	96 ea
DX11820174	Clear Lid	Fits DXSWC5	—	—	—	1,000 ea
DX11890174	Clear Lid	Fits DXSWC12	—	—	—	1,000 ea
DX11870174	Clear Dome Lid	Fits DXSWC8, DXSWC6	—	—	—	1,000 ea
Square Bowl						
DXSQD10 Δ	10 oz Square Bowl	DX11810174	RG16	07	4" Sq/1.75"	48 ea

Dinex by CFS Brands NSF Listed products are designated with a Δ and may be prefixed with an N



BOWLS

Flared bowls have the look of china with the durability and cost savings of plastic. **Snap two lids together** to create a disposable dish and lid.

Square Bowl

- Available in 6 oz, 9 oz and 12 oz sizes in clear, black and white SAN
- One disposable lid fits all three sizes
- Snap two disposable lids together to create a 5 oz disposable dish with lid
- Bowls are NSF Listed
- Lid is AIB Certified



Lids Snap Together

The DX11840174 lid can be used as a condiment dish or snap together to create a 5 oz. dish and lid, perfect for your side items and desserts. Use the dish and lid on top of our DXSB12 bowl to create a parfait or use with veggies and dips.



Dinex disposable lids are manufactured in an NSF certified GMP facility. This assures the products you are using were manufactured in an environment that is contamination and pest free.



Prod No	Description	Disposable Lid	Glass Rack	Color	Diameter/Height	Pack
Square Bowls & Lids						
DXSB6 Δ	6 oz Square Bowl	DX11840174	RG16	02, 03, 07	4.1"/1.4" (2.3" w/lid)	96 ea
DXSB9 Δ	9 oz Square Bowl	DX11840174	RG16	02, 03, 07	4.1"/1.8" (2.7" w/lid)	48 ea
DXSB12 Δ	12 oz Square Bowl	DX11840174	RG16	02, 03, 07	4.1"/2.3" (3.2" w/lid)	48 ea
DX11840174	Clear Dome Lid for Square Bowls	Fits DXSB6, DXSB9, DXSB12	—	—	—	1,000 ea

Dinex by CFS Brands NSF Listed products are designated with a Δ and may be prefixed with an N

PATIENT TRAYS

A **breakthrough** in traytop dining. **Only Dinex** offers a truly **non-skid fiberglass tray** that can help **save money** by eliminating paper tray covers and present a **beautiful appearance** at the same time.

Non-Skid Fiberglass

- Features molded-on non-skid surface to keep items securely in place during transit
- Stain, scratch and odor resistant
- Non-fading print
- Dishwasher safe and easy to clean
- Non-metal brush suggested for scrubbing
- NSF Listed
- 2-year limited warranty



Tray Drying Rack
page 136

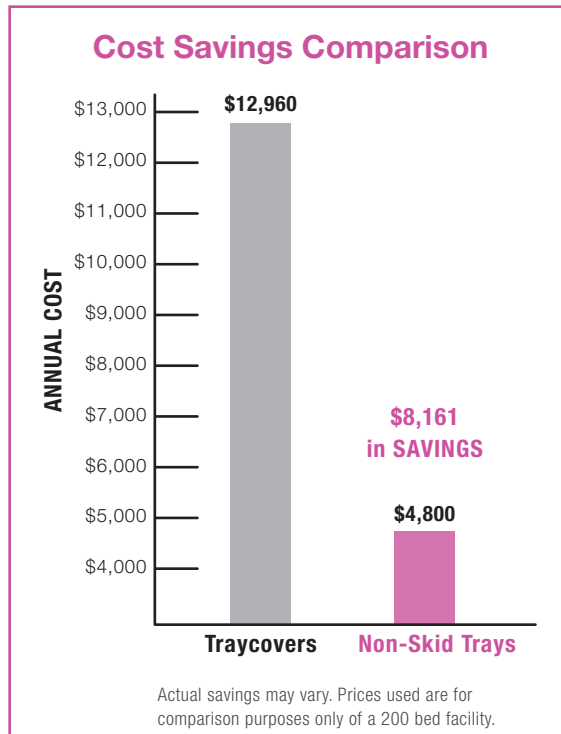



PATIENT TRAYS



Meal Delivery Carts – page 140

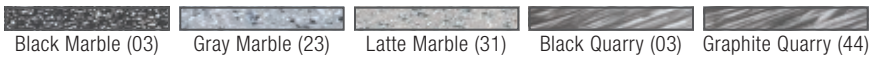

Prod No	Description	Color	Length	Width	Pack
Non-Skid Fiberglass Trays					
DXSMC1418NSM Δ	14" x 18" Non-Skid Marble Fiberglass Tray	03, 23, 31	14"	18"	12 ea
DXSMC1520NSM Δ	15" x 20" Non-Skid Marble Fiberglass Tray	03, 23, 31	15"	20"	12 ea
DXSMC1418NSQ Δ	14" x 18" Non-Skid Quarry Fiberglass Tray	03, 44	14"	18"	12 ea
DXSMC1520NSQ Δ	15" x 20" Non-Skid Quarry Fiberglass Tray	03, 44	15"	20"	12 ea

Dinex by CFS Brands NSF Listed products are designated with a Δ and may be prefixed with an N

Fiberglass

- Durable serving trays are molded from sturdy fiberglass
- Two thick reinforcing fiberglass core mats add strength and provide increased chemical resistance
- Trays can be decorated, see page 47 for more information
- Dishwasher safe
- NSF Listed



Traycovers
page 58

Fiberglass Tray 5 Year Warranty

Dinex warrants all of our Fiberglass (Glasteel) Trays for 5 years from the date of original purchase against breakage arising from normal use and service.

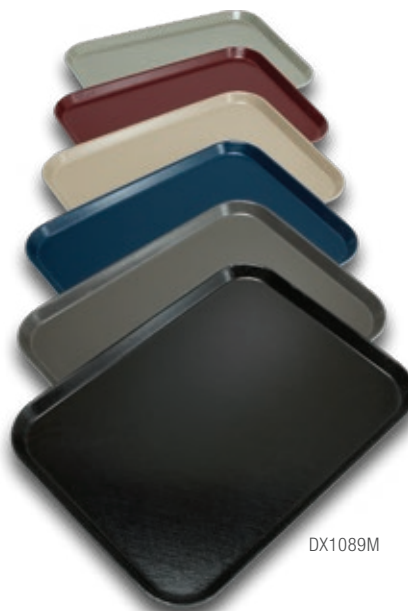

DX1089M

Low-Profile Room Service

- Available in textured and **molded-in** non-skid surfaces
- Reinforced rounded handles
- Trays are made of durable **polycarbonate**
- Stackable and dishwasher safe



DXRST1520NSQ



DXRST1520



DXSC1531002



Prod No	Description	Color	Length	Width	Pack
Fiberglass Trays					
DX1089I Δ	14" x 18" Flat Fiberglass Tray, Size I	03, 23, 31, 44, 50, 61	14"	18"	12 ea
DX1089M Δ	15" x 20" Flat Fiberglass Tray, Size M	03, 23, 31, 44, 50, 61	15"	20"	12 ea
Low Profile Room Service Trays					
DXRST1520 Δ \blacklozenge	15" x 20" Low Profile Room Service Tray	03	20"	15"	12 ea
DXRST1520NSQ Δ \blacklozenge	15" x 20" Non-Skid Low Profile Room Service Tray	03	20"	15"	6 ea

Dinex by CFS Brands NSF Listed products are designated with a Δ and may be prefixed with an N
Only Gray(23) is offered with antimicrobial protection

\blacklozenge California Residents: Bisphenol A **WARNING:** See appendix A on page 281



PATIENT TRAYS

Thermal•Aire III & Meals On Command II Patient Trays

- Specialty systems such as Thermal•Aire III and Meals On Command use high-quality trays configured specifically for this equipment



Antimicrobial Protection

- Trays with antimicrobial technology molded in to the tray are designed to help prevent the growth of stain and odor causing bacteria keeping the tray cleaner between washings
- Antimicrobial technology works continuously for 24/7 protection, keeping the food trays cleaner for longer and won't wash off or wear away, even when scraped
- Built-in antimicrobial protection makes the tray easier to clean and keeps it cleaner between washings
- Ergonomic design
- Please note antimicrobial protection does not protect users from foodborne illness and is not a substitute for normal cleaning practices



Prod No	Description	Color	Length	Width	Pack
Thermal•Aire III & Meals on Command II Patient Tray					
DXSC1531002	13" x 21" Individual Meal Tray	03, 23	13"	21"	24 ea
Meals On Command Split Tray					
DX1089MOC23	13.5" x 23" Meals On Command Tray	23	13.5"	23"	20 ea
Tray With Antimicrobial Protection					
DXSC1321MB	13" x 21" Tray with Antimicrobial Protection for Thermal•Aire III	03, 23*	13"	21"	24 ea

*Only Gray(23) is offered with antimicrobial protection

CUSTOM DECORATING

Carlisle offers a variety of options to customize the products that we produce. From screen printing to hot stamping, we can add your logo to items ranging from plates to trash cans.

For more information contact Carlisle Customer Service by phone at 1-800-654-8210 or via email at customerservice@carlislefsp.com

For a complete list of custom decorating options visit www.carlislefsp.com/customer-service/custom-decorating



Dinex is the only company coordinating the traytop to the cart.



Full color images printed on both sides of the tray





DINEX

ELEGANT
FUNCTIONAL
DURABLE
FINISHING-
TOUCH
**DISHWARE &
DISPOSABLE**

*Dinex is your complete source for trayservice.
Offering a collection of contemporary styled
china, disposable dishware and a large selection
of disposable lids designed to fit a variety of
insulated ware, bowls and tumblers.*





DINEX DINNERWARE

Dinex offers a wide range of dishware and disposable options. Paramount to our designs is the comfort and **satisfaction of your patients**. From **elegant** temperature-retaining china to **quality** cost-saving **disposables**, Dinex has the selection to fit the strictest food preparation requirements.

Narrow Rim Embossed China Dishware

- **Elegant Bright White** china featuring a narrow embossed rim
- Compatible with Dinex bases
- Dishwasher safe

Dinex® Wide Rim China Dishware

- **Elegant Bright White** china featuring a wide rim
- Compatible with Dinex bases
- Dishwasher safe

China Accessories

- **Fenwick disposable lids** in clear or translucent cover mugs and bowls for transport
- Casserole dishes in 6 oz or 10 oz fit on an entrée plate underneath an insulated dome cover



Disposable dome lid for fruit bowl and bread plate DX11880174



Prod No	Description	Color	Pack
Narrow Rim Embossed China Dishware			
DX5CBPB	5.5" Bread & Dessert Plate	02	36 ea
DX5CFNB	5.75 oz Fruit Bowl	02	36 ea
DX9CP	9" Entrée Plate	02	12 ea
Dinex Wide Rim China Dishware — Bright White			
DX5ACBP	5.5" China Plate	02A	36 ea
DX9ACP	9" China Plate	02A	24 ea
China Accessories			
DXHHC10	7.75" Entrée Plate	02	24 ea
DX6CASS	6 oz China Casserole	02A	36 ea
DX10CASS	10 oz China Casserole	02A	
DX11880174*	Disposable Clear Dome Lid for China Bread Plate & Fruit Bowl (fits DX5CBPB, DX5CFNB & DX5ACBP)	—	500 ea

*Disposable lids for china are not leak proof



Melamine Plate

- Attractive, **high quality melamine** dishware provides a safe and durable alternative to china
- Not recommended for use in microwave or plate heater
- Dishwasher safe



Disposable Dishware & Lids

- Manufactured and stored in the **strictest of sanitary conditions** to assure you receive pest and contamination free products
- The most sanitary disposables in the healthcare industry



High-Heat Disposable Dishware & Lids

- DineX high heat disposables are microwavable and can be used in retherm or other heated cart systems. They feature a natural color and are made with natural additives, reducing the use of plastic by 45%

Note: High-Heat Disposable Dishware is not safe to heat over 300°F

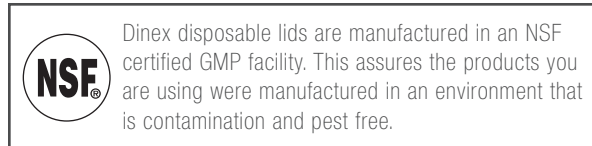

New high heat 7.75" narrow or wide rim plate and dome cover in black



Prod No	Description	Color	Pack
Melamine Plate			
DX4T9	9" Entrée Plate	02	24 ea
Disposable Dishware			
DXTT1	6 oz Side Dish, 5.25" x 4"	White	2,000 ea
DXTT6	4 oz Dessert Dish, 4" x 3.5"	White	4,000 ea
DXTT8	12 oz Rectangular Entrée Dish, 7.5" x 5.25"	White	1,000 ea
DXTT20	8 oz Rectangular Soup Bowl, 4.75" x 3.5"	White	1,000 ea
DXTT30	Rectangular Soup Bowl Lid (fits DXTT20), 4.75" x 3.5"	Translucent	1,000 ea
High-Heat Disposable Dishware			
DXHH10	7.75" Entrée, One Compartment	Natural	500 ea
DXHH10A	7.75" Entrée, One Compartment (for Aladdin Excel Systems)	Natural	500 ea
DXHH20	8 oz Rectangular Soup Bowl, 4.75" x 3.5"	Natural	1,000 ea
DXHH20A	8 oz Rectangular Soup Bowl, 4.75" x 3.5" (for Aladdin TempRite II)	Natural	1,000 ea
DXHH27B	6 oz Round Soup Bowl (Substitute for Aladdin B27)	Natural	1,000 ea
DXHH30	Rectangular Soup Bowl Lid (fits DXHH20, DXHH20A)	Natural	1,000 ea
DXHH87	Round Soup Bowl Lid (fits DXHH27B)	Natural	1,000 ea
DXHH1	6 oz Side Dish, 5.25" x 4"	Natural	2,000 ea
DXHH8	12 oz Rectangular Entrée Dish, 7.5" x 5.25"	Natural	1,000 ea
DXHH10	7.75" Entree Plate	03	500 ea
DXHHPL7	7.75" Wide Rim Entree Plate	03	500 ea
DXHHD7	7.75" Dome Plate Cover, Fits DXHH10 and DXHHPL7	03	500 ea

Note: Aladdin, Excel & TempRite II are registered trademarks of Aladdin® Corporation. Kendrick Johnson® is a registered name.



DISPOSABLE LIDS

Each of our wares has a **customized disposable lid** that is designed to fit the top **perfectly** – not too tight so it is hard to remove and not too loose to allow liquids to spill.



Dinex disposable lids are manufactured in an NSF certified GMP facility. This assures the products you are using were manufactured in an environment that is contamination and pest free.

- Dinex offers a **wide assortment** of single-use, disposable lids to fit Dinex, as well as a number of other manufacturers' products, including Aladdin® (Traditional, Allure), Cambro®, Carlisle® FoodService, Degree®, Keepers® (Seco Systems), Libbey® and many others
- Manufactured from **sturdy, high density material**
- Several popular styles feature stacking lugs and removal tabs to allow for easy separation
- Lid fit may vary if the lid is not manufactured by Dinex, so using a **Dinex lid** with **Dinex wares** will ensure patient **satisfaction** and **comfort**
- **Hot food lids are vented for safety**

Dinex® Generic Disposable Lids

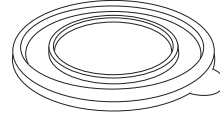

DXTT59



DX11988714

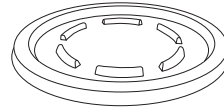

DX22259000

High-Temp Disposable Lid



DXHHSCM/DXHHSCS

Prod No	Description	Fit	Pack
Dinex Generic Healthcare Disposable Lids			
DXTT39	Translucent Lid	Tradition 8 oz Insul Bowls DX4B/GET 2224, 2232, 6632	1,000 ea
DXTT59	Translucent Lid	Tradition 8 oz Insul Mugs DX4M & 5 oz Bowl DX4C/Carlisle 43649/Cambo D16/GET 6612,8812, 9910	2,000 ea
DX11968714	Translucent Lid	DX4GC6, DX4GC8/Carlisle 5108, 5806/Cambo NT8, 800CW, 800P/GET 2206	1,000 ea
DX1196ST8714	Translucent Lid w/Straw Slot	DX4GC6, DX4GC8/Carlisle 5108, 5806/Cambo NT8, 800CW, 800P/GET 2206	1,000 ea
DX11988714	Translucent Lid	DX5506, Carlisle 4408, 4031, 5109, 5506, 5512/Cambo 950CP/GET 8810	1,000 ea
DX1198ST8714	Translucent Lid w/Straw Slot	DX5506, Carlisle 4408, 4031, 5109, 5506, 5512/Cambo 950CP/GET 8810	1,000 ea
DX11998714	Translucent Lid	Keepers 8 oz Insul Mug & 5 oz Bowl	2,000 ea
DX20019000	Translucent Lid	Cambo NT5	1,500 ea
DX20029000	Translucent Lid	Carlisle 43633, 423633/Cambo HT8CW, NT8/GET 2206, 6608	1,500 ea
DX2002ST9000	Translucent Lid w/Straw Slot	Carlisle 43633, 423633/Cambo HT8CW, NT8/GET 2206, 6608	1,500 ea
DX21259000	Translucent Lid	Aladdin 8 oz Insul Mug, 5 oz Bowl & 8-12 oz Tumblers	2,000 ea
DX2125ST9000	Translucent Lid w/Straw Slot	Aladdin 8 oz Insul Mug, 5 oz Bowl & 8-12 oz Tumblers	2,000 ea
DX21359000	Translucent Lid	Aladdin 8 oz Insul Bowl & 8/10 oz Clear Bowls	1,000 ea
DX22259000	Translucent Lid	Carlisle 4012, 43636, 5808/ Cambro NT9, NT16/ GET 9907, 9909	2,000 ea
DX2225ST9000	Translucent Lid w/Straw Slot	Carlisle 4012, 43636, 5808/ Cambro NT9, NT16/ GET 9907, 9909	2,000 ea
DX24019000	Translucent Lid	Carlisle 43632, 5505/ Cambro HT5CW	1,500 ea
DX11928714	Translucent Lid	DX1192, Carlisle 5105/Cambo 500CW, 500P/GET 6605	1000 ea
DX1193ST8714	Translucent Lid w/Straw Slot	DX5501/Carlisle 5105, 5501	1000 ea
DXTT58	Translucent Lid w/Straw Slot	DX4GC, DX4GC9, DX4GC12, DX5529/Carlisle 4016, 4034, 5216, 5529, 5810/Cambo D14, HT14CW, LT14/GET 2209, 2211, 6609, 9909	1000 ea
DX11838714	Translucent Lid	Classic 8 oz bowl DX1187	1000 ea
High-Temp Lids			
DXHHSCM	High Heat White Lid	Aladdin High Heat 8 oz Mug/KJ High Heat 8 oz Mug & 5 oz Bowl	2,000 ea
DXHHSCS	High Heat White Lid	Aladdin High Heat 5 oz & 8 oz Bowls/KJ High Heat 8 oz & 12 oz Bowls	1,000 ea
Classic Lids			
DX11948700	Clear-view Flat Lid	DX1197, DX1105	2,000 ea
DX11948714	Translucent Lid	DX1197, DX1105	2,000 ea
DX11858700	Clear-view Flat Lid	DX1185	1,000 ea
DX11858714	Translucent Lid	DX1185	—
DX11868714	Translucent Lid	DX1186	1,000 ea

Lid fit may vary on non-Dinex products due to changes in manufacturing specifications.

Dinex is not associated in any way with Aladdin, Cambro, Degree, Keepers, Newport, Sysco, and/or Kendrick Johnson.

Note: Cambro, Carlisle, Degree, Keepers, Newport, and Sysco are registered trademarks.

Note: Aladdin, Excel & TempRite II are registered trademarks of Aladdin® Corporation. Kendrick Johnson® is a registered name.

GLASSWARE COVERS

ProCap® Glassware Covers

- **Attractive alternative to paper glassware covers, and plastic wrap**
- Finest universal capping system available on the market today
- Use as a dust cover for in-room glassware or as a lid for beverage delivery
- Every clear ProCap lid fits a variety of glassware and container sizes—as small as 1.88" to 5" (outside diameter)



Dinex disposable lids are manufactured in an NSF certified GMP facility. This assures the products you are using were manufactured in an environment that is contamination and pest free.

Prod No	Description	Pack
ProCap Lids		
DX45-47 †	Clear- View Lid, Fits range 45-47 millimeter glass diameter	3,000 ea
DX47-49 †	Clear- View Lid, Fits range 47-49 millimeter glass diameter	3,000 ea
DX49-51 †	Clear- View Lid, Fits range 49-51 millimeter glass diameter	3,000 ea
DX51-53 †	Clear- View Lid, Fits range 51-53 millimeter glass diameter	3,000 ea
DX53-55 †	Clear- View Lid, Fits range 53-55 millimeter glass diameter	3,000 ea
DX55-57 †	Clear- View Lid, Fits range 55-57 millimeter glass diameter	3,000 ea
DX57-59	Clear- View Lid, Fits range 57-59 millimeter glass diameter	3,000 ea
DX59-61	Clear- View Lid, Fits range 59-61 millimeter glass diameter	3,000 ea
DX61-63	Clear- View Lid, Fits range 61-63 millimeter glass diameter	2,000 ea
DX63-65	Clear- View Lid, Fits range 63-65 millimeter glass diameter	2,000 ea
DX65-67	Clear- View Lid, Fits range 65-67 millimeter glass diameter	2,000 ea
DX67-69	Clear- View Lid, Fits range 67-69 millimeter glass diameter	2,000 ea
DX69-71	Clear- View Lid, Fits range 69-71 millimeter glass diameter	2,000 ea
DX71-73	Clear- View Lid, Fits range 71-73 millimeter glass diameter	2,000 ea
DX73-75	Clear- View Lid, Fits range 73-75 millimeter glass diameter	2,000 ea
DX75-77	Clear- View Lid, Fits range 75-77 millimeter glass diameter	2,000 ea
DX77-79	Clear- View Lid, Fits range 77-79 millimeter glass diameter	2,000 ea
DX79-81	Clear- View Lid, Fits range 79-81 millimeter glass diameter	2,000 ea
DX81-83	Clear- View Lid, Fits range 81-83 millimeter glass diameter	2,000 ea
DX83-85	Clear- View Lid, Fits range 83-85 millimeter glass diameter	2,000 ea
DX85-87	Clear- View Lid, Fits range 85-87 millimeter glass diameter	2,000 ea
DX87-89	Clear- View Lid, Fits range 87-89 millimeter glass diameter	2,000 ea
DX89-91	Clear- View Lid, Fits range 89-91 millimeter glass diameter	1,000 ea
DX91-93	Clear- View Lid, Fits range 91-93 millimeter glass diameter	1,000 ea
DX93-95	Clear- View Lid, Fits range 93-95 millimeter glass diameter	1,000 ea
DX95-97	Clear- View Lid, Fits range 95-97 millimeter glass diameter	1,000 ea
DX97-99 †	Clear- View Lid, Fits range 97-99 millimeter glass diameter	1,000 ea
DX99-101 †	Clear- View Lid, Fits range 99-101 millimeter glass diameter	1,000 ea
DX101-103 †	Clear- View Lid, Fits range 101-103 millimeter glass diameter	1,000 ea
DX103-105 †	Clear- View Lid, Fits range 103-105 millimeter glass diameter	1,000 ea
DX105-107 †	Clear- View Lid, Fits range 105-107 millimeter glass diameter	1,000 ea
DX107-109 †	Clear- View Lid, Fits range 107-109 millimeter glass diameter	1,000 ea
DX109-111 †	Clear- View Lid, Fits range 109-111 millimeter glass diameter	1,000 ea
DX111-113 †	Clear- View Lid, Fits range 111-113 millimeter glass diameter	1,000 ea
DX113-115 †	Clear- View Lid, Fits range 113-115 millimeter glass diameter	1,000 ea
DX115-117 †	Clear- View Lid, Fits range 115-117 millimeter glass diameter	1,000 ea
DX117-119 †	Clear- View Lid, Fits range 117-119 millimeter glass diameter	1,000 ea
DX119-121 †	Clear- View Lid, Fits range 119-121 millimeter glass diameter	1,000 ea
DX121-123 †	Clear- View Lid, Fits range 121-123 millimeter glass diameter	1,000 ea
Clear-View® Dome Lids		
DX101-103DM †	Clear- View Lid, Fits range 101-103 millimeter glass diameter	1,000 ea
DX121-123DM †	Clear- View Lid, Fits range 121-123 millimeter glass diameter	1,000 ea

† Indicates a 50 case minimum order requirement. Please allow 3-4 weeks for production.





PROEX DISPOSABLE FOOD CONTAINERS

Proex offers Custom and Stock Food Packaging for Hospitals Cafeterias, Schools and Prisons.

- Variety of shapes designed to serve, reheat and store hot or cold to-go food
- Available in rectangular, square, oval and round shapes from 8 oz to 32 oz for individual servings or family portions
- Reheat in containers; polypropylene containers will withstand food temperatures up to 280°F under heat lamps, in warming units/tunnels or in microwave
- Containers are made with natural additives, reducing the use of plastic resins by 45%
- Merchandise chilled or frozen foods in attractive black polypropylene containers
- Clear lid will withstand temperature up to 150°F
- Sure-Seal lids are designed to stack securely on display
- Polypropylene containers are top rack dishwasher safe providing consumer convenient re-usability
- Container and lid are recyclable

NOTE: Remove lids before microwaving or heating

Custom Capabilities

Whether you are in need of one of our standard products or custom packaging, Proex can design a solution to fit your needs.



Dinex disposable lids are manufactured in an NSF certified GMP facility. This assures the products you are using were manufactured in an environment that is contamination and pest free.



DXMW810BLK



DXMW810BLK and DXL800PDCLR



DXMW813BLK



DXMW812BLK and DXL800PDCLR

Prod No	Description	Capacity	Pack
Microwavable Entrée Containers & Lids			
DXMW4016PBLK	Medium Entrée – Black Microwaveable	16 oz	250 ea
DXMW4024PBLK	Medium Entrée – Black Microwaveable	24 oz	250 ea
DXMW4032PBLK	Medium Entrée – Black Microwaveable	32 oz	250 ea
DXL4000PCLR	Clear Flat Lid – Fits Medium Entrée Container	—	250 ea
DXL4000PDCLR	Clear Dome Lid – Fits Medium Entrée Container	—	250 ea
DXMW810PBLK	One Compartment Large Entrée – Black Microwaveable	32 oz	250 ea
DXMW812PBLK	Two Compartment Large Entrée – Black Microwaveable	18/10 oz	250 ea
DXMW813PBLK	Three Compartment Large Entrée – Black Microwaveable	18/4/4 oz	250 ea
DXL800PCLR	Clear Flat Lid – Fits Large Entrée Containers	—	250 ea
DXL800PDCLR	Clear Dome Lid – Fits Large Entrée Containers	—	250 ea
Microwavable Oval Casserole Containers & Lids			
DXMW912PBLK	Casserole Dish – Black Microwaveable	12 oz	250 ea
DXMW916PBLK	Casserole Dish – Black Microwaveable	16 oz	250 ea
DXL900PDCLR	Clear Dome Lid – Fits Casserole Containers	—	250 ea

*Natural Polypropylene available for many items as custom run



DXMW512BLK
and DXL500PDCLR



DXMW5401BLK
and DXL5400PDCLR



DXMW5401BLK
and DXL5400PCLR

Prod No	Description	Capacity	Pack
Round Microwavable Container, Salad Bowl & Lids			
DXMW5401PBLK	Round 7.25" – Black Microwavable	20 oz	300 ea
DX5402PCLR	Salad/Dessert Bowl – Clear	24 oz	300 ea
DXT5400PCLR	Flat Insert for Round Container or Bowl		300 ea
DXT5400PDCLR	Dome Insert for Round Container or Bowl		300 ea
DXL5400PCLR	Clear Flat Lid – Fits Round Container or Bowl	—	300 ea
DXL5400PDCLR	Clear Dome Lid – Fits Round Container or Bowl	—	300 ea
Microwavable Square Side Dish Containers & Lids			
DXMW508PBLK	Square Container – Black Microwavable	8 oz	500 ea
DXMW512PBLK	Square Container – Black Microwavable	12 oz	500 ea
DXMW516PBLK	Square Container – Black Microwavable	16 oz	500 ea
DXL500PCLR	Clear Flat Lid – Fits Square Side Dish Container	—	500 ea
DXL500PDCLR	Clear Dome Lid – Fits Square Side Dish Container	—	500 ea
DXMW201PBLK	Soufflé Dish – Black Microwavable	8 oz	300 ea
DXL200PCLR	Clear Flat Lid – Fits DXMW201PBLK	—	300 ea
Microwavable Trays – Heat Seal Flange			
DXMW5501PBLK	3 Compartment Lunch Tray – Black Microwavable	32 oz	300 ea
DXMW5501PNAT	3 Compartment Lunch Tray – Natural Microwavable	32 oz	300 ea
DX2502POPQ	3 Compartment Snack Tray – Opaque	6/4/4 oz	450 ea

*Natural Polypropylene available for many items as custom run



DINEX

ELEGANT
FUNCTIONAL
DURABLE
FINISHING-
TOUCH
**DISHWARE &
DISPOSABLE**

*Dinex is your complete source for trayservice.
Offering a collection of contemporary styled
china, disposable dishware and a large selection
of disposable lids designed to fit a variety of
insulated ware, bowls and tumblers.*





DINEX DINNERWARE

Dinex offers a wide range of dishware and disposable options. Paramount to our designs is the comfort and **satisfaction of your patients**. From **elegant** temperature-retaining china to **quality** cost-saving **disposables**, Dinex has the selection to fit the strictest food preparation requirements.

Narrow Rim Embossed China Dishware

- **Elegant Bright White** china featuring a narrow embossed rim
- Compatible with Dinex bases
- Dishwasher safe

Dinex® Wide Rim China Dishware

- **Elegant Bright White** china featuring a wide rim
- Compatible with Dinex bases
- Dishwasher safe

China Accessories

- **Fenwick disposable lids** in clear or translucent cover mugs and bowls for transport
- Casserole dishes in 6 oz or 10 oz fit on an entrée plate underneath an insulated dome cover



Disposable dome lid for fruit bowl and bread plate DX11880174



Prod No	Description	Color	Pack
Narrow Rim Embossed China Dishware			
DX5CBPB	5.5" Bread & Dessert Plate	02	36 ea
DX5CFNB	5.75 oz Fruit Bowl	02	36 ea
DX9CP	9" Entrée Plate	02	12 ea
Dinex Wide Rim China Dishware — Bright White			
DX5ACBP	5.5" China Plate	02A	36 ea
DX9ACP	9" China Plate	02A	24 ea
China Accessories			
DXHHC10	7.75" Entrée Plate	02	24 ea
DX6CASS	6 oz China Casserole	02A	36 ea
DX10CASS	10 oz China Casserole	02A	
DX11880174*	Disposable Clear Dome Lid for China Bread Plate & Fruit Bowl (fits DX5CBPB, DX5CFNB & DX5ACBP)	—	500 ea

*Disposable lids for china are not leak proof



Melamine Plate

- Attractive, **high quality melamine** dishware provides a safe and durable alternative to china
- Not recommended for use in microwave or plate heater
- Dishwasher safe



Disposable Dishware & Lids

- Manufactured and stored in the **strictest of sanitary conditions** to assure you receive pest and contamination free products
- The most sanitary disposables in the healthcare industry



High-Heat Disposable Dishware & Lids

- DineX high heat disposables are microwavable and can be used in retherm or other heated cart systems. They feature a natural color and are made with natural additives, reducing the use of plastic by 45%

Note: High-Heat Disposable Dishware is not safe to heat over 300°F

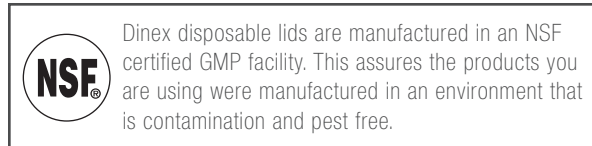

New high heat 7.75" narrow or wide rim plate and dome cover in black



Prod No	Description	Color	Pack
Melamine Plate			
DX4T9	9" Entrée Plate	02	24 ea
Disposable Dishware			
DXTT1	6 oz Side Dish, 5.25" x 4"	White	2,000 ea
DXTT6	4 oz Dessert Dish, 4" x 3.5"	White	4,000 ea
DXTT8	12 oz Rectangular Entrée Dish, 7.5" x 5.25"	White	1,000 ea
DXTT20	8 oz Rectangular Soup Bowl, 4.75" x 3.5"	White	1,000 ea
DXTT30	Rectangular Soup Bowl Lid (fits DXTT20), 4.75" x 3.5"	Translucent	1,000 ea
High-Heat Disposable Dishware			
DXHH10	7.75" Entrée, One Compartment	Natural	500 ea
DXHH10A	7.75" Entrée, One Compartment (for Aladdin Excel Systems)	Natural	500 ea
DXHH20	8 oz Rectangular Soup Bowl, 4.75" x 3.5"	Natural	1,000 ea
DXHH20A	8 oz Rectangular Soup Bowl, 4.75" x 3.5" (for Aladdin TempRite II)	Natural	1,000 ea
DXHH27B	6 oz Round Soup Bowl (Substitute for Aladdin B27)	Natural	1,000 ea
DXHH30	Rectangular Soup Bowl Lid (fits DXHH20, DXHH20A)	Natural	1,000 ea
DXHH87	Round Soup Bowl Lid (fits DXHH27B)	Natural	1,000 ea
DXHH1	6 oz Side Dish, 5.25" x 4"	Natural	2,000 ea
DXHH8	12 oz Rectangular Entrée Dish, 7.5" x 5.25"	Natural	1,000 ea
DXHH10	7.75" Entree Plate	03	500 ea
DXHHPL7	7.75" Wide Rim Entree Plate	03	500 ea
DXHHD7	7.75" Dome Plate Cover, Fits DXHH10 and DXHHPL7	03	500 ea

Note: Aladdin, Excel & TempRite II are registered trademarks of Aladdin Corporation. Kendrick Johnson® is a registered name.



DISPOSABLE LIDS

Each of our wares has a **customized disposable lid** that is designed to fit the top **perfectly** – not too tight so it is hard to remove and not too loose to allow liquids to spill.



Dinex disposable lids are manufactured in an NSF certified GMP facility. This assures the products you are using were manufactured in an environment that is contamination and pest free.

- Dinex offers a **wide assortment** of single-use, disposable lids to fit Dinex, as well as a number of other manufacturers' products, including Aladdin® (Traditional, Allure), Cambro®, Carlisle® FoodService, Degree®, Keepers® (Seco Systems), Libbey® and many others
- Manufactured from **sturdy, high density material**
- Several popular styles feature stacking lugs and removal tabs to allow for easy separation
- Lid fit may vary if the lid is not manufactured by Dinex, so using a **Dinex lid** with **Dinex wares** will ensure patient **satisfaction** and **comfort**
- **Hot food lids are vented for safety**

Dinex® Generic Disposable Lids

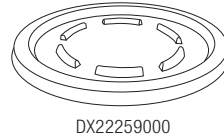
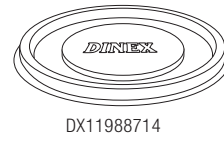
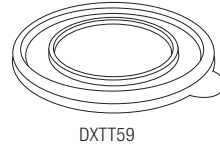

High-Temp Disposable Lid



Prod No	Description	Fit	Pack
Dinex Generic Healthcare Disposable Lids			
DXTT39	Translucent Lid	Tradition 8 oz Insul Bowls DX4B/GET 2224, 2232, 6632	1,000 ea
DXTT59	Translucent Lid	Tradition 8 oz Insul Mugs DX4M & 5 oz Bowl DX4C/Carlisle 43649/Cambo D16/GET 6612,8812, 9910	2,000 ea
DX11968714	Translucent Lid	DX4GC6, DX4GC8/Carlisle 5108, 5806/Cambo NT8, 800CW, 800P/GET 2206	1,000 ea
DX1196ST8714	Translucent Lid w/Straw Slot	DX4GC6, DX4GC8/Carlisle 5108, 5806/Cambo NT8, 800CW, 800P/GET 2206	1,000 ea
DX11988714	Translucent Lid	DX5506, Carlisle 4408, 4031, 5109, 5506, 5512/Cambo 950CP/GET 8810	1,000 ea
DX1198ST8714	Translucent Lid w/Straw Slot	DX5506, Carlisle 4408, 4031, 5109, 5506, 5512/Cambo 950CP/GET 8810	1,000 ea
DX11998714	Translucent Lid	Keepers 8 oz Insul Mug & 5 oz Bowl	2,000 ea
DX20019000	Translucent Lid	Cambo NT5	1,500 ea
DX20029000	Translucent Lid	Carlisle 43633, 423633/Cambo HT8CW, NT8/GET 2206, 6608	1,500 ea
DX2002ST9000	Translucent Lid w/Straw Slot	Carlisle 43633, 423633/Cambo HT8CW, NT8/GET 2206, 6608	1,500 ea
DX21259000	Translucent Lid	Aladdin 8 oz Insul Mug, 5 oz Bowl & 8-12 oz Tumblers	2,000 ea
DX2125ST9000	Translucent Lid w/Straw Slot	Aladdin 8 oz Insul Mug, 5 oz Bowl & 8-12 oz Tumblers	2,000 ea
DX21359000	Translucent Lid	Aladdin 8 oz Insul Bowl & 8/10 oz Clear Bowls	1,000 ea
DX22259000	Translucent Lid	Carlisle 4012, 43636, 5808/ Cambro NT9, NT16/ GET 9907, 9909	2,000 ea
DX2225ST9000	Translucent Lid w/Straw Slot	Carlisle 4012, 43636, 5808/ Cambro NT9, NT16/ GET 9907, 9909	2,000 ea
DX24019000	Translucent Lid	Carlisle 43632, 5505/ Cambro HT5CW	1,500 ea
DX11928714	Translucent Lid	DX1192, Carlisle 5105/Cambo 500CW, 500P/GET 6605	1000 ea
DX1193ST8714	Translucent Lid w/Straw Slot	DX5501/Carlisle 5105, 5501	1000 ea
DXTT58	Translucent Lid w/Straw Slot	DX4GC, DX4GC9, DX4GC12, DX5529/Carlisle 4016, 4034, 5216, 5529, 5810/Cambo D14, HT14CW, LT14/GET 2209, 2211, 6609, 9909	1000 ea
DX11838714	Translucent Lid	Classic 8 oz bowl DX1187	1000 ea
High-Temp Lids			
DXHHSCM	High Heat White Lid	Aladdin High Heat 8 oz Mug/KJ High Heat 8 oz Mug & 5 oz Bowl	2,000 ea
DXHHSCS	High Heat White Lid	Aladdin High Heat 5 oz & 8 oz Bowls/KJ High Heat 8 oz & 12 oz Bowls	1,000 ea
Classic Lids			
DX11948700	Clear-view Flat Lid	DX1197, DX1105	2,000 ea
DX11948714	Translucent Lid	DX1197, DX1105	2,000 ea
DX11858700	Clear-view Flat Lid	DX1185	1,000 ea
DX11858714	Translucent Lid	DX1185	—
DX11868714	Translucent Lid	DX1186	1,000 ea

Lid fit may vary on non-Dinex products due to changes in manufacturing specifications.

Dinex is not associated in any way with Aladdin, Cambro, Degree, Keepers, Newport, Sysco, and/or Kendrick Johnson.

Note: Cambro, Carlisle, Degree, Keepers, Newport, and Sysco are registered trademarks.

Note: Aladdin, Excel & TempRite II are registered trademarks of Aladdin® Corporation. Kendrick Johnson® is a registered name.

GLASSWARE COVERS

ProCap® Glassware Covers

- **Attractive alternative to paper glassware covers, and plastic wrap**
- Finest universal capping system available on the market today
- Use as a dust cover for in-room glassware or as a lid for beverage delivery
- Every clear ProCap lid fits a variety of glassware and container sizes—as small as 1.88" to 5" (outside diameter)



Dinex disposable lids are manufactured in an NSF certified GMP facility. This assures the products you are using were manufactured in an environment that is contamination and pest free.

Prod No	Description	Pack
ProCap Lids		
DX45-47 †	Clear- View Lid, Fits range 45-47 millimeter glass diameter	3,000 ea
DX47-49 †	Clear- View Lid, Fits range 47-49 millimeter glass diameter	3,000 ea
DX49-51 †	Clear- View Lid, Fits range 49-51 millimeter glass diameter	3,000 ea
DX51-53 †	Clear- View Lid, Fits range 51-53 millimeter glass diameter	3,000 ea
DX53-55 †	Clear- View Lid, Fits range 53-55 millimeter glass diameter	3,000 ea
DX55-57 †	Clear- View Lid, Fits range 55-57 millimeter glass diameter	3,000 ea
DX57-59	Clear- View Lid, Fits range 57-59 millimeter glass diameter	3,000 ea
DX59-61	Clear- View Lid, Fits range 59-61 millimeter glass diameter	3,000 ea
DX61-63	Clear- View Lid, Fits range 61-63 millimeter glass diameter	2,000 ea
DX63-65	Clear- View Lid, Fits range 63-65 millimeter glass diameter	2,000 ea
DX65-67	Clear- View Lid, Fits range 65-67 millimeter glass diameter	2,000 ea
DX67-69	Clear- View Lid, Fits range 67-69 millimeter glass diameter	2,000 ea
DX69-71	Clear- View Lid, Fits range 69-71 millimeter glass diameter	2,000 ea
DX71-73	Clear- View Lid, Fits range 71-73 millimeter glass diameter	2,000 ea
DX73-75	Clear- View Lid, Fits range 73-75 millimeter glass diameter	2,000 ea
DX75-77	Clear- View Lid, Fits range 75-77 millimeter glass diameter	2,000 ea
DX77-79	Clear- View Lid, Fits range 77-79 millimeter glass diameter	2,000 ea
DX79-81	Clear- View Lid, Fits range 79-81 millimeter glass diameter	2,000 ea
DX81-83	Clear- View Lid, Fits range 81-83 millimeter glass diameter	2,000 ea
DX83-85	Clear- View Lid, Fits range 83-85 millimeter glass diameter	2,000 ea
DX85-87	Clear- View Lid, Fits range 85-87 millimeter glass diameter	2,000 ea
DX87-89	Clear- View Lid, Fits range 87-89 millimeter glass diameter	2,000 ea
DX89-91	Clear- View Lid, Fits range 89-91 millimeter glass diameter	1,000 ea
DX91-93	Clear- View Lid, Fits range 91-93 millimeter glass diameter	1,000 ea
DX93-95	Clear- View Lid, Fits range 93-95 millimeter glass diameter	1,000 ea
DX95-97	Clear- View Lid, Fits range 95-97 millimeter glass diameter	1,000 ea
DX97-99 †	Clear- View Lid, Fits range 97-99 millimeter glass diameter	1,000 ea
DX99-101 †	Clear- View Lid, Fits range 99-101 millimeter glass diameter	1,000 ea
DX101-103 †	Clear- View Lid, Fits range 101-103 millimeter glass diameter	1,000 ea
DX103-105 †	Clear- View Lid, Fits range 103-105 millimeter glass diameter	1,000 ea
DX105-107 †	Clear- View Lid, Fits range 105-107 millimeter glass diameter	1,000 ea
DX107-109 †	Clear- View Lid, Fits range 107-109 millimeter glass diameter	1,000 ea
DX109-111 †	Clear- View Lid, Fits range 109-111 millimeter glass diameter	1,000 ea
DX111-113 †	Clear- View Lid, Fits range 111-113 millimeter glass diameter	1,000 ea
DX113-115 †	Clear- View Lid, Fits range 113-115 millimeter glass diameter	1,000 ea
DX115-117 †	Clear- View Lid, Fits range 115-117 millimeter glass diameter	1,000 ea
DX117-119 †	Clear- View Lid, Fits range 117-119 millimeter glass diameter	1,000 ea
DX119-121 †	Clear- View Lid, Fits range 119-121 millimeter glass diameter	1,000 ea
DX121-123 †	Clear- View Lid, Fits range 121-123 millimeter glass diameter	1,000 ea
Clear-View® Dome Lids		
DX101-103DM †	Clear- View Lid, Fits range 101-103 millimeter glass diameter	1,000 ea
DX121-123DM †	Clear- View Lid, Fits range 121-123 millimeter glass diameter	1,000 ea

† Indicates a 50 case minimum order requirement. Please allow 3-4 weeks for production.



PROEX DISPOSABLE FOOD CONTAINERS

Proex offers Custom and Stock Food Packaging for Hospitals Cafeterias, Schools and Prisons.

- Variety of shapes designed to serve, reheat and store hot or cold to-go food
- Available in rectangular, square, oval and round shapes from 8 oz to 32 oz for individual servings or family portions
- Reheat in containers; polypropylene containers will withstand food temperatures up to 280°F under heat lamps, in warming units/tunnels or in microwave
- Containers are made with natural additives, reducing the use of plastic resins by 45%
- Merchandise chilled or frozen foods in attractive black polypropylene containers
- Clear lid will withstand temperature up to 150°F
- Sure-Seal lids are designed to stack securely on display
- Polypropylene containers are top rack dishwasher safe providing consumer convenient re-usability
- Container and lid are recyclable

NOTE: Remove lids before microwaving or heating

Custom Capabilities

Whether you are in need of one of our standard products or custom packaging, Proex can design a solution to fit your needs.



Dinex disposable lids are manufactured in an NSF certified GMP facility. This assures the products you are using were manufactured in an environment that is contamination and pest free.



DXMW810BLK



DXMW810BLK and DXL800PDCLR



DXMW813BLK



DXMW812BLK and DXL800PDCLR

Prod No	Description	Capacity	Pack
Microwavable Entrée Containers & Lids			
DXMW4016PBLK	Medium Entrée – Black Microwaveable	16 oz	250 ea
DXMW4024PBLK	Medium Entrée – Black Microwaveable	24 oz	250 ea
DXMW4032PBLK	Medium Entrée – Black Microwaveable	32 oz	250 ea
DXL4000PCLR	Clear Flat Lid – Fits Medium Entrée Container	—	250 ea
DXL4000PDCLR	Clear Dome Lid – Fits Medium Entrée Container	—	250 ea
DXMW810PBLK	One Compartment Large Entrée – Black Microwaveable	32 oz	250 ea
DXMW812PBLK	Two Compartment Large Entrée – Black Microwaveable	18/10 oz	250 ea
DXMW813PBLK	Three Compartment Large Entrée – Black Microwaveable	18/4/4 oz	250 ea
DXL800PCLR	Clear Flat Lid – Fits Large Entrée Containers	—	250 ea
DXL800PDCLR	Clear Dome Lid – Fits Large Entrée Containers	—	250 ea
Microwavable Oval Casserole Containers & Lids			
DXMW912PBLK	Casserole Dish – Black Microwaveable	12 oz	250 ea
DXMW916PBLK	Casserole Dish – Black Microwaveable	16 oz	250 ea
DXL900PDCLR	Clear Dome Lid – Fits Casserole Containers	—	250 ea

*Natural Polypropylene available for many items as custom run



DXMW512BLK
and DXL500PDCLR



DXMW5401BLK
and DXL5400PDCLR



DXMW5401BLK
and DXL5400PCLR

Prod No	Description	Capacity	Pack
Round Microwavable Container, Salad Bowl & Lids			
DXMW5401PBLK	Round 7.25" – Black Microwaveable	20 oz	300 ea
DX5402PCLR	Salad/Dessert Bowl – Clear	24 oz	300 ea
DXT5400PCLR	Flat Insert for Round Container or Bowl		300 ea
DXT5400PDCLR	Dome Insert for Round Container or Bowl		300 ea
DXL5400PCLR	Clear Flat Lid – Fits Round Container or Bowl	—	300 ea
DXL5400PDCLR	Clear Dome Lid – Fits Round Container or Bowl	—	300 ea
Microwavable Square Side Dish Containers & Lids			
DXMW508PBLK	Square Container – Black Microwaveable	8 oz	500 ea
DXMW512PBLK	Square Container – Black Microwaveable	12 oz	500 ea
DXMW516PBLK	Square Container – Black Microwaveable	16 oz	500 ea
DXL500PCLR	Clear Flat Lid – Fits Square Side Dish Container	—	500 ea
DXL500PDCLR	Clear Dome Lid – Fits Square Side Dish Container	—	500 ea
DXMW201PBLK	Soufflé Dish – Black Microwaveable	8 oz	300 ea
DXL200PCLR	Clear Flat Lid – Fits DXMW201PBLK	—	300 ea
Microwavable Trays – Heat Seal Flange			
DXMW5501PBLK	3 Compartment Lunch Tray –Black Microwaveable	32 oz	300 ea
DXMW5501PNAT	3 Compartment Lunch Tray – Natural Microwaveable	32 oz	300 ea
DX2502POPQ	3 Compartment Snack Tray – Opaque	6/4/4 oz	450 ea

*Natural Polypropylene available for many items as custom run

Enjoy!



Enjoy!



Bon Appétit



DINEX



CLEAN UPSCALE FESTIVE CUSTOMIZABLE **DECORATOR PAPER PRODUCTS**

Only Dinex decorator paper products coordinate with the color and designs of Dinex insulated wares to create that upscale traytop look that helps increase patient satisfaction. Durable and disposable paper products create a welcome setting for your patient or resident, and help to keep the tray clean and organized during meal delivery.





DECORATOR TRAYCOVERS

With many **designs** available to match your existing decor, Traycovers and Napkins **coordinate** with ware **colors** and complete your traytop for a clean, polished look that helps increase patient satisfaction scores.



Wood
(Full Color)



Woven
(Full Color)

Natural traycovers instantly give your traytop a sophisticated look with a muted, farm-to-table style. Both designs are available in popular 15" x 20" tray size.



Filigree
(Black, Gold)

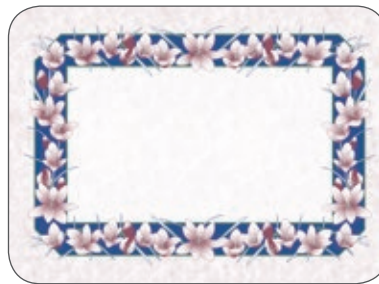

Freesia
(Cranberry, Midnight Blue, Green)



Healthy Diet
(Full Color – Available as Custom Only)



Iris Garden
(Cranberry, Teal, Gray)



Jane's Bouquet
(Cranberry, Midnight Blue, Teal)



Jenny Park
(Full Color)

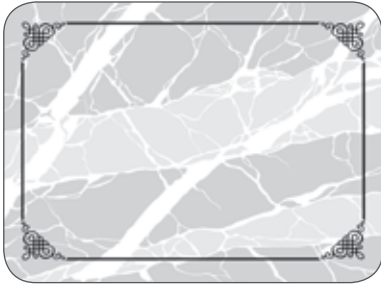

Marbled Elegance
(Black, Gray)



Marbled Elegance II
(Cranberry, Midnight Blue, Gray)



Retro
(Cranberry, Midnight Blue, Plum, Sage, Latte)



Sage Garden
(Full Color)



Vertese
(Midnight Blue, Plum, Sage, Latte)



Watercolors
(Cranberry, Midnight Blue, Green, Mauve, Teal)

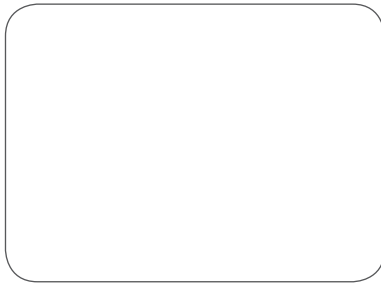

White
(White)



Cranberry
(Solid)



Midnight Blue
(Solid)



Sage
(Solid)

Information on custom traycovers can be found on page 71.



DECORATOR TRAYCOVER SIZES

Traycover Templates

Information on custom traycovers can be found on page 71.

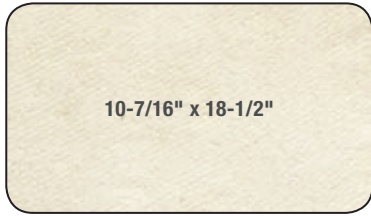

A size
For 12" x 20" Tray

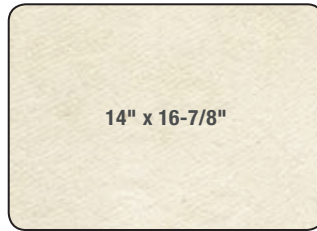

B size - For DXRST1520 Tray

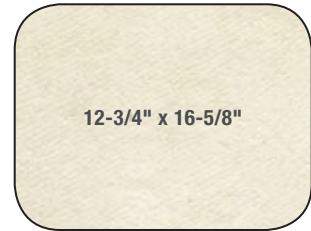

D size & D size (Scalloped)*
9-1/2" x 13-1/2" Placemat

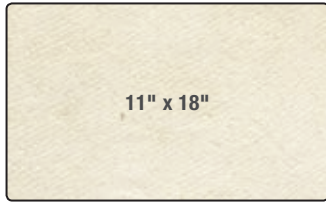

E size
For 12" x 19" Tray

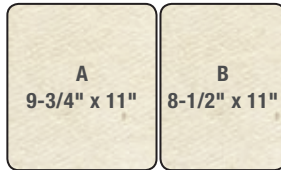

F size - Thermal•Aire
Divided Tray - 2 Piece
DXSC1530152

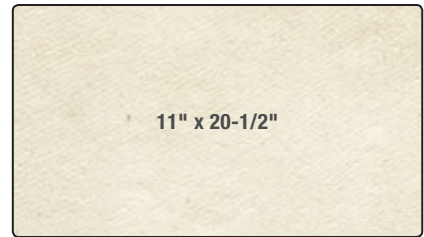

G size
For 12" x 22" Tray

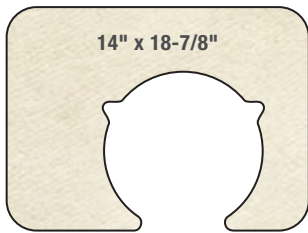

H size - Aladdin
Heat on Demand®

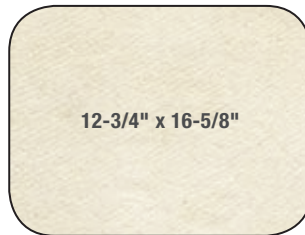

I size & I size (Scalloped)*
For 14" x 18" Tray

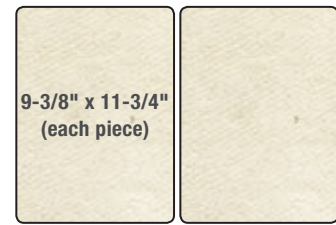

J size
Dinex DX1089MOC23

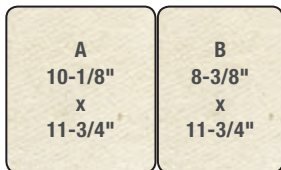

K size - Aladdin
Convect Rite® III

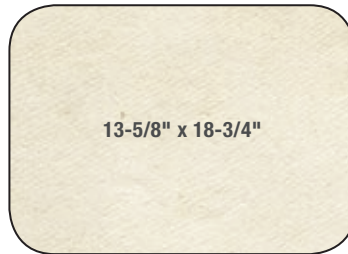

M size & M size (Scalloped)*
For 15" x 20" Tray

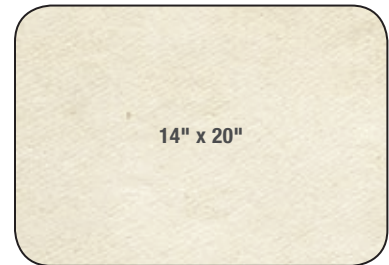

P size & P size (Scalloped)*
For 16" x 22" Tray

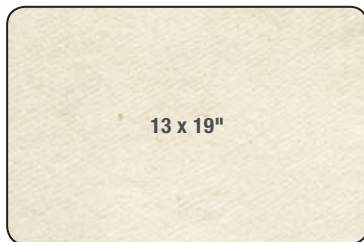

Q size
Fits 15.5" x 21.5" Room Service Trays

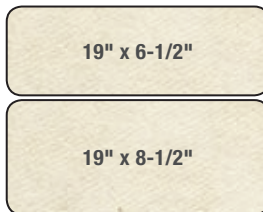

R size
Usecu Unitray

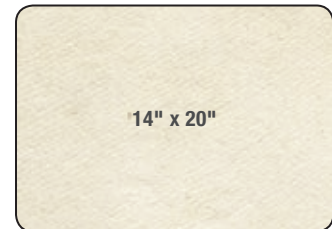

RR size
Dinex DX1089RS152003 & Others

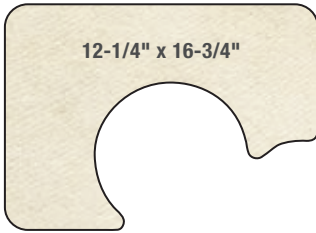

**S size - Aladdin
Temp-Rite II Excel Retherm**

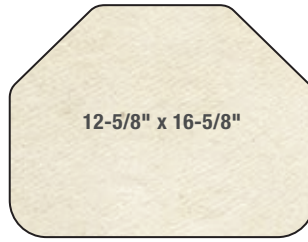

**T size
For 13\"/>**

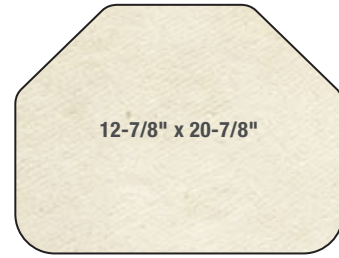

**T size (Large)
For 14\"/>**

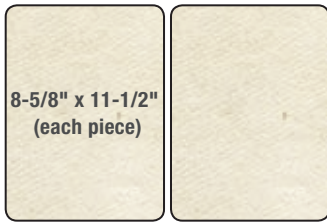

**U size - Useco
Unitron 5 & 7**

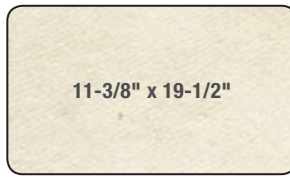

**V size - Thermal•Aire
DXSC1531002**

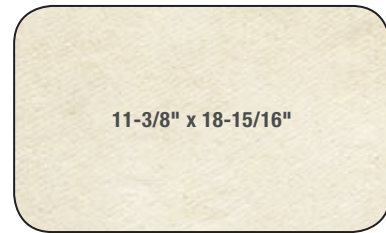

**VV Size - Thermal Aire
Ergonomic
DXSC1321MB**

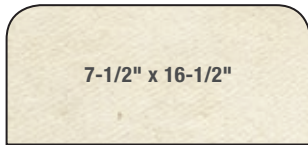

W size - A la Cart

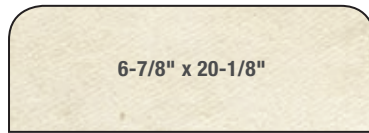

WW size - A la Cart

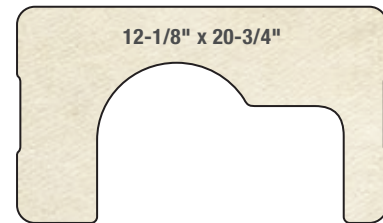

**X size - Perfect•Temp
Classic**

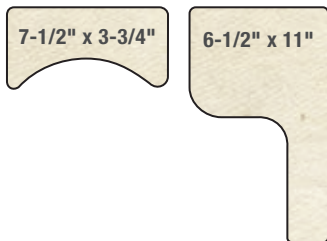

**Z size - Perfect•Temp
Classic II - 2 piece**

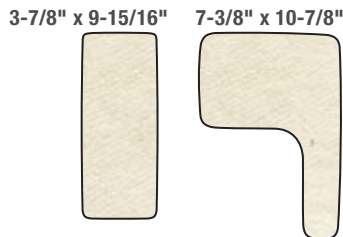

**Aladdin TempRite® II
2 piece**

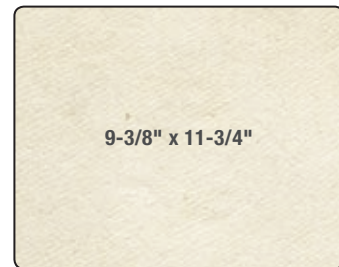

A la Cart Dual-Temp

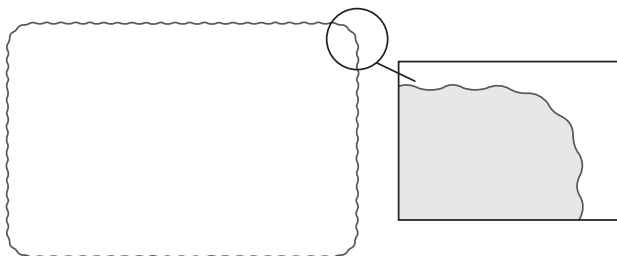

*** Scallop Detail**

Temp-Rite II, Excel, Heat on Demand and Convect Rite III are registered trademarks of Aladdin Temp-Rite, LLC. Unitron and Unitray are trademarks of the Useco Corporation. Dual-Temp is a registered trademark of the A La Cart Corporation.



DECORATOR TRAYCOVER SIZES

Decorator Traycovers are Available in the Following Sizes, Patterns and Quantities.

Information on custom traycovers can be found on page 71.

Not all stock designs are available in every tray size. Contact your Dinx Sales Representative for more information on your specific traycover needs.



Dinx Non-skid traycovers are manufactured without using latex.

Non-Skid Traycovers

Dinx Non-skid traycovers make your operation more efficient by holding dinnerware in place, allowing you to say goodbye to spills and broken items. Dinx Non-skid traycovers come in a variety of healthcare tray sizes and designs that coordinate with Dinx insulated ware. Improve patient scores by delivering a clean, spill-free tray.

TRAYCOVER SIZE: A (10-7/16" x 18-1/2")

DX5081A5	Iris Garden	12" x 20" Tray	Straight Edge/Round Corner	1,000 ea
----------	-------------	----------------	----------------------------	----------

TRAYCOVER SIZE: B (14" x 16-7/8")

Prod No	Description	Application	Style	Pack
DX5350B	Filigree	15" x 20" Roomservice Tray	Straight Edge/Small Corner	1000 ea

TRAYCOVER SIZE: I (12-3/4" x 16-5/8")

Prod No	Description	Application	Style	Pack
DX5055I202833	Jane's Bouquet	14" x 18" Tray	Straight Edge/Round Corner	1,000 ea
DX5081I202733	Iris Garden	14" x 18" Tray	Straight Edge/Round Corner	1,000 ea
DX5320I	Marbled Elegance	14" x 18" Tray	Straight Edge/Round Corner	1,000 ea
DX5323I	Watercolors	14" x 18" Tray	Straight Edge/Round Corner	1,000 ea
DX5331I	Retro	14" x 18" Tray	Straight Edge/Round Corner	1,000 ea
DX5333I	Vertese	14" x 18" Tray	Straight Edge/Round Corner	1,000 ea

Recycled Traycovers

DX5242I	Marisa	14" x 18" Tray	Straight Edge/Round Corner	1,000 ea
DX5243I	Freesia	14" x 18" Tray	Straight Edge/Round Corner	1,000 ea

Solid Color

DX5999I00102	White Embossed	14" x 18" Tray	Scalloped Edge/Round Corner	2,000 ea
--------------	----------------	----------------	-----------------------------	----------

**TRAYCOVER SIZE: J (Two Piece 9-3/8" x 11-3/4" each)**

Prod No	Description	Application	Style	Pack
DX5323J	Watercolors	DX1089MOC23 Tray (Also Fits A la Cart Dual-Temp)	Straight Edge/Round Corner	1,000 ea

TRAYCOVER SIZE: M (13-5/8" x 18-3/4")

Prod No	Description	Application	Style	Pack
DX5055M202833	Jane's Bouquet	15" x 20" Tray	Straight Edge/Round Corner	1,000 ea
DX5091M0000	Jenny Park	15" x 20" Tray	Straight Edge/Round Corner	1,000 ea
DX5081M202733	Iris Garden	15" x 20" Tray	Straight Edge/Round Corner	1,000 ea
DX5243M	Freesia	15" x 20" Tray	Straight Edge/Round Corner	1,000 ea
DX5320M	Marbled Elegance	15" x 20" Tray	Straight Edge/Round Corner	1,000 ea
DX5331M	Retro	15" x 20" Tray	Straight Edge/Round Corner	1,000 ea
DX5333M	Vertese	15" x 20" Tray	Straight Edge/Round Corner	1,000 ea
DX5350M	Filigree	15" x 20" Tray	Straight Edge/Round Corner	1,000 ea
DX5360M	Woven	15" x 20" Tray	Straight Edge/Round Corner	1,000 ea
DX5365M	Wood	15" x 20" Tray	Straight Edge/Round Corner	1,000 ea

Non-Skid Traycovers

DX5081M202733NS	Iris Garden	15" x 20" Tray	Straight Edge/Round Corner	1,000 ea
DX5320MNS	Marbled Elegance	15" x 20" Tray	Straight Edge/Round Corner	1,000 ea

Solid Color

DX5999M00102	White Embossed	15" x 20" Tray	Scalloped Edge/Round Corner	2,000 ea
DX5999MEW02	White Economy	15" x 20" Tray	Straight Edge/Round Corner	2,000 ea
DX5999MEW50	Midnight Blue Economy	15" x 20" Tray	Straight Edge/Round Corner	2,000 ea
DX5999MEW61	Cranberry Economy	15" x 20" Tray	Straight Edge/Round Corner	2,000 ea
DX5999MEW84	Sage Economy	15" x 20" Tray	Straight Edge/Round Corner	2,000 ea

TRAYCOVER SIZE: RR (13-3/8" x 17-7/8")

Prod No	Description	Application	Style	Pack
DX5350RR	Filigree	Dinex DX1089RS1520 & Other 15x20 RS Trays	Straight Edge/Small Corner	1,000 ea

TRAYCOVER SIZE: V (11-3/8" x 19-1/2")

Prod No	Description	Application	Style	Pack
Heavy Weight Bond Traycovers				
DX5322VHW	Marbled Elegance II	Thermal•Aire Flat Tray	Straight Edge/Round Corner	1,000 ea



THE HAPPENINGS HOLIDAY COLLECTION

Most available in convenient 100 each small packs.
Dinex specialty occasion traycovers and napkins
turn your traytop into a festive celebration.

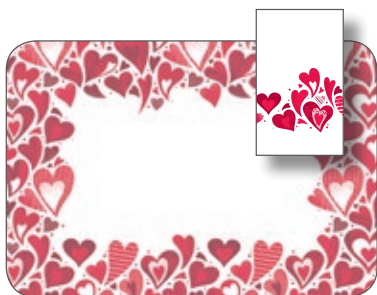

Valentine's Day

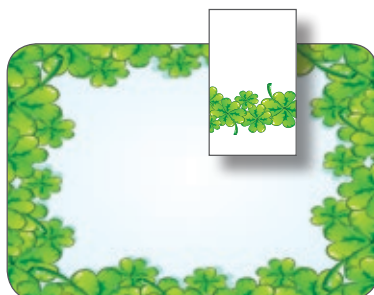

St. Patrick's Day



Happy Easter
(Easter Basket Napkin)



Jack-O-Lanterns



Harvest



Autumn Colors
(Autumn Leaves Napkin)

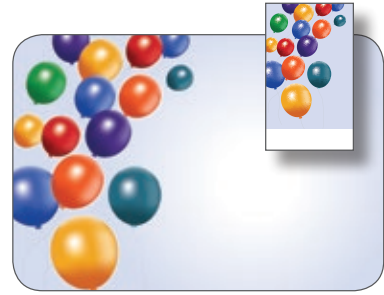

Celebration



Mother's Day Petals
(Happy Mother's Day Napkin)



Stars & Stripes



Father's Day Ties

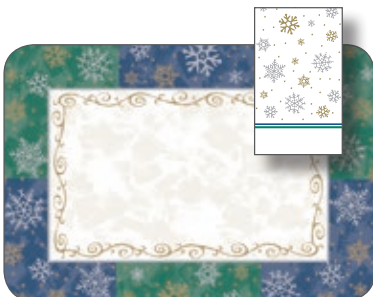

Silver & Gold



Winter Blossom
(Poinsettia Blossom Napkin)



Confetti & Streamers

THE HAPPENINGS HOLIDAY COLLECTION

TRAYCOVER SIZE: I (12-3/4" x 16-5/8")

Prod No	Description	Application	Style	Pack
DXHS325I001	Jack-O-Lanterns	14" x 18" Tray	Straight Edge/Round Corner	100 ea
DXHS345I001	Harvest	14" x 18" Tray	Straight Edge/Round Corner	100 ea
DXHS344I001	Autumn Colors	14" x 18" Tray	Straight Edge/Round Corner	100 ea
DXHS601I001	Stars & Stripes	14" x 18" Tray	Straight Edge/Round Corner	100 ea
DXHR601I001	Stars & Stripes	14" x 18" Tray	Straight Edge/Round Corner	1,000 ea
DXH5455I003	Winter Blossom	14" x 18" Tray	Straight Edge/Round Corner	1,000 ea
DXHS456I001	Silver & Gold	14" x 18" Tray	Straight Edge/Round Corner	100 ea
DXHS470I001	Confetti & Streamers	14" x 18" Tray	Straight Edge/Round Corner	100 ea
DXHS002I001	Valentine's Day	14" x 18" Tray	Straight Edge/Round Corner	100 ea
DXHS052I001	St. Patrick's Day	14" x 18" Tray	Straight Edge/Round Corner	100 ea
DXHS105I001	Happy Easter	14" x 18" Tray	Straight Edge/Round Corner	100 ea
DXHS201I001	Father's Day Ties	14" x 18" Tray	Straight Edge/Round Corner	100 ea
DXHS701I001	Celebration	14" x 18" Tray	Straight Edge/Round Corner	100 ea
DXHS182I001	Mother's Day Petals	14" x 18" Tray	Straight Edge/Round Corner	100 ea

TRAYCOVER SIZE: M (13-5/8" x 18-3/4")

Prod No	Description	Application	Style	Pack
DXHS325M001	Jack-O-Lanterns	15" x 20" Tray	Straight Edge/Round Corner	100 ea
DXHS344M001	Autumn Colors	15" x 20" Tray	Straight Edge/Round Corner	100 ea
DXHS601M001	Stars & Stripes	15" x 20" Tray	Straight Edge/Round Corner	100 ea
DXHR601M001	Stars & Stripes	15" x 20" Tray	Straight Edge/Round Corner	1,000 ea
DXH5455M003	Winter Blossom	15" x 20" Tray	Straight Edge/Round Corner	1,000 ea
DXHS456M001	Silver & Gold	15" x 20" Tray	Straight Edge/Round Corner	100 ea
DXHS470M001	Confetti & Streamers	15" x 20" Tray	Straight Edge/Round Corner	100 ea
DXHS002M001	Valentine's Day	15" x 20" Tray	Straight Edge/Round Corner	100 ea
DXHS052M001	St. Patrick's Day	15" x 20" Tray	Straight Edge/Round Corner	100 ea
DXHS105M001	Happy Easter	15" x 20" Tray	Straight Edge/Round Corner	100 ea
DXHS201M001	Father's Day Ties	15" x 20" Tray	Straight Edge/Round Corner	100 ea
DXHS701M001	Celebration	15" x 20" Tray	Straight Edge/Round Corner	100 ea
DXHS182M001	Mother's Day Petals	15" x 20" Tray	Straight Edge/Round Corner	100 ea



**NAPKIN SIZE: DINNER (15" x 17" 2-Ply, 1/8 Fold)**

Prod No	Description	Application	Color	Pack
DXHS325DN01	Jack-O-Lanterns	Dinner Napkin	Orange, Green, Yellow, Black	100 ea
DXHS341DN01	Autumn Leaves	Dinner Napkin	Orange, Green, Cranberry, Gold	100 ea
DXHR601DN01	Stars & Stripes	Dinner Napkin	Red, Blue	1,000 ea
DXH5455DN01	Poinsettia Blossom	Dinner Napkin	Gold, Black, Red, Green	1,000 ea
DXHS456DN01	Silver & Gold	Dinner Napkin	Blue, Green, Silver, Gold	100 ea
DXHS470DN01	Confetti & Streamers	Dinner Napkin	Silver, Gold, Black	100 ea
DXHS002DN01	Valentine's Day	Dinner Napkin	Red, Pink, Gold	100 ea
DXHS052DN01	St. Patrick's Day	Dinner Napkin	Green	100 ea
DXHS104DN01	Easter Basket	Dinner Napkin	Multi-color	100 ea
DXHS201DN01	Father's Day Ties	Dinner Napkin	Multi-color	100 ea
DXHS701DN01	Celebration	Dinner Napkin	Red, Blue, Yellow, Green	100 ea
DXHS182DN01	Mother's Day Petals	Dinner Napkin	Multi-color	100 ea



CUTLERY CADDIES & PAPER NAPKINS

An Innovative Utensil Presentation.

The Cutlery Caddy is a **unique printed sleeve** pre-loaded with a facial quality tissue napkin that holds utensils for a clean, sanitary presentation with an upscale look. Use the caddy on the traytop for meal delivery as well as for tabletop use in doctors' dining facilities, cafeteria kiosks, long-term care facilities and catering functions.

- **Cuts labor costs for wrapping utensils**
- Increases trayline efficiency
- Can be used with stainless or plastic utensils
- Room to insert meal kits or condiments
- Eliminates loss of utensils and condiments during transport
- **Photo quality custom print available**

Cutlery Caddies & Napkin Sleeves

Cutlery Caddy with Flap Closure

The Cutlery Caddy with Flap comes preloaded with a white, 2-ply trimline napkin. The flap closure completely covers your utensils to provide the most secure fit for transportation. Available in our new Enjoy, Bon Appetit and Filigree designs. Photo quality customization available.

Cutlery Caddy without Flap Closure

Available in regular, large and extra large sizes, the basic Cutlery Caddy with no flap still comes pre-loaded with a white, 2-ply napkin on the regular size and a white airlaid napkin on the large and extra large sizes. Available in our new Enjoy design. Photo quality customization available.

Cutlery Napkin Sleeve

Created for upscale room-service solutions, the innovation napkin sleeve creates a caddy for your cutlery using an airlaid, heavy weight napkin with a decorative band. Available in our new Enjoy design. Photo quality customization available.



Cutlery Caddy Menu

Our latest innovation, the Cutlery Caddy Menu combines ultimate convenience, hygiene and a unique cutlery presentation with extensive communication possibilities. Your cutlery and menu can be presented standing up. Cutlery Caddy Menus are printed with your custom design on the outside and your menu offering on the inside.

Custom Printing

All Cutlery Caddy sizes are customizable at no extra charge. Please allow an 8–10 week lead time once order is placed and artwork is approved.

Dinner Napkins

Dinex facial quality napkins **add a special touch** to your dining service.

Dinex decorator 2-ply dinner napkins are a full 15" x 17" with 1/8 fold and coin edge embossed. They feature superior **"wet strength."**

Information on custom napkins can be found on page 71.

DX6243202836





Pocketfold Napkins

Keep your serving utensils clean and organized with facial quality, 2-ply dinner napkins featuring the unique "pocketfold" from Dinex. Available in Sage, White, or Filigree. Additional colors available as run to order.



Cutlery Caddies

Prod No	Description	Size	Napkin	Pack
Flap Closure				
DXCTCAD1003	Cutlery Caddy with Flap, Black Enjoy	9.25" x 2.75", with Flap	16" x 16", 2-Ply White	600 ea
DXCTCAD1041	Cutlery Caddy With Flap, Natural Wood Enjoy	9.25" x 2.75", with Flap	16" x 16", 2-Ply White	600 ea
DXCTCAD35000	Cutlery Caddy with Flap, Filigree Bon Appetit	9.25" x 2.75", with Flap	16" x 16", 2-Ply White	600 ea
DXCTCAD80003	Cutlery Caddy with Flap, Black Bon Appetit	9.25" x 2.75", with Flap	16" x 16", 2-Ply White	600 ea
DXCTCAD80061	Cutlery Caddy with Flap, Burgundy Bon Appetit	9.25" x 2.75", with Flap	16" x 16", 2-Ply White	600 ea
Full customization available on 24 case orders				
Without Flap Closure				
DXCTCADS1003	Cutlery Caddy, Black Enjoy	7.75" x 3.25", No Flap	13" x 13", 2-Ply White	520 ea
DXCTCADS1041	Cutlery Caddy, Natural Wood Enjoy	7.75" x 3.25", No Flap	13" x 13", 2-Ply White	520 ea
DXCTCADL1003	Cutlery Caddy Large, Black Enjoy	9.25" x 3.25", No Flap	16" x 13", Airlaid White	325 ea
DXCTCADL1041	Cutlery Caddy Large, Natural Wood Enjoy	9.25" x 3.25", No Flap	16" x 13", Airlaid White	325 ea
Custom Only	Cutlery Caddy Extra Large, No Flap	9.25" x 4.50", No Flap	16" x 13", Airlaid White	400 ea
Full customization available on: 24 case size regular orders, 39 case size large orders and 25 case size extra-large orders				
Napkin Sleeve Caddy				
DXCTCADNS1003	Napkin Sleeve, Black Enjoy	16" x 16"	16" x 16", Airlaid White	300 ea
DXCTCADNS1041	Napkin Sleeve, Natural Wood Enjoy	16" x 16"	16" x 16", Airlaid White	300 ea
Full customization of napkin band and additional napkin colors available on 40 case orders.				
Menu Caddy				
Custom Only	Cutlery Caddy Menu	7.75" x 3.25", No Flap	13" x 13", 2-Ply White	400 ea
Full customization of cutlery menu available on 30 case orders				

NAPKIN SIZE: DINNER (15" x 17" 2-Ply, 1/8 Fold)

Prod No	Description	Application	Color	Pack
Pattern Dinner Napkins				
DX6243202836	Freesia Recycled	Dinner Napkin	Cranberry, Mid Blue, Green	1,000 ea

NAPKIN SIZE: POCKETFOLD (17" x 17" 2-Ply, 1/12 Fold)

Prod No	Description	Application	Color	Pack
DX63501113	Filigree, Recycled	Pocketfold Napkin	Black, Gold	1,200 ea
DX6999PF0184	Solid Color	Pocketfold Napkin	Sage	1,200 ea
DX6999PF0202	Solid Color, Recycled	Pocketfold Napkin	White	1,200 ea



MENU FORMS

The perfect way to complete your traytop presentation. Colorful, graphically coordinated menu forms – printed on bright white 24 lb. stock paper – complement the full range of Dinex Traycovers, Napkins, Trayware and Cutlery Caddies. Perforated between each panel for easy folding and separation, Dinex stock menu shells come ready to imprint with your daily menu selections. With interior panels printed in seven industry-standard dietary colors, each panel displays daily breakfast, lunch and dinner selections. The paper and ink specifications are compatible with copiers and laser printers. Menu shells are shrink wrapped in packages of 500 for easy handling.

Information on custom menus can be found on page 71.

- A. Jane's Bouquet
- B. Garden Trellis
- C. Filigree
- D. Iris Garden



PATIENT MENU FORMS (8-1/2" x 14") 3-Panel Perforated (2,000 ea/Pack)

Description	Blank	Breakfast, Lunch & Dinner Headings						
	(No Headings)	Blue	Green	Yellow	Orange	Pink	Gray	Cranberry
Garden Trellis	DX6SM016000	—	—	—	—	—	—	—
Jane's Bouquet	DX6SM055000	DX6SM055300	DX6SM055354	DX6SM055109	—	DX6SM055190	—	—
Iris Garden	DX6SM081000	DX6SM081300	DX6SM081354	DX6SM081109	DX6SM0811585	DX6SM081190	—	DX6SM081222
Filigree	—	DX6SM351300	DX6SM351354	DX6SM351109	—	DX6SM351190	DX6SM351427	—

Tray Tickets

Complete your meal selection system with Dinex Tray Tickets. All are available in standard configurations for laser printers and copiers. Specialty sizes are also available from Dinex.

Information on custom tray tickets can be found on page 71.

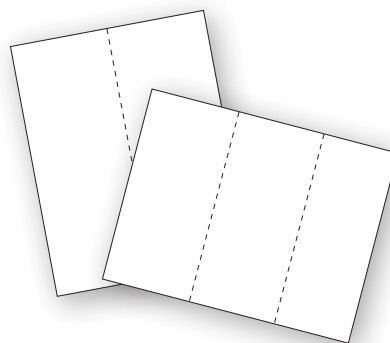

TRAY TICKET FORMS (Unprinted Both Sides)

Prod No	Description	Color	Pack
DX6SM0010000	Blank Laser-Compatible Sheets: 8-1/2" x 14" two 8-1/2" perf (3 panel)	Blank	2,000 ea
DX6ST0010000	Blank Laser-Compatible Sheets: 8-1/2" x 11" one 11" perf (2 panel)	Blank	2,000 ea
DX6ST0040000	Blank Laser-Compatible Sheets: 8-1/2" x 11" two 8-1/2" perf (3 panel)	Blank	2,000 ea

CUSTOM PAPER PRODUCTS



Custom Traycover Designs

Let Dinex design a special traytop, customized exclusively for your facility. Dinex custom printed traycovers feature the same high quality paper and graphics, and are available in most standard or specialty tray configurations. Call your Dinex representative for assistance in designing a custom traycover, napkin and/or menu shell exclusively for your facility.

Special pricing and minimum order quantities may apply to custom designs. Six week lead time needed for production. Contact your Dinex representative for additional information.



Custom Napkin & Cutlery Caddy Designs

Complement the look of your custom traycover with a customized napkin. Dinex facial quality napkins lets you coordinate a colorful and attractive traytop display for every setting. Dinex 2-ply dinner napkins are a full 15" x 17" with 1/8 fold and coin edge embossed. Contact your Dinex sales representative for more information on customizing your presentation.

Custom Menus and Tray Tickets

Whether you want to save time and simplify meal planning, match your unique decor or simply look your best, Dinex will custom print your organization's name and message on our stock menu shell designs, or produce a complete custom-designed menu or tray ticket exclusively for you.





CARLISLE
MANUFACTURING

DINEX CARLISLE

DINEX

SMART
INNOVATIVE
EFFICIENT
**INDUCTION
HEATING
SYSTEMS**

Only Dinox induction systems offer the latest in innovative, high-speed induction technology for today's dynamic foodservice demands and allow faster tray assembly, efficient roomservice operation and premium food quality.





INDUCTION BASE HEATING SYSTEMS

Hospitals with **more than 250 beds**, facilities with longer meal delivery time or having **challenges with their food temperatures** need DuraTherm, the most innovative induction heating system on the market. **DuraTherm offers between 75 and 90 minutes holding time without compromising food quality to increase patient satisfaction scores.**

Combine these products with your induction system.



Colossus Plate Heaters
page 128



DineXpress Steamtables
pages 102-104



Drying Racks
page 136



Mobile Stainless Steel Table
page 78

DuraTherm™ Induction Charger



Check our DineX app for the complete hot holding solutions.

Smart: Microprocessor reads bases and monitors charging cycles to give the correct amount of heat and allow consistent temperature every time

Efficient: Charge up to 4 bases per minute or 240 bases per hour on 208V 3-Phase

User-Friendly: Clear LCD display shows charging status of bases

NSF & ETL Listed

Versatile: DuraTherm charges DX1411 bases in 15 seconds offering a holding time between 75 and 90 minutes and DX8210 bases (Smart•Therm II) in 10 seconds for a holding time of up to 45 to 60 minutes

Compact: Most compact charger on the market; it can be placed anywhere along the room service line to create a lean environment and improve the efficiency of any operation

Peace-of-Mind: Two-year limited warranty; extended warranty available for purchase



Hotter Bases



Premium Quality

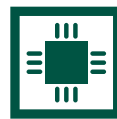

Microchipped



Compact



Lightweight

DuraTherm™ Induction Bases



Not All Plates are Created Equal

Using DineX plates is the best solution to offer premium food quality at the optimal temperature

Smart: Features a built-in chip that relays information to the charger to get consistent and accurate pinpoint temperature every time; protects the base from over-heating

Preserve Food Quality: At a peak temperature of 240° F, DuraTherm base keeps hot food hot between 75 and 90 minutes without the risk of cooking or drying out the food for premium-quality meals

User Friendly: Bases are cool to the touch for safety and are the lightest on the market for ease of use

Durable: Bases feature a watertight construction; bases cannot be stacked due to higher peak temperatures and cannot be used in a Microwave

Efficient: Contains internal phase changing material that requires lower energy input to hold temperatures longer

Peace-of-Mind: 2 year warranty; NSF Listed

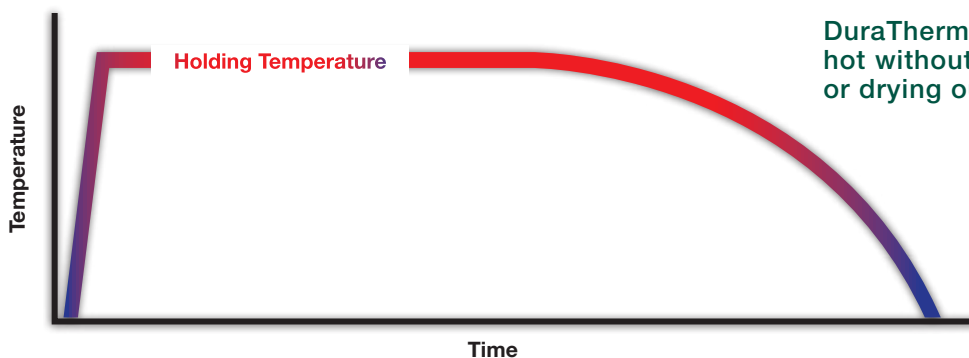

Prod No	Description	Electrical	L x D x H	Pack
DuraTherm Induction Chargers				
DX2011208 Δ	DuraTherm Induction Charger	208v 3-Phase 20 Amps	15.26" x 18.3" x 7" / 38.8 x 46.5 x 17.8 cm	1 ea
Prod No	Description	Color	Pack	
Induction Bases				
DX1411 Δ	Base for DuraTherm Induction Chargers	03, 31, 44, 50, 61, 84	12 ea	

Color	Count
Onyx(03)	Latté(31)
Graphite(44)	Midnight Blue(50)
Cranberry(61)	Sage(84)

DineX by CFS Brands NSF Listed products are designated with a Δ and may be prefixed with an N



INDUCTION BASE HEATING SYSTEMS

Today's demanding foodservice traylines and room service operations need **Smart•Therm II**. This induction system features a **unique boosting mode** and offers a **holding time of 45 to 60 minutes**.



Smart•Therm II® Induction Charger



Smart: Microprocessor reads bases and monitors charging cycles to allow re-heating to the proper pinpoint temperature

Efficient: Charge up to 205 bases per hour with Smart•Therm II 240v and 102 bases per hour with Smart•Therm II 120v for 45 to 60 minutes holding time; the charger senses base automatically and gives the correct amount of heat to allow consistent temperature every time

User Friendly: Clear LCD display shows charging status of bases

Flexible: Single unit works on all 208v, 220v and 240v systems

- Automatic shut-off feature prohibits overheating
- Space efficient countertop design
- Easy-to-clean composite top surface
- Uses the interactive DX8210 Series base from Dinex
- Cycle time ranges from 16 to 19 seconds depending on voltage supply
- NSF & ETL Listed
- 2-year limited warranty—extended warranty available for purchase

Smart•Therm II® Induction Bases

Smart: The built-in microchip relays information to the charger to heat and re-boost (Smart•Therm II only) and protects the base from over-heating

Durable: One-piece molded base is watertight and has a 2-year limited warranty

User Friendly: Bases are cool to the touch for user safety, stackable for operational efficiency and are the lightest on the market

Efficient: Contains internal phase changing material that requires lower energy input to hold temperatures longer



Prod No	Description	Electrical	L x D x H	Pack
Smart•Therm II Induction Chargers				
DX811220 Δ	Induction Charger	208v, 220v & 240v, 1-Phase	15.26" x 18.3" x 7" / 38.8 x 46.5 x 17.8 cm	1 ea
DX1011120RS Δ	Room Service Induction Charger	120v, 1-Phase	15.26" x 18.3" x 7" / 38.8 x 46.5 x 17.8 cm	1 ea
Prod No	Description	Color	Pack	
Induction Bases				
DX8210 Δ	Base for Smart•Therm II Induction Chargers	03, 31, 44, 50, 61, 84	12 ea	

Dinex by CFS Brands NSF Listed products are designated with a Δ and may be prefixed with an N

Smart•Therm II® vs DuraTherm™



Features

Smart•Therm II

DuraTherm

For Whom

Hospitals with less than 250 beds or long-term care facilities with less than 100 beds

Hospitals with more than 250 beds having long meal delivery times & challenges with their food temperatures

Hold Times

Holding Time Between 45 to 60 minutes with a hot plate

Between 75 and 90 minutes with a hot plate

Heating Phase changing technology absorbs, stores and releases heat

Phase changing technology absorbs, stores and releases heat

Culinary Zero risk of cooking or drying food

Zero risk of cooking or drying food

Performance

Charging Time 16-19 seconds at 208v 1-Phase
35 seconds at 120V 1-Phase

15 seconds

Power Requirements 208v – 240v Single Phase

208v 3-Phase

Boost Capability YES

NO

Smart Technology Embedded microchip

Embedded microchip

Base Surface Temperature Up to 205°F

240°F Minimum

Durability

Base Construction Completely sealed, watertight, one-piece design with zero exposed electrical components

Completely sealed, watertight with zero exposed electrical components

Charger Automatic shut-off feature

Automatic shut-off feature

Ergonomics & Flexibility

Charger Dimensions & Weight 15.26" × 18.30" × 7.01" / 24 lbs

15.26" × 18.30" × 7.01" / 26 lbs

Weight of Base 1.42 lbs

1.65 lbs

Safety Cool to the touch

Cool to the touch

User Interface LCD display to track charging process

LCD display to track charging progress

Ease of Base Placement Base placement from any direction

Base placement from any direction

Customer Support

Warranty 2-year limited warranty on charger & base

2-year limited warranty on charger & base

Extended Warranty YES

YES

Hotline 24/7 Hotline

24/7 Hotline

Exchange Program YES

YES

Overnight Shipping for Replacement* YES

YES

Works With

Induction Base DX821 series

DX1411 and DX821 series

Plug

Induction Base NEMA L6-20

NEMA L15-20P

*Orders need to be received before 2 pm CST



CHARGING STATIONS

Induction Charger Table

- Compact 30" x 24" size stainless table conveniently holds Smart•Therm II or DuraTherm induction base heating systems
- Second storage shelf below holds extra bases or other serving accessories
- Available as stationary table or with locking caster

Shown with Smart•Therm II and DX821 Induction Bases



DXICTABLEM



Product Specifications Can Be Customized

Shown with DuraTherm Charger



DXIQTEC

Induction Charger Cabinet/Stand

- Compact 22" x 20" size stainless table conveniently holds Smart•Therm II or DuraTherm induction base heating systems
- Locking cabinet below holds extra bases or other serving accessories
- Locking casters offer easy portability



Product Specifications Can Be Customized

Prod No	Description	L x D x H	Pack
Induction Charger Tables			
DXICTABLE	Table for Induction Charger (Stationary with Leveling Feet)	30" x 24" x 30.12" / 76.2 x 61 x 76.5 cm	1 ea
DXICTABLEM	Table for Induction Charger (Mobile with Locking Casters)	30" x 24" x 30.12" / 76.2 x 61 x 76.5 cm	1 ea
Induction Charger Cabinet/Stand			
DXIQTEC	Cabinet/Stand (Enclosed with Locking Door)	21.75" x 20.5" x 26" / 55.2 x 52.1 x 66 cm	1 ea

Starter/Checker station for Room Service POD Systems

Only Dinex brings you this solution to save space and increase productivity.

- 30" x 24" footprint is ideal for room service pod systems
- Constructed of durable stainless steel
- **Adjustable shelving** with 4 different heights
- Comes with 6 plastic bins for organizing utensils and condiments
- Also works great as a checker station for those little items often missed, keeps your trayline moving
- Available with or without casters
- NSF Listed



DXICATABLEMSS
Shown with Smart•Therm II, Induction Bases,
DXTMP30-240 Plastic Bin &
DXTMP30-176 Plastic Bin Divider



DXICATABLESS



Product Specifications
Can Be Customized



4 height adjustments to customize for your needs

Prod No	Description	L x D x H	Pack
Adjustable Mini Starter/Checker Stations			
DXICATABLESS Δ	Mini Starter/Checker Station (Stationary with Leveling Feet)	30" x 24" x 60.75" / 76.20 x 60.96 x 154.31 cm	1 ea
DXICATABLEMSS Δ	Mini Starter/Checker Station (Mobile with Locking Casters)	30" x 24" x 60.75" / 76.20 x 60.96 x 154.31 cm	1 ea
Accessories			
DXTMP30-176	Plastic Bin Divider	—	1 ea
DXTMP30-240	Plastic Bin	—	1 ea

Dinex by CFS Brands NSF Listed products are designated with a Δ and may be prefixed with an N



DINEX

QUALITY
SOLUTIONS
INNOVATIVE
FUNCTIONAL
**SERVING
SYSTEMS**

*Proper serving temperatures. Great food quality.
State-of-the-art technology. User friendly
equipment. Only Dinx serving systems deliver all
of these in quality meal solutions to patients and
residents in acute and long term care settings.*



HOT & COLD MEAL SERVICE

Offer **active hot and cold food holding on trays** anywhere in your facility with Dinex new Meals On Command II.

Meals On Command II

Optimize Time Management

Save time and labor by running your tray assembly in advance and maintain hot and cold temperatures.

- **Hot and Cold Temperature Control**

Active hot and cold holding on a 120V 20 amp outlet when the cart is powered

- **Hotel Style**

Dishware flexibility: No need of specific wax base, induction base, insulated ware or other cold container to bring the patients' experience to the next level

- **Ideal for meal delivery in acute and long term care**

Some of the key applications could be oncology, pediatrics, maternity, units with patient requiring assistance with feeding, Emergency room requiring extended temperature holding or when nursing staff is in charge of delivering trays



Meals on Command II Key Features

- Active hot and cold temperature holding
- Convection heat on hot side & forced air on cold side
- 20 tray capacity cart
- 120V 1 phase 20 amp
- LCD display with hot and cold temperature information
- 4 insulated doors with colored handles
- 6 casters, 4 swivel, 2 fixed, central breaking system
- 2 vertical door handles with finger shaped design
- Full Perimeter bumper
- Insulated center wall with removable air dams
- Removable tray slides
- Top surface for accessories



Thermal•Aire III & Meals On Command II Patient Trays
page 46



Use our specialty cart for soiled tray pick-up.

Specialty Cart
page 150



Prod No	Description	L x D x H	Pack
Meals On Command II - Hot/Cold Delivery Carts - 120v, 15.4A (requires 20A service with a 5-20P plug)			
DXMOCII20	Hot/Cold Tray Delivery System (Holds 20 Divided Trays)	44.6" x 30.5" x 56.6" / 113.5 x 77.5 x 141.3 cm	1 ea
Meals On Command II Tray Retrieval Cart			
DXMOC20RCDX1387 ▲	Tray Retrieval Cart (20 Trays, 2 Per Slide)	26.5" x 31" x 47.63" / 67.3 x 78.7 x 121 cm	1 ea

Dinex by CFS Brands NSF Listed products are designated with a ▲ and may be prefixed with an N

BOOST

HOT & COLD TEMPERATURES

Solve your hot and cold temperature problems once and for all.



DXTAIII47920204

Thermal•Aire III™ System for Boosting

- **Thermal•Aire III boosts hot food temperatures to at or above HACCP guidelines while decreasing cold food/beverage temperatures simultaneously**
- Gain complete **confidence** in a system that delivers hot food at 165°F or above and cold food as low as 33°F in a conventional hot trayline application
- **Excellent option for facilities having challenges with food temperatures or satellite feeding**
- **Eliminates the need for a satellite kitchen to deliver food off-site**
- The “repetition” mode allows each cart to instantly begin a boosting cycle without touching any buttons for multiple docking sequences per allotted time interval
- **In a typical operation one docking station will boost three carts per meal period, making it very cost effective**
- See page 90 for more information

All upgrades must be ordered at the same time as the product.

Prod No	Description	L x D x H	Capacity	Pack
Thermal•Aire III Junior Carts				
DXTAIII4792020	20 Tray Capacity Junior TAIll Cart	36.2" x 31.3" x 52"	20 Tray	1 ea
DXTAIII4792024	24 Tray Capacity Junior TAIll Cart	36.2" x 31.3" x 52"	24 Tray	1 ea
Thermal•Aire III Junior Docking Stations				
DXTAIII4782002	Junior TAIll Docking Station, Air-Cooled Compressor	37.4" x 22.8" x 68.7"	—	1 ea
Thermal•Aire III Senior Carts				
DXTAIII4792026	26 Tray Capacity Senior TAIll Cart	36.2" x 31.3" x 61.2"	26 Tray	1 ea
DXTAIII4792030	30 Tray Capacity Senior TAIll Cart	36.2" x 31.3" x 61.2"	30 Tray	1 ea
Thermal•Aire III Senior Docking Stations				
DXTAIII4782003	Senior TAIll Docking Station, Air-Cooled Compressor	37.4" x 22.8" x 78"	—	1 ea

MEALTIMEEXPRESS™

Only Dinox provides the most versatility to **create great dining experiences** for residents in a group setting. Plate and serve **tasty meals** in front of residents to increase **appetite appeal** and avoid that institutional tray experience.



Customers who purchase MTX also purchase TQ Supreme Carts for in-room tray delivery. See page 142 for additional details.

- Versatile bulk service unit to help **maintain HACCP hot and cold temperatures**
- 2 models are available—one with one hot and one cold compartment and one with two hot compartments
- Serves up to **40 meals** depending on portion size and meal variety
- Serves up to 100 meals with the hot/hot version coupled with an air curtain refrigerator for the cold food items (see page 122 for available air curtain models)
- Can be plugged in anywhere with a standard **120V 20 Amp plug**

Stainless steel panels come standard. A variety of optional laminate panels are available. Please visit Wilsonart®* at www.wilsonart.com to make your selection.

Use **Cateraide IT** (page 185) to safely transport food pans from your kitchen to serving areas in satellite applications.



Watch our Video on the MealtimExpress Cart at www.carlislefsp.com/videos



Product Specifications Can Be Customized



Shown with optional tray slide, drop down end shelf and laminate panels

- **Convection heat ensures even temperatures** throughout compartment
- Ergonomic design and large heated top surface allows for easy plate assembly
- Four, 6-inch caster configuration, (4) swivels located at corners, allow zero turning radius
- Sliding internal cassettes suitable for simple placement on transfer dolly (optional), easily accessible interior service components, smooth covered food cavities to provide easy cleaning
- Full perimeter bumpers and push handle included



High Heat Food Pans
page 200



Low Temp Food Pans
page 198



Stainless Steel Food Pans
page 201

MealtimExpress Transfer Dolly

- Prepare bulk foods in a remote location and transfer to MealtimExpress
- The dolly features a simple release mechanism to transfer loaded cassettes into the cart bays
- An insulated, vinyl cart cover available (optional)

* Wilsonart is a registered trademark. Dinox is not associated in any way with Wilsonart.

From cafeteria to concessions, MealtimEXpress is the **creative solution** for satellite foodservice.

- Perfect choice for any satellite or remote feeding in healthcare or hospitality
- Use for meal service in acute care facilities such as doctors' dining lounges, cafeterias or as a portable kiosk
- Ideal for satellite application in schools, sporting venues, convention centers
- Our customization program allows you to broadcast your personalized message
- Easily accessible interior service components and smooth covered food cavities provide easy cleaning



Dinnerware
page 162



Measure Misers
page 192

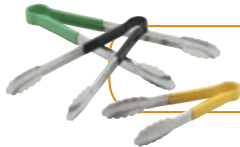

Tongs
page 193

Build your serving station and delight your guests with a premium service at the right food temperature

Shown:
MealtimEXpress Hot/Hot (DXMTXHH) • Plate Heater (DXIDPH2E0912)
Cateraite IT (IT40003) • Air Curtain (DXIRAC15EF)



All upgrades must be ordered at the same time as the product.



Prod No	Description	L X D X H	Amps	Pack
MealtimEXpress Units - 120 Volts - (8 Full Size or 16 Half Size Pans Per Compartment)				
DXMTXHR	One Hot Compartment & One Refrigerated Compartment	52.35" x 54.52" x 28 69" / 132.97 x 138.48 x 72.87 cm	15.5	1 ea
DXMTXHH	Two Hot Compartments	52.35" x 54.52" x 28 69" / 132.97 x 138.48 x 72.87 cm	19	1 ea
MealtimEXpress Transfer Dolly				
DXMTXTD	Standard Transfer Dolly	33.80" x 96.52" x 64/52" / 85.85 x 96.52 x 64.52 cm	—	1 ea
MealtimEXpress Unit & Support Cart Options				
DXMTXFLP	Laminate Panels (Select Pattern/Color at www.wilsonart.com)	—	—	1 ea
DXMTXTS	3 Bar Fold Down Tray Slide	—	—	1 ea
DXMTXDDES	Drop Down End Shelf	—	—	1 ea
DXMTX8C	Additional Cassettes - 8 shelves (for extra quantities)	—	—	1 ea
DXMTXTDVC33U ♦	Vinyl Cover for Transfer Dolly	—	—	1 ea
DXMTX7C	Additional Cassette - 7 shelves (for extra quantities)	—	—	1 ea
DXDOUT	Duplex Outlet for Support Cart	—	20	1 ea

* Wilsonart is a registered trademark. DineX is not associated in any way with Wilsonart.

♦ California Residents: Di(2-ethylhexyl)phthalate (DEHP) WARNING: See appendix B on page 281



SUPPORT CART

- An **efficient system** for serving and transporting supplies
- Reduces work and **creates a complete meal experience**
- Premium quality stainless steel with rugged casters and push handle
- Generous work top for trays, serving pitchers, etc.
- The Support Cart features on-board electrical connection, drop-shelf, convenient bins and shelving for supplies

Stainless steel panels come standard. A variety of optional laminate panels are available. Please visit Wilsonart® at www.wilsonart.com to make your selection.



Product Specifications
Can Be Customized



MOBILE HEATED CABINET

For 18" x 26" Trays & 12" x 20" Pans

- Perfect for maintaining **consistent temperatures**
- Features a **high-performance blower** with a 1,600 watt heating element to assure even distribution of heated air throughout the cabinet
- Stainless steel construction with heavy-duty push-handles and fiberglass insulation
- Units are available with a maximum capacity of 12 pans or 24 trays for 10 slide cabinet; or 16 pans or 32 trays for 12 slide cabinet
- NSF Listed



All upgrades
must be ordered
at the same time
as the product.



Prod No	Description	L x D x H	Amps	Pack
---------	-------------	-----------	------	------

Support Cart

DXMTXSCN1	Support Cart	52.35" x 37.81" x 29.19" / 132.97 x 138.48 x 72.87 cm	—	1 ea
-----------	--------------	---	---	------

MealtimeXpress Unit & Support Cart Options

DXMTXFLP	Laminate Panels (Select Pattern/Color at www.wilsonart.com)	—	—	1 ea
DXMTXTS	3 Bar Fold Down Tray Slide	—	—	1 ea
DXMTXDDES	Drop Down End Shelf	—	—	1 ea
DXMTX8C	Additional Cassettes - 8 shelves (for extra quantities)	—	—	1 ea
DXMTXTDVC33U ♦	Vinyl Cover for Transfer Dolly	—	—	1 ea
DXMTX7C	Additional Cassette - 7 shelves (for extra quantities)	—	—	1 ea
DXDOUT	Duplex Outlet for Support Cart	—	20	1 ea

Heated Cabinets - 120 Volts, 1650 Watts

DXHC20 Δ	Heated Cabinet (10 Slides - 12 Pans or 24 Trays)	30.63" x 36" x 58" / 77.8 x 91.4 x 147.3 cm	13.7	1 ea
DXHC24 Δ	Heated Cabinet (12 Slides - 16 Pans or 32 Trays)	30.63" x 36" x 71" / 77.8 x 91.4 x 180.3 cm	13.7	1 ea

Heated Cabinet Options

DXHCHANGLES	Two Stainless Steel Push Handles	—	—	1 ea
DXHCLATCH	Transport Latch, Top Mounted	—	—	1 ea
DXHCMENU	Menu Card Holder	—	—	1 ea
DXHCLIDES	Two Additional Slides	—	—	1 ea

Dinex by CFS Brands NSF Listed products are designated with a Δ and may be prefixed with an N

* Wilsonart is a registered trademark. Dinex is not associated in any way with Wilsonart.

♦ California Residents: Di(2-ethylhexyl)phthalate (DEHP) WARNING: See appendix B on page 281

HYDRATION CART

Dinex offers the most **durable** and **practical** hydration cart in the industry. Provide **hydration and nutrition** to residents and patients throughout the day. A perfect addition for all **long term** and **acute care** facilities, the hydration cart's attractive design encourages impulse fluid consumption.

Stainless steel panels come standard. A variety of optional laminate panels are available. Please visit Wilsonart®* at www.wilsonart.com to make your selection.



- Full stainless steel construction for durability and cleanability
- Large counter top to hold water pitchers, sodas or a beverage service
- Marine edge on top to contain spills
- Standard options are a condiment shelf on top and a push handle on the right side
- Customizable with Wilsonart®* laminates

Watch our Dinex Video on the Hydration Cart at www.carlislefsp.com/videos

 **Product Specifications Can Be Customized**

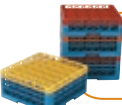
 **OptiClean Washracks**
page 214

 **Coldmaster CoolCheck**
page 209

 **Trays & Traytop**
page 26

 **Cascata Carafes**
page 168

 **TrimLine Single Base**
page 132
(FoodService Catalog)



Cart includes four standard Adjustable Roller Shelves



Available with optional Cup Dispensers, Doors and Drawers

Prod No	Description	L x D x H	Pack
Hydration Cart			
DXHYDCT	Hydration Cart	53.75" x 27.19" x 64.92"	1 ea
Options			
DXHYDLD	Drawer Assembly	24" x 8" x 24"	1 ea
DXHYDCP	Cup Dispenser Assembly	24" x 8" x 30"	1 ea
DXHYDES	Drop Down End Shelf	28" x 18" x 4"	1 ea
DXHYDRSD	Right Side Door	24" x 24" x 3"	1 ea
DXHYDLSLSD	Left Side Door	24" x 24" x 3"	1 ea
DXHYDSGR	Sliding Glass Racks	26" x 24" x 6"	1 ea
DXHYDFLP	Laminate Panels	48" x 24" x .5"	1 ea
DXHYDFLPD	Laminate Panels for Doors (per Door)	24" x 24" x .5"	1 ea

* Wilsonart is a registered trademark. Dinex is not associated in any way with Wilsonart.



DINEX

ULTIMATE TEMPERATURE SOLUTIONS **RE THERM SYSTEMS**

At Dinex we have state-of-the-art solutions for cook/serve boosting, satellite or cook-chill application. Our systems allow you to assemble food in advance, keep it cold, reheat and maintain both hot and cold food temperatures for extended periods. Save time and labor and optimize food quality with Dinex retherm systems.





THERMAL•AIRE III™

Only Thermal•Aire III gives you **complete confidence** that you can **maintain hot and cold food temperatures** in your boosting, satellite and cook-chill operation so you can serve meals that **deliver patient satisfaction**.

Only Dinex has Thermal•Aire III, the most **advanced meal delivery system** that **assures a premium quality meal** at the correct hot and cold food temperatures. Originally designed for cook-chill systems, cook-serve systems benefit from its boosting capabilities as well. Thermal•Aire III is the **complete solution** and features hotel style serving trays for a less institutional look and stylish high heat wares.

**NEW
PRODUCT**



New 4 Door Thermal•Aire III Cart & Docking Station

Thermal•Aire III Docking Station

- **Innovative** Combines a convection oven for hot food at 165°F (74°C) or above on one side and a ventilated refrigerator for cold food as low as 33°F (0°C) on the other side
- **Flexible** Can be installed in a kitchen, on the patient floor, or in an alternate area
- **Great Food Quality and Variety** Maintains great food quality and allows for a variety of menus, including the capability to bake fresh cookies, biscuits, dinner rolls, cinnamon rolls, and also delivers crispy fried chicken or french fries
- **Ergonomic** Easy cart docking, easy-to-read control panel, casters provide easy installation for relocation, service or floor cleaning
- **HACCP Monitoring in Real Time** The docking station has a built-in ethernet port for real-time monitoring to a PC allowing you to centralize information, program or edit retherm cycles, visualize temperature charts, and print reports

Combine these products with your rethermalization system.

See product chart on page 92



Retrieval Carts
pages 82



Tray Dispensers
pages 133



Dome Storage Rack
pages 136



**NEW
PRODUCT**

Thermal•Aire III™ Cart

- **Flexible** Available in Junior (20 and 24 tray) or Senior (26 and 30 tray) capacities in 2 or 4 door versions
- **Optimum Results** Hot and cold sides with a unique flat tray prevent any heat transfer
- **Durable** No on-board electronics to damage, upper and lower bumpers protect the cart
- **Secure** Secondary door latch is standard on the two-door version for extended transport distances
- **Ergonomic** Top rail and handles set at optimum height
- **Easy to Maneuver** Lightweight cart with optimal handle and rail positioning allow for easy maneuvering; larger diameter front casters decrease rolling friction
- **HACCP Compliant** Easy to clean and sanitize with easy access to all components



Thermal•Aire III Cart New Four-Door Version



Thermal•Aire III Cart



High insulated center wall with automatic Aire-Dams helps maintain separate hot and cold food temperatures



Tray rack, separation grids are all removable without the need for tools to allow easy access for cleaning





THERMAL•AIRE III™

All upgrades must be ordered at the same time as the Thermal•Aire unit.

Prod No	Description	Tray Spacing	L x D x H	Capacity	Pack
Thermal•Aire III Junior Carts - 2 Doors					
DXTAIII4792020	20 Tray Capacity Junior TAIll Cart	3.5" - 9 cm	36.2" x 31.3" x 52"	20 Trays	1 ea
DXTAIII4792024	24 Tray Capacity Junior TAIll Cart	2.9" - 7.4 cm	36.2" x 31.3" x 52"	24 Trays	1 ea
Thermal•Aire III Senior Carts - 2 Doors					
DXTAIII4792026	26 Tray Capacity Senior TAIll Cart	3.5" - 9 cm	36.2" x 31.3" x 61.2"	26 Trays	1 ea
DXTAIII4792030	30 Tray Capacity Senior TAIll Cart	2.9" - 7.4 cm	36.2" x 31.3" x 61.2"	30 Trays	1 ea
Thermal•Aire III Junior Carts - 4 doors					
DXTAIII47920204	20 tray capacity - 4 Doors	3.5" - 9 cm	36.2" x 31.3" x 61.2"	26 Trays	1 ea
DXTAIII47920244	24 tray capacity - 4 Doors	2.9" - 7.4 cm	36.2" x 31.3" x 61.2"	30 Trays	1 ea
Thermal•Aire III Senior Carts - 4 doors					
DXTAIII47920264	26 tray capacity - 4 Doors	3.5" - 9 cm	36.2" x 31.3" x 61.2"	26 Trays	1 ea
DXTAIII47920304	30 tray capacity - 4 Doors	2.9" - 7.4 cm	36.2" x 31.3" x 61.2"	30 Trays	1 ea
Thermal•Aire III Junior Docking Stations					
DXTAIII4782002	Junior TAIll Docking Station, Air-Cooled Compressor	—	37.4" x 22.8" x 68.7"	—	1 ea
DXTAIII4782102	Junior TAIll Docking Station, Remote Compressor	—	37.4" x 22.8" x 68.7"	—	1 ea
DXTAIII4782202	Junior TAIll Docking Station, Water-Cooled Compressor	—	37.4" x 22.8" x 68.7"	—	1 ea
Thermal•Aire III Senior Docking Stations					
DXTAIII4782003	Senior TAIll Docking Station, Air-Cooled Compressor	—	37.4" x 22.8" x 78"	—	1 ea
DXTAIII4782103	Senior TAIll Docking Station, Remote Compressor	—	37.4" x 22.8" x 78"	—	1 ea
DXTAIII4782203	Senior TAIll Docking Station, Water-Cooled Compressor	—	37.4" x 22.8" x 78"	—	1 ea

Prod No Description

Thermal•Aire III Cart Options

DXTAIII4794004	Telescopic Towbar
DXTOWHITCHNR-2	Swivel Tow Bar Device - Non Retractable
DXTAIII4794010	Kit of 4 Stainless Steel Casters
DXTAIII4794015	Kit of 4 Casters with Central Brake, 2 - 6.25" Casters and 2 - 8" Casters
DXTAIII4794012	Kit of 6 Casters, 2 Swivel with Brake
DXTAIII4794013	Kit of 6 Casters, Central Brake
DXTAIII4794014	Kit of 6 Stainless Steel Casters with Central Brake
DXTAIII4794020	Door Latch with Lock for Transportation
DXTAIII4794021	Lockable Door Latch with Triangular key
DXTAIII4794040	Plastic Side Protection for Cart

Prod No Description

HACCP Monitoring Solutions

DXTAIII4940100	i-Serv USB Flash Drive
DXISERVVISION	i-Serv Vision HACCP Software
DXTAIII4935002	i-Serv Pack with software and CPU

For questions, information, or pricing please contact dinexrethermsolutions@carlislefsp.com



THERMAL•AIRE TRAYS

Thermal•Aire & Meals on Command II Trays

- Trays with antimicrobial technology molded into the tray are designed to help prevent the growth of stain and odor-causing bacteria keeping the tray cleaner between washings
- Antimicrobial protection works continuously for 24/7 protection, keeping the food trays cleaner for longer and won't wash off or wear away, even when scraped
- Ergonomic design with a patient-pleasing look
- Please note antimicrobial protection does not protect users from foodborne illness and is not a substitute for normal cleaning practices



High Heat Disposable Dishware coordinates with Tropez high-heat dome covers, mugs, bowls and disposables (shown on pg 34).



Thermal•Aire Patient Trays

- Retherm trays combine with Tropez high-heat dome covers, mugs, and bowls (shown on pg 30)
- Coordinates with Dinex China, high heat plastic, disposables and a variety of contemporary traycovers (starting on page 58)



Prod No	Description	Color	L x W x H	Pack
Thermal•Aire & Meals on Command II Patient Tray				
DXSC1531002	13" x 21" Individual Meal Tray	03, 23*	13" x 21" / 15.3 x 33 cm	24 ea

*Only Gray(23) is offered with antimicrobial protection



PERFECT•SERV® ULTRA

Perfect•Serv® Ultra Bulk Food Retherm System

Serve tasty, nourishing meals that are at the proper temperature with Perfect•Serv® Ultra. Perfect•Serv® Ultra is a stylish and **efficient rethermalization oven and refrigerator** that allows cold storage and bulk rethermalization in one compact easy-to-use cart. **It's the ideal solution for resident dining rooms and satellite dining.** Perfect•Serve Ultra is your kitchen on wheels! The Perfect•Serv Ultra cart will hold chilled food at 35°F (2°C) and then rethermalize it with the push of a button, or pre-scheduled on a 7 day timer.

Perfect•Serv Ultra carts provide faster rethermalization, are more ergonomically safe and produce the best quality rethermalization results in its class.

- **Innovative** Touch screen control panel for easy programming
- **Convenient** Large work area with 2 programmable top heat zones, automatic cycle start, easy loading of food
- **Customizable** Optional folding tray shelf and end shelf, laminate panels in a variety of colors to fit your dining decor
- **Technology** Convection rethermalization results in improved food quality, menu variety, and flexibility; no pre-heat required
- **HACCP Compliant** Temperature logs and historical data can be downloaded on a computer with a USB flash drive; cart is easy to clean and sanitize
- Conforms to HACCP food safety regulations and recommendations



High Heat Food Pans
page 200



Stainless Steel Food Pans
page 201



Dinnerware
page 162

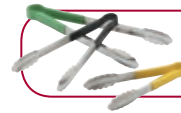

Tongs
page 193



Measure Misers
page 192



User friendly touch screen
Food probe on both sides



7 or 8 shelf sliding cassette for
full, half or third size pans



Fold down slide tray and end
shelf are available as an option

All upgrades must be ordered at the same time as the Perfect•Serv unit.



Cateraide IT
pages 184



Perfect•Serv® Ultra Transfer Dolly

- 7 or 8 shelf sliding cassette for full, half or third pans
- Easi-Roll™ cassettes allow chilled bulk food pans to be prepared in any remote assembly application and transferred to the Perfect•Serv Ultra cart
- Features a simple release mechanism to transfer loaded cassettes into the cart bays
- Optional insulated vinyl cart cover is available
- Can also use Carlisle Cateraide IT insulated transport line to safely transport food pans from your kitchen to your serving area in satellite applications

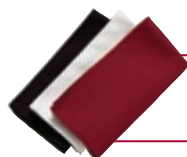

Marko Napkins
page 177

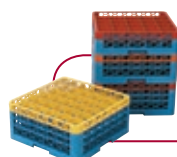

OptiClean Washracks
page 214



Marko Embrace
page 176



Cascata Carafe
page 168

Perfect•Serv® Ultra Support Cart

- Provides all the necessary utilities for serving, and an organized system for transporting supplies
- Constructed of premium quality, food service grade stainless steel with rugged casters and push handle
- Features on-board electrical connection, drop-shelf and convenient bins and shelving for supplies
- Generous amount of “working space” on top for trays and urns, etc



The support cart holds trays, china, napkins, utensils and beverage dispensers along with all necessary serving supplies.

Stainless steel panels come standard. A variety of optional laminate panels are available. Please visit Wilsonart®* at www.wilsonart.com to make your selection.

Prod No	Description	L x W x H	Pack
Perfect•Serv Ultra Retherm System - 208/220-240V - 60HZ			
DXPSUCR	Perfect•Serv Ultra, includes 1 Chillotherm (hot/cold) compartment and 1 Refrigerator (cold) compartment, 8 Shelves each	60.19" x 28.74" x 54.58"	1 ea
DXPSUCC	Perfect•Serv Ultra, includes 2 Chillotherm (hot/cold) compartments, 8 Shelves each	60.20" x 28.75" x 54.59"	1 ea
Perfect•Serv Ultra Support Cart			
DXMTXSCN1	Support Cart	52.35" x 37.81" x 29.19"	1 ea
Perfect•Serv Ultra Transfer Dolly			
DXMTXTD	Standard Transfer Dolly	33.80" x 96.52" x 64/52"	1 ea

Options & Accessories For Above Perfect•Serv Units

Prod No	Description
Perfect•Serv Ultra Options	
DX10454	Adaptator Cord for DXPSUCR
DX10455	Adaptator Cord for DXPSUCC
DXMTX7C	7 level cassette (for extra quantities)
DXMTX8C	8 Level Cassette (for extra quantities)
DXMTXTDVC33U ♦	Vinyl cover for transfer dolly cart (covers 2 cassettes)
DXPSUES	Drop Down end shelf
DXPSUTB	Towing Bar
DXSUTP	Integral Food Temp Probe With Holster - Detachable (for extra quantity - one is provided in standard)
DXPSUFTS	Folding Tray Shelf (Front)
DXPSUFLP	Laminate panel for Perfect•Serve Ultra

* Wilsonart is a registered trademark. Dinex is not associated in any way with Wilsonart.

♦ California Residents: Di(2-ethylhexyl)phthalate (DEHP) **WARNING:** See appendix B on page 281



DineXpress
PERFORMANCE

DINEX

FRONT & BACK OF HOUSE MODULAR SERVING COUNTERS

Dinex modular counters offer unlimited configurations and customization options. While Dinex counters are available for the conventional back-of-house trayline or POD systems, they can also be completely upgraded for your front-of-house serving systems.



WHY DINEXPRESS MODULAR SERVING COUNTERS?

DineXpress is a customizable and modular serving system that will boost your retail sales. Not only does it create an enhanced dining experience for front-of-house, it also increases efficiency and productivity in back-of-house. Key applications are but not limited to:

- **Healthcare Cafeteria and All Day Dining**
- **Education K-12 and University**
- **Hospitality, Employee Break-Room**



Our Dinex 4 Team Approach

will assist with upgrading your front-of-house serving line by collaborating with you and your team to come up with efficient layouts for optimizing traffic flow, experience, food temperature and service needs.

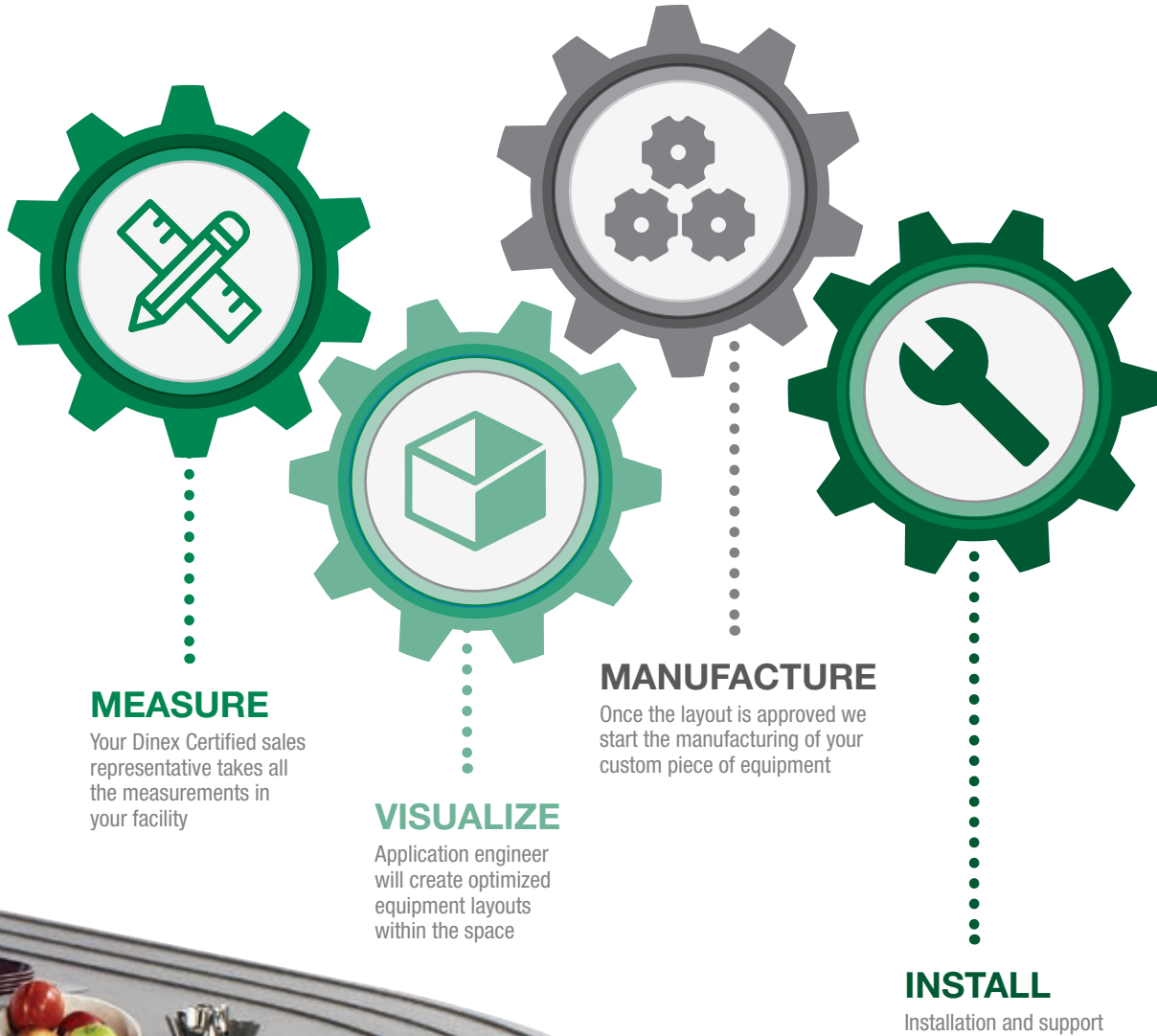

See the Dinex App for Application and Layout Examples

DINEXPRESS – MODULAR SYSTEM

The Designer Series of Modular Counters

DineXpress is the **perfect solution** for **front-of-house dining areas or back-of-house prep stations**. DineXpress counters offer a wide **variety** of options and accessories, from decorative sneeze guards to **customized** shelves, tray slides and cutouts.

DINEXPRESS®

Base models do not include optional accessories as shown in photos, please see pages 110-113 for additional details

Sneeze guard options are available with light and/or heat fixtures, and can be adjusted for self-serve or server style dining.



Access panels along base of unit can easily be removed to level unit.

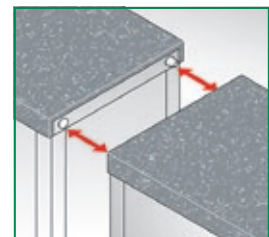

Counters are configured quickly, using the innovative EZ-Connect latching system. Attach or disconnect with a simple squeeze of the latch.

DineXpress Features Are Engineered To Make Your Job Easier



Open storage or under-shelf options for all size hot food counters.



EZ-Access panel; No need to remove the well for service as the heating elements slide out from underneath to allow access.



Heat-in-Base options available for maximum space and performance efficiency.



Optional Induction Counter Cooktop.



DineXpress Offers Front-Of-House Innovation

Increase employee and visitor traffic by creating an enticing destination. Increase check averages and reduce labor and food waste. If you are looking for a contemporary, completely customizable front-of-house meal serving solution look no further than DineXpress. DineXpress is designed for applications such as meat carving stations, salad bars, dessert bars, cashier stations and deli service counters in cafeterias and dining halls.

DineXpress counter styles and sizes range from a simple cashier stand to a customized buffet unit with cold well, soup wells, and self-leveling plate and tray dispensers.

Call your local Dinex sales rep for a site audit and customized drawing



Shown with Collapsible Solid Ribbed Tray Slide

Simple Front-Of-House Cashier's Station



Carving Counter

If an option is needed we can do it!



Choose from a virtually unlimited number of panel combinations, countertop materials and accessories to create an attractive and functional serving system for your cafeteria, conference area or buffet line.

DineXpress Gives You Back-Of-House Flexibility

If you are looking to upgrade your kitchen look no further than DineXpress. We can help you set up the perfect system based on your space requirements and serving style. Our extensive equipment offerings support traditional traylines, innovative POD systems, room service, and everything in between. **Let us help you build the fundamentals to higher patient and resident satisfaction.**



Back-Of-House Slim Line Hot Food Counter with Drop Down Work Shelf



DineXpress offers unlimited combinations of buffet line systems. "L" shaped and kiosk configurations are also available, with a wide selection of options and accessories.

DINEXPRESS – HOT FOOD COUNTERS

Hot Food Counters

- DineXpress Hot Food Counters are available in sizes from 2 to 6 wells and offer a wide variety of options and accessories
- Counters come standard with heavy-duty 5" casters (two locking) and are available with stainless steel base-skirting on three or four sides
- Stainless steel drop down work shelves are available for all configurations
- Intermediate under-shelf and open under counter storage are available for all hot food counters
- Easy access panel for fast and easy service of all heating elements and thermostats is standard
- NSF Listed



Shown with optional solid ribbed tray slide, sneeze guard and laminate panels.



Hot Food Counters with Heat-in-Base

- Heat-in-Base option offers maximum efficiency



Product Specifications Can Be Customized

All counter options must be ordered at the same time as the counter. See pages 110-113 for a complete list of options and accessories such as tray slides, end-shelf, base skirting, etc.



Shown with optional collapsible three-bar tray slide, adjustable sneeze guard, three-sided laminate panels and engineered stone top.



StorPlus Stainless Steel Food Pans

Complete your hot food counter set up with Stainless Steel Food Pans
page 201



StorPlus High Heat Food Pans

page 200

Prod No	Description	L x D x H	Watts / Amps	Pack
Hot Food Counters – 208 Volts / Single Phase				
DXDHF2 Δ	Hot Food Counter - 2 Well	35" x 30" x 36" / 88.9 x 76.2 x 91.4 cm	2000 / 9.6	1 ea
DXDHF3 Δ	Hot Food Counter - 3 Well	49" x 30" x 36" / 124.5 x 76.2 x 91.4 cm	3000 / 14.4	1 ea
DXDHF4 Δ	Hot Food Counter - 4 Well	63" x 30" x 36" / 160 x 76.2 x 91.4 cm	4000 / 19.2	1 ea
DXDHF5 Δ	Hot Food Counter - 5 Well	77" x 30" x 36" / 195.6 x 76.2 x 91.4 cm	5000 / 24.1	1 ea
DXDHF6 Δ	Hot Food Counter - 6 Well	91" x 30" x 36" / 231.1 x 76.2 x 91.4 cm	6000 / 28.8	1 ea
Hot Food Counters with Heat-in-Base – 208 Volts / Single Phase				
DXDHF2HIB	Hot Food Counter - 2 Well with Heat-in-Base	35" x 30" x 36" / 88.9 x 76.2 x 91.4 cm	2350 / 11.3	1 ea
DXDHF3HIB	Hot Food Counter - 3 Well with Heat-in-Base	49" x 30" x 36" / 124.5 x 76.2 x 91.4 cm	3550 / 17.1	1 ea
DXDHF4HIB	Hot Food Counter - 4 Well with Heat-in-Base	63" x 30" x 36" / 160 x 76.2 x 91.4 cm	4700 / 22.6	1 ea
DXDHF5HIB	Hot Food Counter - 5 Well with Heat-in-Base	77" x 30" x 36" / 195.6 x 76.2 x 91.4 cm	5900 / 28.4	1 ea
DXDHF6HIB	Hot Food Counter - 6 Well with Heat-in-Base	91" x 30" x 36" / 231.1 x 76.2 x 91.4 cm	7100 / 34.1	1 ea

DineXpress by CFS Brands NSF Listed products are designated with a **Δ** and may be prefixed with an N

Hot Top Counters

- DineXpress Hot Top Counters are available in 2 to 6 "well" lengths and offer a large variety of options and accessories
- Counters come standard with heavy-duty 5" casters (two locking) and are available with stainless steel base-skirting on three or four sides
- Stainless steel drop down work shelves are available for all configurations
- NSF Listed

Shown with collapsible three-bar tray slide, adjustable sneeze guard, laminate panels, and drop down end shelf.



All DineXpress counters are offered with options for adjustable casters and a variety of other options.



Hot Top Counters with Heat-in-Base

- Versatile hot top serving counter features extra storage capacity for pans or pre-packaged hot foods with the Heat-in-Base under counter cabinet
- Serve hot foods quickly and efficiently on the hot top, complete with optional gantry heat & light fixture
- Extra food storage capacity reduces wait time and increases guest satisfaction by not running out of food



Product Specifications Can Be Customized

Stainless steel counter tops and side panels are standard. A variety of optional counter top materials and side laminate panels are available. See page 108 for more information.



Measure Misers
page 192

Prod No	Description	L x D x H	Watts / Amps	Pack
Hot Top Counters – 120 Volts				
DXDHT2 Δ	Hot Top Counter - 2 Well	35" x 30" x 36" / 88.9 x 76.2 x 91.4 cm	145 / 1.2	1 ea
DXDHT3 Δ	Hot Top Counter - 3 Well	49" x 30" x 36" / 124.5 x 76.2 x 91.4 cm	250 / 2.1	1 ea
DXDHT4 Δ	Hot Top Counter - 4 Well	63" x 30" x 36" / 160 x 76.2 x 91.4 cm	350 / 2.9	1 ea
DXDHT5 Δ	Hot Top Counter - 5 Well	77" x 30" x 36" / 195.6 x 76.2 x 91.4 cm	450 / 3.8	1 ea
DXDHT6 Δ	Hot Top Counter - 6 Well	91" x 30" x 36" / 231.1 x 76.2 x 91.4 cm	550 / 4.6	1 ea
Hot Top Counters with Heat-in-Base - 208 Volts				
DXDHT2HIB	Hot Top Counter - 2 Well with Heat-in-Base	35" x 30" x 36" / 88.9 x 76.2 x 91.4 cm	495 / 2.9	1 ea
DXDHT3HIB	Hot Top Counter - 3 Well with Heat-in-Base	49" x 30" x 36" / 124.5 x 76.2 x 91.4 cm	800 / 4.8	1 ea
DXDHT4HIB	Hot Top Counter - 4 Well with Heat-in-Base	63" x 30" x 36" / 160 x 76.2 x 91.4 cm	1050 / 6.3	1 ea
DXDHT5HIB	Hot Top Counter - 5 Well with Heat-in-Base	77" x 30" x 36" / 195.6 x 76.2 x 91.4 cm	1350 / 8.2	1 ea
DXDHT6HIB	Hot Top Counter - 6 Well with Heat-in-Base	91" x 30" x 36" / 231.1 x 76.2 x 91.4 cm	1650 / 10	1 ea

Dinex by CFS Brands NSF Listed products are designated with a Δ and may be prefixed with an N



DINEXPRESS – HOT FOOD & SPECIALTY COUNTERS

Slim Line & L Shape Counters

- The slim line and the “L” shape counters provide easy access to both the hot food and the tray line for the tray assembly workers
- NSF Listed



Product Specifications Can Be Customized

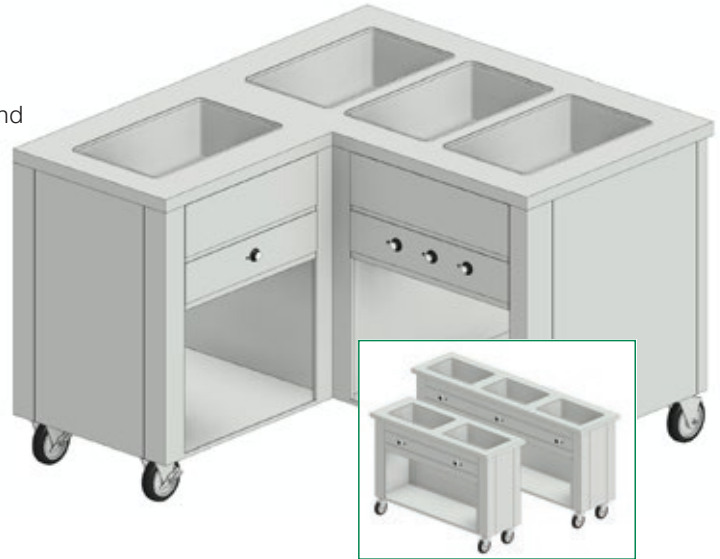

Shown with optional tray slide, sneeze guard, laminate panels, hinged door for base and engineered stone top



Hot/Cold Food Counters

- **Hot or cold food presentation in one unit (can be used either all hot or all cold but not at the same time)**
- Offers professional appearance for food displays
- Versatile modular design allows you to custom design a cafeteria or buffet unit to fit your line-up choosing only the options and accessories that you want and need
- DineXpress units will interlock with other DineXpress units
- NSF Listed

Shown with hinged door option and NSF7 adjustable sneeze guard

Prod No	Description	L x D x H	Watts / Amps	Pack
Specialty Counters – 208 Volts / Single Phase				
DXDHF2SL Δ	Slim Line Hot Food - 2 Well	53" x 19" x 36" / 134.7 x 48.3 x 91.4 cm	2000 / 9.6	1 ea
DXDHF3SL Δ	Slim Line Hot Food - 3 Well	77" x 19" x 36" / 195.6 x 48.3 x 91.4 cm	3000 / 14.4	1 ea
DXDHF3LL Δ	"L" Shape Hot Food, Left - 3 Well	35" x 55.25" x 36" / 88.9 x 140.3 x 91.4 cm	3000 / 14.4	1 ea
DXDHF3LR Δ	"L" Shape Hot Food, Right - 3 Well	35" x 55.25" x 36" / 88.9 x 140.3 x 91.4 cm	3000 / 14.4	1 ea
DXDHF4LL Δ	"L" Shape Hot Food, Left - 4 Well	49" x 55.25" x 36" / 124.5 x 140.3 x 91.4 cm	4000 / 19.2	1 ea
DXDHF4LR Δ	"L" Shape Hot Food, Right - 4 Well	49" x 55.25" x 36" / 124.5 x 140.3 x 91.4 cm	4000 / 19.2	1 ea
DXDHF5LL Δ	"L" Shape Hot Food, Left - 5 Well	63" x 55.25" x 36" / 160 x 140.3 x 91.4 cm	5000 / 24.1	1 ea
DXDHF5LR Δ	"L" Shape Hot Food, Right - 5 Well	63" x 55.25" x 36" / 160 x 140.3 x 91.4 cm	5000 / 24.1	1 ea

Prod No	Description	L x D x H	Amps Cold	Amps Hot	Pack
Hot / Cold Food Counters - 120 / 208 Volts					
DXDHC2 Δ	Hot/Cold Food Counter - 2 Well	35" x 30" x 36" / 88.9 x 76.2 x 91.4 cm	7.2	9.6	1 ea
DXDHC3 Δ	Hot/Cold Food Counter - 3 Well	49" x 30" x 36" / 124.5 x 76.2 x 91.4 cm	7.2	14.4	1 ea
DXDHC4 Δ	Hot/Cold Food Counter - 4 Well	63" x 30" x 36" / 160 x 76.2 x 91.4 cm	7.2	19.2	1 ea
DXDHC5 Δ	Hot/Cold Food Counter - 5 Well	77" x 30" x 36" / 195.6 x 76.2 x 91.4 cm	8.8	24	1 ea
DXDHC6 Δ	Hot/Cold Food Counter - 6 Well	91" x 30" x 36" / 231.1 x 76.2 x 91.4 cm	8.8	28.8	1 ea

DineXpress by CFS Brands NSF Listed products are designated with a Δ and may be prefixed with an N
 Note: Hot/Cold Food counters can be run all hot or all cold but not both hot and cold at the same time.

Cold Food Counters

- Available from 2 to 6 wells
- **Cold food counters are the most versatile and adaptable accessory on the serving line**
- Counters are mobile with heavy-duty 5" casters (two locking) with stainless steel base-skirting available
- Stainless or custom drop down shelves and tray slides available for all configurations



All counter options must be ordered at the same time as the counter. See pages 110-113 for a complete list of optional accessories such as tray slides, end-shelf, skirting, etc.



Shown with optional tray slide, sneeze guard, laminate panels and engineered stone top and skirting

Frost Top Counters

- Decrease wait time and increase guest satisfaction by offering grab and go entrées from our Frost Top
- Ideal for salads, desserts or cold beverage cartons
- Versatile and efficient part of the serving line
- Frost top has a 1" recessed well and a 1" drain with a shut-off valve
- Available in 2 to 6 well lengths, with the same unique choices for design and options such as food protectors, cold storage base and skirting
- NSF Listed



Product Specifications
Can Be Customized

Prod No	Description	L x D x H	Pack
Frost Top Cold Food Counters – 120 Volts / Single Phase / 7 Amps			
DXDFT2 Δ	Frost Top Cold Food Counter - 2 Well	35" x 30" x 36" / 88.9 x 76.2 x 91.4 cm	1 ea
DXDFT3 Δ	Frost Top Cold Food Counter - 3 Well	49" x 30" x 36" / 124.5 x 76.2 x 91.4 cm	1 ea
DXDFT4 Δ	Frost Top Cold Food Counter - 4 Well	63" x 30" x 36" / 160 x 76.2 x 91.4 cm	1 ea
DXDFT5 Δ	Frost Top Cold Food Counter - 5 Well	77" x 30" x 36" / 195.6 x 76.2 x 91.4 cm	1 ea
DXDFT6 Δ	Frost Top Cold Food Counter - 6 Well	91" x 30" x 36" / 231.1 x 76.2 x 91.4 cm	1 ea

Dinex by CFS Brands NSF Listed products are designated with a Δ and may be prefixed with an N



DINEXPRESS COLD FOOD & SPECIALTY COUNTERS



Shown with adjustable sneeze guard, tray slide, laminate panels and engineered stone top.

Cold Food Counters

- **Excellent for serving chilled fruit, drinks, salads, and desserts**
- Available from 2 to 6 wells
- Counters come standard with heavy-duty 5" casters (two locking) with stainless steel base-skirting available
- Stainless or custom drop down shelves and tray slides available for all configurations
- Electric refrigerated and ice well units available
- Feature 5" or 9.44" deep wells (NSF7)
- Stainless sneeze guards
- Cold Storage Base available
- Under-shelf options
- Most units are NSF Listed, see product chart for details



Product Specifications Can Be Customized

Carving Counters

- **State-of-the art upgrade to your serving counter system**
- Ideal for meat carving, with cutting board, roast skewer, drip pan and overhead heat lamp
- Under counter storage and optional shelves available



Prod No	Description	L x D x H	Pack
---------	-------------	-----------	------

Refrigerated Food Counters with 9.44" Deep Wells - 120 Volts / Single Phase / 7 Amps (NSF7)

DXDCF27 ◊	Cold Food Counter - 2 Well	35" x 30" x 36" / 88.9 x 76.2 x 91.4 cm	1 ea
DXDCF37 ◊	Cold Food Counter - 3 Well	49" x 30" x 36" / 124.5 x 76.2 x 91.4 cm	1 ea
DXDCF47 ◊	Cold Food Counter - 4 Well	63" x 30" x 36" / 160 x 76.2 x 91.4 cm	1 ea
DXDCF57 ◊	Cold Food Counter - 5 Well	77" x 30" x 36" / 195.6 x 76.2 x 91.4 cm	1 ea
DXDCF67 ◊	Cold Food Counter - 6 Well	91" x 30" x 36" / 231.1 x 76.2 x 91.4 cm	1 ea

Refrigerated Food Counters with 5" Deep Wells - 120 Volts / Single Phase / 7 Amps

DXDCF2 Δ	Cold Food Counter - 2 Well	35" x 30" x 36" / 88.9 x 76.2 x 91.4 cm	1 ea
DXDCF3 Δ	Cold Food Counter - 3 Well	49" x 30" x 36" / 124.5 x 76.2 x 91.4 cm	1 ea
DXDCF4 Δ	Cold Food Counter - 4 Well	63" x 30" x 36" / 160 x 76.2 x 91.4 cm	1 ea
DXDCF5 Δ	Cold Food Counter - 5 Well	77" x 30" x 36" / 195.6 x 76.2 x 91.4 cm	1 ea
DXDCF6 Δ	Cold Food Counter - 6 Well	91" x 30" x 36" / 231.1 x 76.2 x 91.4 cm	1 ea

Cold Food Counters (Ice Bath)

DXDCF2NR Δ	Cold Food Counter - 2 Ice Well	35" x 30" x 36" / 88.9 x 76.2 x 91.4 cm	1 ea
DXDCF3NR Δ	Cold Food Counter - 3 Ice Well	49" x 30" x 36" / 124.5 x 76.2 x 91.4 cm	1 ea
DXDCF4NR Δ	Cold Food Counter - 4 Ice Well	63" x 30" x 36" / 160 x 76.2 x 91.4 cm	1 ea
DXDCF5NR Δ	Cold Food Counter - 5 Ice Well	77" x 30" x 36" / 195.6 x 76.2 x 91.4 cm	1 ea
DXDCF6NR Δ	Cold Food Counter - 6 Ice Well	91" x 30" x 36" / 231.1 x 76.2 x 91.4 cm	1 ea

Meat Carving Counter

DXDMC2	Meat Carving Counter with Cutting Board, Heat Lamp, Drip Pan	35" x 30" x 36" / 88.9 x 76.2 x 91.4 cm	1 ea
--------	--	---	------

Dinex by CFS Brands NSF 7 Listed products are designated with a ◊

Dinex by CFS Brands NSF Listed products are designated with a Δ and may be prefixed with an N

Solid Top Counters

- **DineXpress Corner Counters are the perfect complement for completing complex counter system layouts**
- Corner counters come in 45° and 90° configurations and will interlock with other DineXpress counters
- Solid Top Counters are available from 35" to 91" in length with a wide choice of optional top surfaces and virtually unlimited selection of panel laminates
- Optional tray slides and shelves can be added to complete this unit
- These counters come standard with heavy-duty 5" casters (two locking)
- Some units are NSF Listed see product chart for details



Shown with laminate panels and tray slide options



**Product Specifications
Can Be Customized**

All counter options must be ordered at the same time as the counter. See pages 110-113 for a complete list of optional accessories such as tray slides, drop down end-shelf, base skirting, etc.

Cashier Stands/Solid Top Counters

- Cashier's stand with open storage compartment and optional drawer
- NSF Listed



Proex Disposables

page 54

Urn Stands/Beverage Counter

- **DineXpress Urn Stands are built to hold any configuration of fountain machines, ice makers and coffee bars**
- Available with under-counter storage for supplies and custom "bag and box," along with any configuration of tray slides and skirting
- Feature the unique EZ-Connect latching system
- NSF Listed



Shown with laminate panels, tray slide options, hinged door

Prod No	Description	L x D x H	Pack
Solid Top Counters			
DXDST2 Δ	35" Solid Top Counter	35" x 30" x 36" / 88.9 x 76.2 x 91.4 cm	1 ea
DXDST3 Δ	49" Solid Top Counter	49" x 30" x 36" / 124.5 x 76.2 x 91.4 cm	1 ea
DXDST4 Δ	63" Solid Top Counter	63" x 30" x 36" / 160 x 76.2 x 91.4 cm	1 ea
DXDST5 Δ	77" Solid Top Counter	77" x 30" x 36" / 195.6 x 76.2 x 91.4 cm	1 ea
DXDST6 Δ	91" Solid Top Counter	91" x 30" x 36" / 231.1 x 76.2 x 91.4 cm	1 ea
Corner Counters			
DXDCR45	Corner Counter with 45° Cabinet	30" x 30" x 36" / 76.2 x 76.2 x 91.4 cm	1 ea
DXDCR90	Corner Counter with 90° Cabinet	30" x 30" x 36" / 76.2 x 76.2 x 91.4 cm	1 ea
Cashier Stands			
DXDCS Δ	Cashier Stand without Drawer	30" x 30" x 36" / 76.2 x 76.2 x 91.4 cm	1 ea
DXDCSD Δ	Cashier Stand with Drawer	30" x 30" x 36" / 76.2 x 76.2 x 91.4 cm	1 ea
Beverage Urn Stands			
DXDUS2 Δ	35" Beverage Urn Stand	35" x 30" x 36" / 88.9 x 76.2 x 91.4 cm	1 ea
DXDUS3 Δ	49" Beverage Urn Stand	49" x 30" x 36" / 124.5 x 76.2 x 91.4 cm	1 ea
DXDUS4 Δ	63" Beverage Urn Stand	63" x 30" x 36" / 160 x 76.2 x 91.4 cm	1 ea
DXDUS5 Δ	77" Beverage Urn Stand	77" x 30" x 36" / 195.6 x 76.2 x 91.4 cm	1 ea
DXDUS6 Δ	91" Beverage Urn Stand	91" x 30" x 36" / 231.1 x 76.2 x 91.4 cm	1 ea

Dinex by CFS Brands NSF Listed products are designated with a **Δ** and may be prefixed with an N



DINEXPRESS FRONT-OF-HOUSE CUSTOMIZATION DESIGNED TO DELIGHT YOUR GUESTS



Shown with laminate panel options, tray slide, adjustable sneeze guard and engineered stone top.



Laminated Panels

- All DineXpress counters offer selections of contemporary counter surfaces and panel graphics
- Choose from a large number of panel laminates, textures, countertop materials and accessories to create an attractive and functional serving system for your cafeteria, conference area and/or buffet line
- Choose from any standard level Wilsonart* laminate. Premium designs are available at additional cost



Product Specifications Can Be Customized

Specialty Counter Tops

- Ask about custom counter tops in a wide selection of acrylic or engineered stone
- End shelves and tray slides are also available in the same custom materials



Prod No **Description**

Pack

Laminated Panels

DXFLP2	Wilsonart Laminate Panels , 3 Sided - 2 Well	1 ea
DXFLP3	Wilsonart Laminate Panels, 3 Sided - 3 Well	1 ea
DXFLP4	Wilsonart Laminate Panels, 3 Sided - 4 Well	1 ea
DXFLP5	Wilsonart Laminate Panels, 3 Sided - 5 Well	1 ea
DXFLP6	Wilsonart Laminate Panels, 3 Sided - 6 Well	1 ea
DXFLP42	Wilsonart Laminate Panels, 4 Sided - 2 Well	1 ea
DXFLP43	Wilsonart Laminate Panels, 4 Sided - 3 Well	1 ea
DXFLP44	Wilsonart Laminate Panels, 4 Sided - 4 Well	1 ea
DXFLP45	Wilsonart Laminate Panels, 4 Sided - 5 Well	1 ea
DXFLP46	Wilsonart Laminate Panels, 4 Sided - 6 Well	1 ea

Laminated Panels for Doors

DXFLPD2	Wilsonart Laminate Panels for Hinged Door - 2 Well, 1 Door	1 ea
DXFLPD3	Wilsonart Laminate Panels for Hinged Door - 3 Well, 2 Doors	1 ea
DXFLPD4	Wilsonart Laminate Panels for Hinged Door - 4 Well, 4 Doors	1 ea
DXFLPD5	Wilsonart Laminate Panels for Hinged Door - 5 Well, 4 Doors	1 ea
DXFLPD6	Wilsonart Laminate Panels for Hinged Door - 6 Well, 4 Doors	1 ea

* Wilsonart is a registered trademark. DineX is not associated in any way with Wilsonart.

DINEXPRESS SPECIALTY PRODUCTS

Ice Cream Freezer

- Freezer unit keeps ice cream and frozen desserts at the proper temperature
- Ideal for freezing our Cool Base to ensure patient satisfaction for all of your cold foods
- Hinged top opening allows easy access to treats
- NSF Listed



DXDICF

Milk Cooler

- Refrigerated unit keeps milk and other cold drinks at the proper temperature
- Fits standard milk crates for easy cleaning and restocking which saves labor
- Hinged top opening allows easy access
- NSF Listed



DXDMC



**Product Specifications
Can Be Customized**

Stainless steel counter tops and panels are standard. A variety of optional counter top materials and laminate panels are available. See page 108 for more information.

Combine these products with your DineXpress to offer a complete solution



Dinnerware
page 162

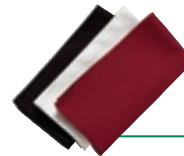

Marko Napkins
page 177



Measure Misers
page 192



Marko Embrace
page 176

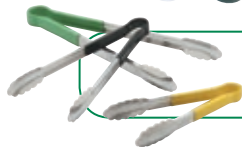

Tongs
page 193



Coldmaster
page 208

Prod No	Description	L x D x H	Volt	Pack
Ice Cream Freezer				
DXDICF Δ	Ice Cream Freezer, 5 Cubic Feet	49" x 30" x 36" / 124.5 x 76.2 x 91.4 cm	120V 7 amps	1 ea
Milk Cooler				
DXDMC Δ	Milk Cooler, 5 Cubic Feet	49" x 30" x 36" / 124.5 x 76.2 x 91.4 cm	—	1 ea

Dinex by CFS Brands NSF Listed products are designated with a Δ and may be prefixed with an N

DINEXPRESS ACCESSORIES

Manifold Drain



Solid Ribbed Tray Slide



Drop Down Work Shelf



3-Bar Tray Slide



All options and accessories must be ordered at the same time as the counter

Prod No	Description	Pack
Fill Accessories for Hot Food Counters		
DXDHAF	Auto-Fill for Hot Food Counters	1 ea
Manifold Drains for Hot Food Counters - Requires (1) Manifold Drain Per Well		
DXMD2	Manifold Drain - 2 Well	1 ea
DXMD3	Manifold Drain - 3 Well	1 ea
DXMD4	Manifold Drain - 4 Well	1 ea
DXMD5	Manifold Drain - 5 Well	1 ea
DXMD6	Manifold Drain - 6 Well	1 ea
DXMDEDRN	Electric Drain, 208v for Hot Food Counters	1 ea
DXMDID	Shut-Off Valve for Individual Drain - requires (1) per well	1 ea
Solid Ribbed Tray Slides		
DXTSSR2	12" Solid Ribbed Tray Slide - 2 Well	1 ea
DXTSSR3	12" Solid Ribbed Tray Slide - 3 Well	1 ea
DXTSSR4	12" Solid Ribbed Tray Slide - 4 Well	1 ea
DXTSSR5	12" Solid Ribbed Tray Slide - 5 Well	1 ea
DXTSSR6	12" Solid Ribbed Tray Slide - 6 Well	1 ea
3-Bar Tray Slides		
DXTS3B2	12" 3-Bar Tray Slide - 2 Well	1 ea
DXTS3B3	12" 3-Bar Tray Slide - 3 Well	1 ea
DXTS3B4	12" 3-Bar Tray Slide - 4 Well	1 ea
DXTS3B5	12" 3-Bar Tray Slide - 5 Well	1 ea
DXTS3B6	12" 3-Bar Tray Slide - 6 Well	1 ea
Drop Down Work Shelf		
DXDDWS2	8" Drop Down Work Shelf - 2 Well	1 ea
DXDDWS3	8" Drop Down Work Shelf - 3 Well	1 ea
DXDDWS4	8" Drop Down Work Shelf - 4 Well	1 ea
DXDDWS5	8" Drop Down Work Shelf - 5 Well	1 ea
DXDDWS6	8" Drop Down Work Shelf - 6 Well	1 ea



Intermediate Under Shelf



Hinged Door for Base



Refrigerated Base



Cold-In-Base



Cutout for Drop-Ins



Legs for Stationary Counters

Prod No	Description	Pack
Intermediate Under Shelf		
DXINTS2	Intermediate Under Shelf - 2 Well	1 ea
DXINTS3	Intermediate Under Shelf - 3 Well	1 ea
DXINTS4	Intermediate Under Shelf - 4 Well	1 ea
DXINTS5	Intermediate Under Shelf - 5 Well	1 ea
DXINTS6	Intermediate Under Shelf - 6 Well	1 ea
Hinged Door for Base		
DXHD2	Hinged Door for Base - 2 Well	1 ea
DXHD3	Hinged Door for Base - 3 Well	1 ea
DXHD4	Hinged Door for Base - 4 Well	1 ea
DXHD5	Hinged Door for Base - 5 Well	1 ea
DXHD6	Hinged Door for Base - 6 Well	1 ea
Refrigerated Base for Cold Counters		
DXRB1D	Refrigerated Base 1-Door fits DXDCF4, DXDCF47, DXDFT4, DXDCF4NR and DXDST4	1 ea
DXRB2D	Refrigerated Base 2-Door fits DXDCF5, DXDCF57, DXDFT5, DXDCF5NR, DXDST5, DXDCF6, DXDCF67	1 ea
Cold-in-Base for Cold Food Counters		
DXCIB	Cold-in-Base with 2 Cold Packs	1 ea
Cutout for Drop-Ins		
DXCUT	Cutout for Drop-Ins	1 ea
Legs for Stationary Counters		
DXLEGS2-4	6" Legs in Lieu of Casters For 2, 3, and 4 Well Units	1 ea
DXLEGS2-6	6" Legs in Lieu of Casters For 5 and 6 Well Units	1 ea
Adjustable Caster Upgrades		
DXAC54	Adjustable Caster Upgrade, Four 5" Casters; 2 with brakes - 2-4 Well	1 set
DXAC56	Adjustable Caster Upgrade, Six 5" Casters; 2 with brakes - 5-6 Well	1 set
Skirting – Optional Base Panels to Hide Casters or Legs		
DXSKR2	Skirting, 3 Sided - 2 Well	1 ea
DXSKR3	Skirting, 3 Sided - 3 Well	1 ea
DXSKR4	Skirting, 3 Sided - 4 Well	1 ea
DXSKR5	Skirting, 3 Sided - 5 Well	1 ea
DXSKR6	Skirting, 3 Sided - 6 Well	1 ea
DXSKR42	Skirting, 4 Sided - 2 Well	1 ea
DXSKR43	Skirting, 4 Sided - 3 Well	1 ea
DXSKR44	Skirting, 4 Sided - 4 Well	1 ea
DXSKR45	Skirting, 4 Sided - 5 Well	1 ea
DXSKR46	Skirting, 4 Sided - 6 Well	1 ea

DINEXPRESS ACCESSORIES



Duplex Outlet



Soup Well

All options and accessories must be ordered at the same time as the counter

Prod No	Description	Pack
Duplex Outlet		
DXDOUT	Duplex Outlet	1 ea
Specialty Counter Tops Accessories - Drop-In Soup Wells		
DXDSW7	Drop-In Soup Well, 7 Quart	1 ea
DXDSW7D	Drop-In Soup Well, 7 Quart with Drain	1 ea
DXDSW7T	Drop-In Soup Well, 7 Quart Thermostatically Controlled	1 ea
DXDSW7TD	Drop-In Soup Well, 7 Quart Thermostatically Controlled with Drain	1 ea
DXDSW11	Drop-In Soup Well, 11 Quart	1 ea
DXDSW11D	Drop-In Soup Well, 11 Quart with Drain	1 ea
DXDSW11T	Drop-In Soup Well, 11 Quart Thermostatically Controlled	1 ea
DXDSW11TD	Drop-In Soup Well, 11 Quart Thermostatically Controlled with Drain	1 ea
Specialty Counter Tops Accessories - Soup Well Adapters & Inserts		
DXSWA7	Adapter Turns 12" x 20" Well into Two 7 Quart Wells	1 ea
DXSWA711	Adapter Turns 12" x 20" Well into One 7 Quart Well and One 11 Quart Well	1 ea
DXSWI7	7 Quart Round Insert with Lid	1 ea
DXSWI11	11 Quart Round Insert with Lid	1 ea
Specialty Counter Tops Accessories - Universal Top for Hot Food Units		
DXRUT3	Recessed Universal Top for 12" x 20" & 18" x 26" Pans - 3 Well	1 ea
DXRUT4	Recessed Universal Top for 12" x 20" & 18" x 26" Pans - 4 Well	1 ea
DXRUT5	Recessed Universal Top for 12" x 20" & 18" x 26" Pans - 5 Well	1 ea
DXRUT6	Recessed Universal Top for 12" x 20" & 18" x 26" Pans - 6 Well	1 ea
Specialty Counter Tops Accessories - Correctional Options		
DXLCFC	Locking Cover for Controls	1 ea
DXTFPF	Tamper Proof Fastener Package	1 ea
Specialty Counter Tops Accessories - Stainless Steel Push Handles		
DXSSPH	Stainless Steel Push-Handle for Counters	1 ea
Specialty Counter Tops Accessories - Grab Bars (Wheel Chair Assist)		
DXGB2	Grab Bar for Counter - 2 Well	1 ea
DXGB3	Grab Bar for Counter - 3 Well	1 ea
DXGB4	Grab Bar for Counter - 4 Well	1 ea
DXGB5	Grab Bar for Counter - 5 Well	1 ea
DXGB6	Grab Bar for Counter - 6 Well	1 ea



Overhead Shelf

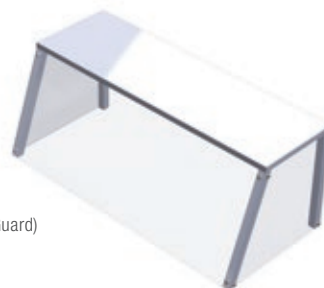

Food Protector (Sneeze Guard)

Prod No	Description	Pack
Over Head Shelf		
DXOHS2	Over Head Shelf - 2 Well	1 ea
DXOHS3	Over Head Shelf - 3 Well	1 ea
DXOHS4	Over Head Shelf - 4 Well	1 ea
DXOHS5	Over Head Shelf - 5 Well	1 ea
DXOHS6	Over Head Shelf - 6 Well	1 ea
Full Service Protector Guards (Café Style)		
DXFSG2	Full Service Guard - 2 Well	1 ea
DXFSG3	Full Service Guard - 3 Well	1 ea
DXFSG4	Full Service Guard - 4 Well	1 ea
DXFSG5	Full Service Guard - 5 Well	1 ea
DXFSG6	Full Service Guard - 6 Well	1 ea
Full Service Protector Guards (Café Style) with Fluorescent Lights		
DXFSGFL2	Full Service Guard - 2 Well with Fluorescent Lights	1 ea
DXFSGFL3	Full Service Guard - 3 Well with Fluorescent Lights	1 ea
DXFSGFL4	Full Service Guard - 4 Well with Fluorescent Lights	1 ea
DXFSGFL5	Full Service Guard - 5 Well with Fluorescent Lights	1 ea
DXFSGFL6	Full Service Guard - 6 Well with Fluorescent Lights	1 ea
Full Service Protector Guards (Café Style) with Incandescent Lights		
DXFSGL2	Full Service Guard - 2 Well with Incandescent Lights	1 ea
DXFSGL3	Full Service Guard - 3 Well with Incandescent Lights	1 ea
DXFSGL4	Full Service Guard - 4 Well with Incandescent Lights	1 ea
DXFSGL5	Full Service Guard - 5 Well with Incandescent Lights	1 ea
DXFSGL6	Full Service Guard - 6 Well with Incandescent Lights	1 ea
Full Service Protector Guards (Café Style) with Heat & Lights		
DXFSGHL2	Full Service Guard - 2 Well with Heat & Lights	1 ea
DXFSGHL3	Full Service Guard - 3 Well with Heat & Lights	1 ea
DXFSGHL4	Full Service Guard - 4 Well with Heat & Lights	1 ea
DXFSGHL5	Full Service Guard - 5 Well with Heat & Lights	1 ea
DXFSGHL6	Full Service Guard - 6 Well with Heat & Lights	1 ea
Full Service Protector Guards (Café Style) with Heat		
DXFSGH2	Full Service Guard - 2 Well with Heat	1 ea
DXFSGH3	Full Service Guard - 3 Well with Heat	1 ea
DXFSGH4	Full Service Guard - 4 Well with Heat	1 ea
DXFSGH5	Full Service Guard - 5 Well with Heat	1 ea
DXFSGH6	Full Service Guard - 6 Well with Heat	1 ea
Full Service Protector Guard Option		
DXFSEG	End Guard for Full Service Protector Guards	1 ea

ADJUSTABLE GUARDS

The **only NSF Listed sneeze guard** for both **crew and self-serve** applications.

- **Fully adjustable**
- Works with self-serve and server-style dining; one unit can be adjusted for both applications during different parts of the day
- Made of clear, break-resistant polycarbonate
- Available with or without lights, with or without heat or with a combination of both
- NSF Listed



DXD3VP



DXD445P

All options and accessories must be ordered at the same time as the counter

Prod No	Description	L x D x H	Pack
Vertical Adjustable Guard			
DXD2VP ▲◆	2 Well	33.88" x 19.13" x 25.69" / 86.04 x 48.58 x 65.25 cm	1 ea
DXD3VP ▲◆	3 Well	47.88" x 19.13" x 25.69" / 121.60 x 48.58 x 65.25 cm	1 ea
DXD4VP ▲◆	4 Well	61.88" x 19.13" x 25.69" / 157.16 x 48.58 x 65.25 cm	1 ea
DXD5VP ▲◆	5 Well	75.88" x 19.13" x 25.69" / 192.72 x 48.58 x 65.25 cm	1 ea
DXD6VP ▲◆	6 Well	89.88" x 19.13" x 25.69" / 228.28 x 48.58 x 65.25 cm	1 ea
DXD4VPDT ▲◆	4 Well for Acrylic and Engineered Stone Tops	61.88" x 19.13" x 25.69" / 157.16 x 48.58 x 65.25 cm	1 ea
DXD5VPDT ▲◆	5 Well for Acrylic and Engineered Stone Tops	75.88" x 19.13" x 25.69" / 192.72 x 48.58 x 65.25 cm	1 ea
DXD6VPDT ▲◆	6 Well for Acrylic and Engineered Stone Tops	89.88" x 19.13" x 25.69" / 228.28 x 48.58 x 65.25 cm	1 ea
45 Degree Adjustable Guard			
DXD245P ▲◆	2 Well	33.88" x 19.13" x 28.19" / 86.04 x 48.58 x 71.60 cm	1 ea
DXD345P ▲◆	3 Well	47.88" x 19.13" x 28.19" / 121.60 x 48.58 x 71.60 cm	1 ea
DXD445P ▲◆	4 Well	61.88" x 19.13" x 28.19" / 157.16 x 48.58 x 71.60 cm	1 ea
DXD545P ▲◆	5 Well	75.88" x 19.13" x 28.19" / 192.72 x 48.58 x 71.60 cm	1 ea
DXD645P ▲◆	6 Well	89.88" x 19.13" x 28.19" / 228.28 x 48.58 x 71.60 cm	1 ea
DXD445PDT ▲◆	4 Well for Acrylic and Engineered Stone Tops	61.88" x 19.13" x 28.19" / 157.16 x 48.58 x 71.60 cm	1 ea
DXD545PDT ▲◆	5 Well for Acrylic and Engineered Stone Tops	75.88" x 19.13" x 28.19" / 192.72 x 48.58 x 71.60 cm	1 ea
DXD645PDT ▲◆	6 Well for Acrylic and Engineered Stone Tops	89.88" x 19.13" x 28.19" / 228.28 x 48.58 x 71.60 cm	1 ea

Dinex by CFS Brands NSF Listed products are designated with a ▲ and may be prefixed with an N

◆ California Residents: Bisphenol A **WARNING:** See appendix A on page 281

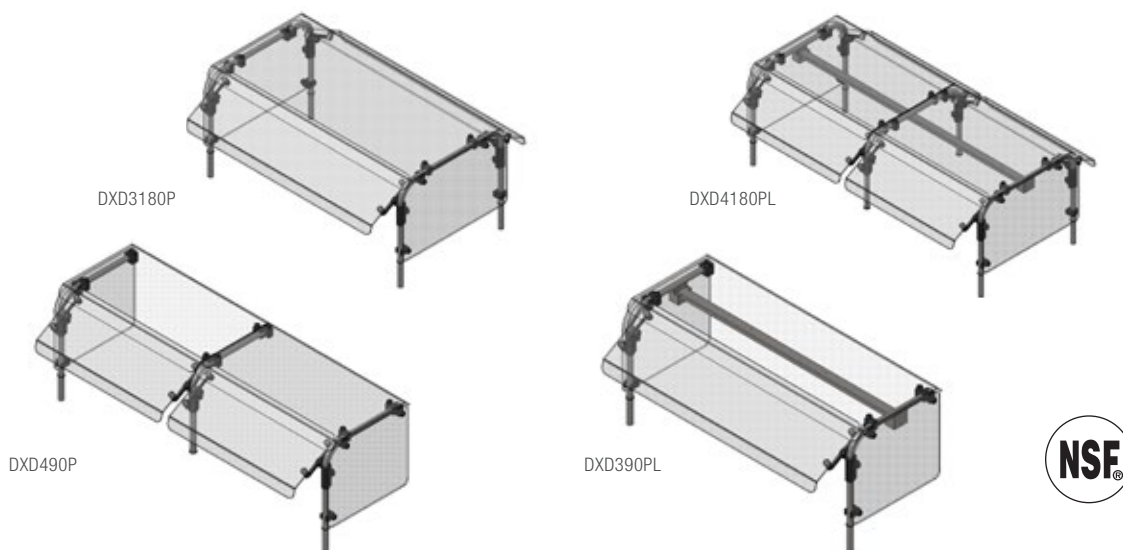

Prod No	Description	L x D x H	Pack
90 Degree Adjustable Guard			
DXD290P Δ \blacklozenge	2 Well	33.88" x 25.38" x 21.50" / 86.04 x 64.45 x 54.61 cm	1 ea
DXD390P Δ \blacklozenge	3 Well	47.88" x 25.38" x 21.50" / 121.60 x 64.45 x 54.61 cm	1 ea
DXD490P Δ \blacklozenge	4 Well	61.88" x 25.38" x 21.50" / 157.16 x 64.45 x 54.61 cm	1 ea
DXD590P Δ \blacklozenge	5 Well	75.88" x 25.38" x 21.50" / 192.72 x 64.45 x 54.61 cm	1 ea
DXD690P Δ \blacklozenge	6 Well	89.88" x 25.38" x 21.50" / 228.28 x 64.45 x 54.61 cm	1 ea
DXD490PDT Δ \blacklozenge	4 Well for Acrylic and Engineered Stone Tops	61.88" x 25.38" x 21.50" / 157.61 x 64.45 x 54.61 cm	1 ea
DXD590PDT Δ \blacklozenge	5 Well for Acrylic and Engineered Stone Tops	75.88" x 25.38" x 21.50" / 192.72 x 64.45 x 54.61 cm	1 ea
DXD690PDT Δ \blacklozenge	6 Well for Acrylic and Engineered Stone Tops	89.88" x 25.38" x 21.50" / 228.28 x 64.45 x 54.61 cm	1 ea
180 Degree Adjustable Guard			
DXD2180P Δ \blacklozenge	2 Well	33.88" x 37.81" x 22.00" / 86.04 x 96.04 x 55.88 cm	1 ea
DXD3180P Δ \blacklozenge	3 Well	47.88" x 37.81" x 22.00" / 121.60 x 96.04 x 55.88 cm	1 ea
DXD4180P Δ \blacklozenge	4 Well	61.88" x 37.81" x 22.00" / 157.16 x 96.04 x 55.88 cm	1 ea
DXD5180P Δ \blacklozenge	5 Well	75.88" x 37.81" x 22.00" / 192.72 x 96.04 x 55.88 cm	1 ea
DXD6180P Δ \blacklozenge	6 Well	89.88" x 37.81" x 22.00" / 228.28 x 96.04 x 55.88 cm	1 ea
DXD4180PDT Δ \blacklozenge	4 Well for Acrylic and Engineered Stone Tops	61.88" x 37.81" x 22.00" / 157.61 x 96.04 x 55.88 cm	1 ea
DXD5180PDT Δ \blacklozenge	5 Well for Acrylic and Engineered Stone Tops	75.88" x 37.81" x 22.00" / 192.72 x 96.04 x 55.88 cm	1 ea
DXD6180PDT Δ \blacklozenge	6 Well for Acrylic and Engineered Stone Tops	89.88" x 37.81" x 22.00" / 228.28 x 96.04 x 55.88 cm	1 ea
90 Degree Adjustable Guard with Fluorescent Lights			
DXD290PL Δ \blacklozenge	2 Well	33.88" x 25.38" x 21.50" / 86.04 x 64.45 x 54.61 cm	1 ea
DXD390PL Δ \blacklozenge	3 Well	47.88" x 25.38" x 21.50" / 121.60 x 64.45 x 54.61 cm	1 ea
DXD490PL Δ \blacklozenge	4 Well	61.88" x 25.38" x 21.50" / 157.16 x 64.45 x 54.61 cm	1 ea
DXD590PL Δ \blacklozenge	5 Well	75.88" x 25.38" x 21.50" / 192.72 x 64.45 x 54.61 cm	1 ea
DXD690PL Δ \blacklozenge	6 Well	89.88" x 25.38" x 21.50" / 228.28 x 64.45 x 54.61 cm	1 ea
DXD490PDTL Δ \blacklozenge	4 Well for Acrylic and Engineered Stone Tops	61.88" x 25.38" x 21.50" / 157.61 x 64.45 x 54.61 cm	1 ea
DXD590PDTL Δ \blacklozenge	5 Well for Acrylic and Engineered Stone Tops	75.88" x 25.38" x 21.50" / 192.72 x 64.45 x 54.61 cm	1 ea
DXD690PDTL Δ \blacklozenge	6 Well for Acrylic and Engineered Stone Tops	89.88" x 25.38" x 21.50" / 228.28 x 64.45 x 54.61 cm	1 ea
180 Degree Adjustable Guard with Fluorescent Lights			
DXD2180PL Δ \blacklozenge	2 Well	33.88" x 25.38" x 21.50" / 86.04 x 64.45 x 54.61 cm	1 ea
DXD3180PL Δ \blacklozenge	3 Well	47.88" x 25.38" x 21.50" / 121.60 x 64.45 x 54.61 cm	1 ea
DXD4180PL Δ \blacklozenge	4 Well	61.88" x 25.38" x 21.50" / 157.16 x 64.45 x 54.61 cm	1 ea
DXD5180PL Δ \blacklozenge	5 Well	75.88" x 25.38" x 21.50" / 192.72 x 64.45 x 54.61 cm	1 ea
DXD6180PL Δ \blacklozenge	6 Well	89.88" x 25.38" x 21.50" / 228.28 x 64.45 x 54.61 cm	1 ea
DXD4180PDTL Δ \blacklozenge	4 Well for Acrylic and Engineered Stone Tops	61.88" x 25.38" x 21.50" / 157.61 x 64.45 x 54.61 cm	1 ea
DXD5180PDTL Δ \blacklozenge	5 Well for Acrylic and Engineered Stone Tops	75.88" x 25.38" x 21.50" / 192.72 x 64.45 x 54.61 cm	1 ea
DXD6180PDTL Δ \blacklozenge	6 Well for Acrylic and Engineered Stone Tops	89.88" x 25.38" x 21.50" / 228.28 x 64.45 x 54.61 cm	1 ea

Dinex by CFS Brands NSF Listed products are designated with a Δ and may be prefixed with an N

\blacklozenge California Residents: Bisphenol A **WARNING:** See appendix A on page 281

ADJUSTABLE GUARDS

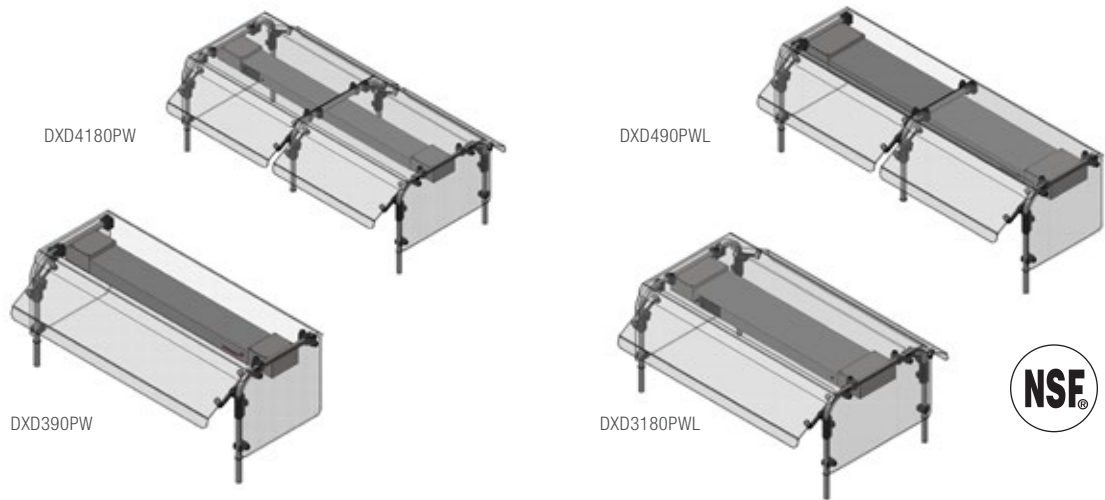

Prod No	Description	L x D x H	Pack
90 Degree Adjustable Guard with Warmer			
DXD290PW ▲ ◆	2 Well	33.88" x 25.38" x 21.50" / 86.04 x 64.45 x 54.61 cm	1 ea
DXD390PW ▲ ◆	3 Well	47.88" x 25.38" x 21.50" / 121.60 x 64.45 x 54.61 cm	1 ea
DXD490PW ▲ ◆	4 Well	61.88" x 25.38" x 21.50" / 157.16 x 64.45 x 54.61 cm	1 ea
DXD590PW ▲ ◆	5 Well	75.88" x 25.38" x 21.50" / 192.72 x 64.45 x 54.61 cm	1 ea
DXD690PW ▲ ◆	6 Well	89.88" x 25.38" x 21.50" / 228.28 x 64.45 x 54.61 cm	1 ea
DXD490PDTW ▲ ◆	4 Well for Acrylic and Engineered Stone Tops	61.88" x 25.38" x 21.50" / 157.61 x 64.45 x 54.61 cm	1 ea
DXD590PDTW ▲ ◆	5 Well for Acrylic and Engineered Stone Tops	75.88" x 25.38" x 21.50" / 192.72 x 64.45 x 54.61 cm	1 ea
DXD690PDTW ▲ ◆	6 Well for Acrylic and Engineered Stone Tops	89.88" x 25.38" x 21.50" / 228.28 x 64.45 x 54.61 cm	1 ea
180 Degree Adjustable Guard with Warmer			
DXD2180PW ▲ ◆	2 Well	33.88" x 37.81" x 22.00" / 86.04 x 96.04 x 55.88 cm	1 ea
DXD3180PW ▲ ◆	3 Well	47.88" x 37.81" x 22.00" / 121.60 x 96.04 x 55.88 cm	1 ea
DXD4180PW ▲ ◆	4 Well	61.88" x 37.81" x 22.00" / 157.16 x 96.04 x 55.88 cm	1 ea
DXD5180PW ▲ ◆	5 Well	75.88" x 37.81" x 22.00" / 192.72 x 96.04 x 55.88 cm	1 ea
DXD6180PW ▲ ◆	6 Well	89.88" x 37.81" x 22.00" / 228.28 x 96.04 x 55.88 cm	1 ea
DXD4180PDTW ▲ ◆	4 Well for Acrylic and Engineered Stone Tops	61.88" x 37.81" x 22.00" / 157.61 x 96.04 x 55.88 cm	1 ea
DXD5180PDTW ▲ ◆	5 Well for Acrylic and Engineered Stone Tops	75.88" x 37.81" x 22.00" / 192.72 x 96.04 x 55.88 cm	1 ea
DXD6180PDTW ▲ ◆	6 Well for Acrylic and Engineered Stone Tops	89.88" x 37.81" x 22.00" / 228.28 x 96.04 x 55.88 cm	1 ea
90 Degree Adjustable Guard with Warmer & Lights			
DXD290PWL ▲ ◆	2 Well	33.88" x 25.38" x 21.50" / 86.04 x 64.45 x 54.61 cm	1 ea
DXD390PWL ▲ ◆	3 Well	47.88" x 25.38" x 21.50" / 121.60 x 64.45 x 54.61 cm	1 ea
DXD490PWL ▲ ◆	4 Well	61.88" x 25.38" x 21.50" / 157.16 x 64.45 x 54.61 cm	1 ea
DXD590PWL ▲ ◆	5 Well	75.88" x 25.38" x 21.50" / 192.72 x 64.45 x 54.61 cm	1 ea
DXD690PWL ▲ ◆	6 Well	89.88" x 25.38" x 21.50" / 228.28 x 64.45 x 54.61 cm	1 ea
DXD490PDTWL ▲ ◆	4 Well for Acrylic and Engineered Stone Tops	61.88" x 25.38" x 21.50" / 157.61 x 64.45 x 54.61 cm	1 ea
DXD590PDTWL ▲ ◆	5 Well for Acrylic and Engineered Stone Tops	75.88" x 25.38" x 21.50" / 192.72 x 64.45 x 54.61 cm	1 ea
DXD690PDTWL ▲ ◆	6 Well for Acrylic and Engineered Stone Tops	89.88" x 25.38" x 21.50" / 228.28 x 64.45 x 54.61 cm	1 ea
180 Degree Adjustable Guard with Warmer & Lights			
DXD2180PWL ▲ ◆	2 Well	33.88" x 37.81" x 22.00" / 86.04 x 96.04 x 55.88 cm	1 ea
DXD3180PWL ▲ ◆	3 Well	47.88" x 37.81" x 22.00" / 121.60 x 96.04 x 55.88 cm	1 ea
DXD4180PWL ▲ ◆	4 Well	61.88" x 37.81" x 22.00" / 157.16 x 96.04 x 55.88 cm	1 ea
DXD5180PWL ▲ ◆	5 Well	75.88" x 37.81" x 22.00" / 192.72 x 96.04 x 55.88 cm	1 ea
DXD6180PWL ▲ ◆	6 Well	89.88" x 37.81" x 22.00" / 228.28 x 96.04 x 55.88 cm	1 ea
DXD4180PDTWL ▲ ◆	4 Well for Acrylic and Engineered Stone Tops	61.88" x 37.81" x 22.00" / 157.61 x 96.04 x 55.88 cm	1 ea
DXD5180PDTWL ▲ ◆	5 Well for Acrylic and Engineered Stone Tops	75.88" x 37.81" x 22.00" / 192.72 x 96.04 x 55.88 cm	1 ea
DXD6180PDTWL ▲ ◆	6 Well for Acrylic and Engineered Stone Tops	89.88" x 37.81" x 22.00" / 228.28 x 96.04 x 55.88 cm	1 ea

Dinex by CFS Brands NSF Listed products are designated with a ▲ and may be prefixed with an N

◆ California Residents: Bisphenol A **WARNING:** See appendix A on page 281

VALUXPRESS COUNTERS

ValuXpress

The Economical Series of Modular Counters

- Designed to meet the **increased demands** for **high quality** and **value** at a lower price point
- Extremely versatile and applicable for patient tray line or as a serving counter in the cafeteria, satellite location, and dining room
- High-quality stainless steel construction, adjustable feet and a variety of options for casters, tray slides, work shelves and protector guards
- Solid Top and Urn Counters are also available



Shown with overhead shelf



Shown with overhead shelf



Value Line Hot Food Counters

- Available in 2 or 3 well sizes, ValuXpress Hot Food Counters offer a wide variety of options and accessories
- Counters are stationary or mobile with heavy-duty 5" casters (two locking)
- Stainless steel drop-shelves are available for all configurations
- Stainless steel protector guards (sneeze guards)
- Over-shelf and Under-shelf available
- Easy Access electrical service panel
- NSF Listed



Easy Access panel; fast and easy service of all heating elements and thermostats

All options and accessories must be ordered at the same time as the counter

Prod No	Description	L x D x H	Watts	Amps	Pack
Hot Food Counters - 208 Volts / Single Phase					
DXDVLHF2 Δ	Hot Food Counter - 2 Well	35" x 30" x 36" / 88.9 x 76.2 x 91.4 cm	2000	9.6	1 ea
DXDVLHF3 Δ	Hot Food Counter - 3 Well	49" x 30" x 36" / 124.5 x 76.2 x 91.4 cm	3000	14.4	1 ea

Dinex by CFS Brands NSF Listed products are designated with a Δ and may be prefixed with an N

VALUXPRESS COUNTERS

Value Line Cold Food Counters (NSF 7)

- Available in 2 or 3 well sizes
- Cold Food Counters are the most versatile and adaptable accessory on the serving line
- Counters are stationary or mobile with optional heavy-duty 5" casters (two locking)
- Stainless drop-shelves and tray slides available for all configurations
- Undershelf standard on all models
- Units feature 9.44" deep wells (NSF 7)
- Counters ensure that food temperatures are always at safe levels
- Over-shelf & Under-shelf options available
- NSF Listed



All options and accessories must be ordered at the same time as the counter

Value Line Hot Food Counters Slim Line

- Available in 2 or 3 well sizes
- Offer a wide variety of options and accessories
- Counters are stationary or mobile with heavy-duty 5" casters (two locking)
- Stainless steel drop down work shelves are available for all configurations

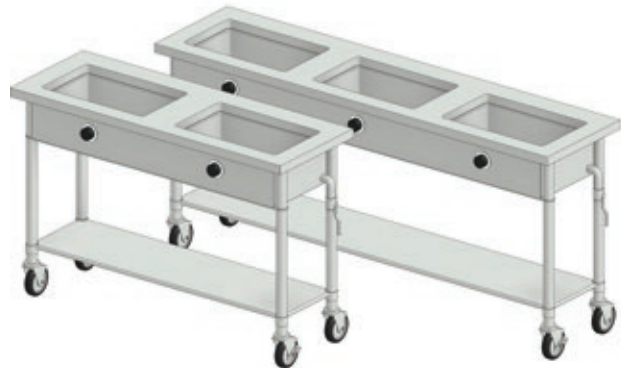

Prod No	Description	L x D x H	Watts	Amps	Pack
Slim Line Hot Food Counter - 208 Volts / Single Phase					
DXDVLHF2SL	Hot Food Counter, Slim Line - 2 Well	35" x 30" x 36" / 88.9 x 76.2 x 91.4 cm	2000	9.6	1 ea
DXDVLHF3SL	Hot Food Counter, Slim Line - 3 Well	49" x 30" x 36" / 124.5 x 76.2 x 91.4 cm	3000	14.4	1 ea
Cold Food Counters (NSF 7) - 120 Volts / Single Phase					
DXDVLCF2 ◊	Cold Food Counter - 2 Well	35" x 30" x 36" / 88.9 x 76.2 x 91.4 cm	—	7.2	1 ea
DXDVLCF3 ◊	Cold Food Counter - 3 Well	49" x 30" x 36" / 24.5 x 76.2 x 91.4 cm	—	7.2	1 ea

Dinex by CFS Brands NSF 7 Listed products are designated with a ◊



Value Line Urn Stands - Beverage Counters

- ValuXpress Urn Stands in 35" or 49" length, built to hold any configuration of fountain machines, ice makers and coffee bars
- Available with optional under-counter storage for supplies and custom "bag and box," along with tray slides

Value Line Solid Top Counters

- ValuXpress Solid Top Counters are available in 35" or 49" length
- Work shelf, tray slide, full service guard, under-shelf and overhead shelf are all available options



Prod No	Description	L x D x H	Pack
Urn Stands - Beverage Counters			
DXDVLUS2	35" Beverage Urn Stand	35" x 30" x 36" / 88.9 x 76.2 x 91.4 cm	1 ea
DXDVLUS3	49" Beverage Urn Stand	49" x 30" x 36" / 124.5 x 76.2 x 91.4 cm	1 ea
Solid Top Counters			
DXDVLST2	35" Solid Top Counter	35" x 30" x 36" / 88.9 x 76.2 x 91.4 cm	1 ea
DXDVLST3	49" Solid Top Counter	49" x 30" x 36" / 124.5 x 76.2 x 91.4 cm	1 ea
Solid Ribbed Tray Slides			
DXTSSR2	12" Solid Ribbed Tray Slide - 2 Well	—	1 ea
DXTSSR3	12" Solid Ribbed Tray Slide - 3 Well	—	1 ea
Drop Down Work Shelf			
DXDDWS2	8" Drop Down Work Shelf - 2 Well	—	1 ea
DXDDWS3	8" Drop Down Work Shelf - 3 Well	—	1 ea
Overhead Shelf			
DXOHS2	Over Head Shelf - 2 Well	—	1 ea
DXOHS3	Over Head Shelf - 3 Well	—	1 ea
Caster Upgrade Option			
DXDVLCAST	Casters, 4 Swivel, 2 w/Brake	—	1 set

DINEX®

Air Curtain Refrigerator

- FOR OPTIMAL PERFORMANCE:
- The ambient room temperature should be 60°F to 70°F.
 - Do not open the door frequently or for long periods of time.
 - Allow 15 minutes for the door to close after each opening.
 - Do not store items that are not recommended for storage in this refrigerator.
 - Do not store items that are not recommended for storage in this refrigerator.
 - Do not store items that are not recommended for storage in this refrigerator.



DINEX

OPERATIONAL INFORMATION
PLEASE FOLLOW THESE GUIDELINES

1. ALWAYS USE THE CORRECT TEMPERATURES FOR EACH TYPE OF FOOD.
2. ALWAYS USE THE CORRECT TEMPERATURES FOR EACH TYPE OF FOOD.
3. ALWAYS USE THE CORRECT TEMPERATURES FOR EACH TYPE OF FOOD.



SUPERIOR COLD TEMPERATURE SOLUTIONS **REFRIGERATION**

Dinex offers a complete solution to hold food temperatures at 41°F or less in hospital tray assembly lines, cafeterias, room service operations or anywhere you need to be temperature safe and HACCP compliant.





AIR CURTAIN REFRIGERATOR

Two Hour Hold Time and Horizontal Air Flow are the Industry's Best

Maintains proper chilled food temperatures up to two hours – even with **open** door.

Air Curtain Refrigerator

- 1 version available:
- Unit will maintain the temperature of the food at 41F or less for up to 2 hours* with the door open
- **15 slides with 3" slide spacing with non-tip feature**
- **Horizontal air screen maintains cabinet interior temperature**
- Ideal for tray assembly lines, the versatile air curtain allows the operator easy, reach-in access to prepared and portioned foods while the refrigerator door remains open
- DOE 2017 Compliant
- Available with stainless steel door, right or left hinged door that is field reversible
- Also designed for roomservice operation that requires 24/7 cold storage.



Improved performance with enhanced insulation and refrigeration system.



DXIRAC15DOERS

Combine these products with your Air Curtain.



Square Bowls
page 42



Tulip Bowls
page 41



Clear Dome
page 40



China Dishware
page 50

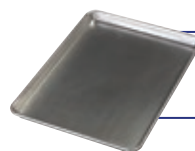

Sheet Pans
page 191

*Please read air curtain specification sheet for optimal temperature holding.



Horizontal Air Screen

Maintains an internal air temperature below 40°F



Control Panel

Easy temperature reading and programming



Sheet Pans

Carlisle Sheet Pans help complete your set-up



Durability

Bumpers protecting the unit and removable panels for an easy access to the condensing unit

Build your serving station and delight your guests with a premium service at the right food temperature

Shown:

MealtimeXpress Hot/Hot (DXMTXHH) • Plate Heater (DXIDPH2E0912)
Cateraide IT (IT40003) • Air Curtain (DXIRAC15EF)

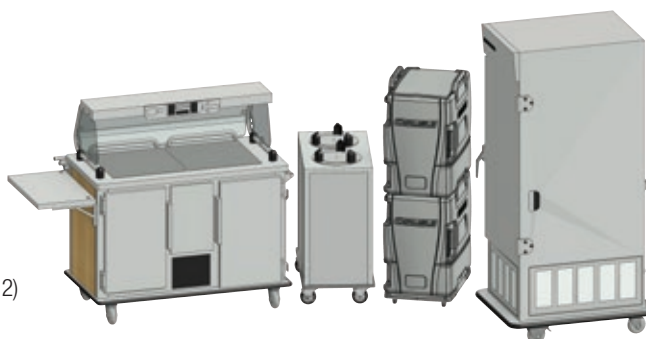

Condensing Unit Size: 1 HP

Prod No	Description	Capacity	Pack
Air Curtain Refrigerator			
DXIRAC15DOERS	Air Curtain Refrigerator, Stainless Steel Door – Right Hinged	15 Slides	1 ea
DXIRAC15DOELS	Air Curtain Refrigerator, Stainless Steel Door – Left Hinged	12 Slides	1 ea



Blast Chiller/Shock Freezer

Only Dinex offers both blast chilling and shock freezing in one unit.

- A necessary addition for meal preparation in cook-serve and cook-chill applications
- Meet **HACCP** regulations and ensure food safety
- **Improve food quality**, reduce shrinkage and increase menu flexibility
- **Blast chilling** reduces food core temperatures from 160°F to 38°F in 90 minutes
- **Blast freezing** reduces food core temperatures from 160°F to 0°F to form microcrystals and protect food texture
- Available in 5 capacities: 30 lb, 45 lb, 70 lb, 100 lb (reach in models) and 200 lb (roll-in model)

Other Features:

- Heated food probe to control the automatic mode
- Ultraviolet light to sterilize the internal metal surfaces
- Optional printer to record operating parameters



DXDBC200
Roll in rack sold separately
Holds 20 12" x 20" x 2.5" pans or 10 18" x 26" x 2.5" pans



DXDBC30
Holds 3 pans 12" x 20" x 2.5"



DXDBC45
Holds 5 pans 12" x 20" x 2.5"



DXDBC70
Holds 14 12" x 20" x 2.5" pans
or 7 18" x 26" x 2.5" pans



DXDBC110
Holds 24 12" x 20" x 2.5" pans
or 12 18" x 26" x 2.5" pans

Prod No	Description	L x D x H	Electrical/Amps	NEMA (Plug)	Capacity*	Pack
Blaster Chiller/Shock Freezer						
DXDBC30	Reach-in Blast Chiller	25.25" x 25.88" x 34" / 64.1 x 65.7 x 86.4 cm	120v, 60 Hz, 1-Phase/10	5-15P	30 lb/14 kg	1 ea
DXDBC45	Reach-in Blast Chiller	29.5" x 28.25" x 35.5" / 74.9 x 71.8 x 90.2 cm	208v, 60 Hz, 1-Phase/7	6-15P	45 lb/20 kg	1 ea
DXDBC70	Reach-in Blast Chiller	32.25" x 36" x 53" / 81.9 x 91.4 x 134.6 cm	208v, 60 Hz, 1-Phase/12	L6-20P	70 lb/32 kg	1 ea
DXDBC110	Reach-in Blast Chiller	32.25" x 36" x 74" / 81.9 x 91.4 x 188 cm	208v, 60 Hz, 3-Phase/10	L15-20P	110 lb/50 kg	1 ea
DXDBC200	Roll-in Blast Chiller	47.25" x 42" x 93" / 120 x 106.7 x 236.2 cm	208v, 60 Hz, 3-Phase/19.5	L15-30P	200 lb/90.7 kg	1 ea

*Capacities are listed if unit is used for blast chilling. If used for shock freezing capacities are as follows: DXDBC30: 18 lb/8 kg, DXDBC45: 27 lb/12 kg, DXDBC70: 42 lb/19 kg, DXDBC110: 66 lb/29 kg, DXDBC200: 200 lb/90.7 kg



DineXpress® Ice Cream Freezer

Only DineX supports your trayline with an **integrated cold side solution.**

- Freezer unit keeps ice cream and frozen desserts at the proper temperature
- Also ideal for freezing our Cool Base to ensure patient satisfaction for all of your cold foods
- Hinged top opening allows easy access to treats
- NSF Listed



Product Specifications Can Be Customized

DineXpress® Milk Cooler

Only DineX addresses the **cold milk challenge**

- Refrigerated unit keeps milk and other cold drinks at the proper temperature
- Fits standard milk crates for easy cleaning and restocking which saves labor
- Hinged top opening allows easy access
- NSF Listed



Prod No	Description	L x D x H	Pack
Ice Cream Freezer			
DXDICF	Ice Cream Freezer, 5.0 Cubic Feet	49" x 30" x 36" / 124.5 x 76.2 x 91.4 cm	1 ea
Milk Cooler			
DXDMC	Milk Cooler, 5.0 Cubic Feet	49" x 30" x 36" / 124.5 x 76.2 x 91.4 cm	1 ea

DineX by CFS Brands NSF Listed products are designated with a and may be prefixed with an N



DINEX

EFFICIENT
DURABLE
EASILY-
ADJUSTABLE
**DISPENSERS &
HEATERS**

Featuring a small footprint and ergonomic design Dinx dispensers & heaters save space in your kitchen and increase productivity on your assembly line.



BASE & PLATE HEATERS

Dinex has unique features to get your trayline off to a great start. Flavorful **hot food** and a **great patient experience** start with a hot plate. Dinex has a variety of ways to heat plates to the **proper temperature** so the food stays hot and fresh.

All Convection Plate & Base Heaters Share These Common Features:

- Convection heating ensures even temperatures
- Stainless steel exterior and corner bumpers for durability
- Convection plate heaters are perfect for back-of-house applications and assembly lines
- Available in 2 and 3 silo configurations—each with heavy duty casters
- NSF Listed



DXIDPC20120



HACCP Compliant – elevator is removable for easy access to the silo for cleaning.



Easy-to-use controller adjusts temperatures from 140°F to 330°F (60°C to 166°C).



Only Dinex offers a latchless hinged lid and safety open lid catch to prevent accidental lid closures.

Colossus Convection Plate Heater

- Colossus Heated Plate Dispenser is designed for heating china plates (from 7" to 10.25" in diameter) to a temperature of 170°F in less than two hours
- Unique Spring-Pak, self-leveling mechanism that lasts longer than the competition and is easier to adjust
- Holds up to 150 plates in the 2 silo and up to 225 plates in the 3 silo



Dinex China Plates
page 50

Prod No	Description	L x D x H	Watts/Amps	Capacity	Pack
Colossus Convection Plate Heater - 208v 60Hz					
DXIDPC20120 ▲	Plate Heater - 2 Silo for 10.25" Plates	35.36" x 23.68" x 42.96" / 89.8 x 60.1 x 109.2 cm	3200/15.4	150 Plates	1 ea
DXIDPC30180 ▲	Plate Heater - 3 Silo for 10.25" Plates	45" x 23.75" x 42.96" / 114.3 x 60.3 x 109.2 cm	4800/23.1	225 Plates	1 ea

Dinex by CFS Brands NSF Listed products are designated with a ▲ and may be prefixed with an N

Note: Capacities may vary due to plate thickness.

Spring and temperature adjustments not covered under warranty.

Personal protection equipment should be worn when handling hot plates and bases from unit.



DXIDWB20900

Convection Wax Base Heater

- Two silo unit holds up to 120 bases; three silo unit holds up to 180 bases
- Use with Wax Bases shown on page 37
- NSF Listed



Wax Base & Wax Base Underliner
page 37

Visit the Dinex Video Library for Information
www.carlislefsp.com/videos.

Combination Convection Wax Base & Plate Heater

- The versatile Combination Base and Plate Heater is constructed of heavy gauge stainless steel, and is sized for optimal space conservation
- Designed for heating wax bases up to 330°F and plates to 170°F in less than two hours
- Heater holds up to 60 wax bases and 75 9" china plates
- Use with Wax Bases shown on page 37
- NSF Listed



DXIDPWB20900

Prod No	Description	L x D x H	Volts/Watts/ Amps	Capacity	Pack
Convection Wax Base Heater - 208v 60Hz					
DXIDWB20900 Δ	9" Wax Base Dispenser - 2 Silo	35.36" x 23.68" x 42.96" / 89.8 x 60.1 x 109.2 cm	208/3200/15.4	120 Bases	1 ea
DXIDWB30900 Δ	9" Wax Base Dispenser - 3 Silo	45" x 23.68" x 42.96" / 114.3 x 60.1 x 109.2 cm	208/4800/23.1	180 Bases	1 ea
Combination Wax Base & Plate Heater - Elec @ 280v 1-Phase					
DXIDPWB20900 Δ	Combo Base & Plate Heater for 9" Plates	35.36" x 23.68" x 42.96" / 89.8 x 60.1 x 109.2 cm	208/3200/15.4	60 Bases 75 Plates	1 ea

Dinex by CFS Brands NSF Listed products are designated with a Δ and may be prefixed with an N

Note: Capacities may vary due to plate thickness.

Spring and temperature adjustments not covered under warranty.

Personal protection equipment should be worn when handling hot plates and bases from unit.



PLATE DISPENSERS & WARMERS

Enclosed Silo Plate Dispensers

Dinex Plate Dispensers are **durable** and **easy to adjust** with their **self-leveling mechanism**. Perfect solution for any front-of-house application.

- Enclosed Plate Dispensers are offered in 2, 3, and 4 silo configurations
- Designed for front-of-house applications
- Each has a stainless steel exterior shield and is equipped with 4" heavy duty non-marking swivel casters
- **Feature the Dinex Spring-Pak self-leveling mechanism**
- Plate dispensers come in both heated and unheated styles
- 2 silo units hold approximately 100 plates; 3 silo units 150 plates, and 4 silo units 200 plates
- Some units are NSF Listed, see product chart for details



DXIDP2E0912



Plate warmers are not recommended for back-of-house and patient tray assembly operation. See page 128 for Colossus plate heater for back-of-house application.

Prod No	Description	L x D x H	Pack	
Unheated Enclosed Style Plate Dispensers 2 Silo - 100 Plates / 72 Bowls (Approx)				
DXIDP2E0912 Δ	Enclosed Style - 2 Silo, 9.13" Plate	32" x 18.5" x 36.75" / 81 x 47 x 93 cm	1 ea	
DXIDP2E1012 Δ	Enclosed Style - 2 Silo, 10.13" Plate	32" x 18.5" x 36.75" / 81 x 47 x 93 cm	1 ea	
DXIDP2E1200 Δ	Enclosed Style - 2 Silo, 12" Plate	36.5" x 20.75" x 36.75" / 93 x 53 x 93 cm	1 ea	
Unheated Enclosed Style Plate Dispensers 3 Silo - 150 Plates / 108 Bowls (Approx)				
DXIDP3E0912	Enclosed Style - 3 Silo, 9.13" Plate	46.5" x 18.5" x 36.75" / 118 x 47 x 93 cm	1 ea	
DXIDP3E1012	Enclosed Style - 3 Silo, 10.13" Plate	46.5" x 18.5" x 36.75" / 118 x 47 x 93 cm	1 ea	
DXIDP3E1200	Enclosed Style - 3 Silo, 12" Plate	53.25" x 20.75" x 36.75" / 135.2 x 52.7 x 93 cm	1 ea	
Prod No	Description	L x D x H	Volts/Watts/Amps	Pack
Heated Enclosed Style Plate Dispensers 2 Silo - 100 Plates / 72 Bowls (Approx)				
DXIDPH2E0912 Δ	Enclosed Style - 2 Silo, 9.13" Plate	32" x 18.5" x 36.75" / 81 x 47 x 93 cm	120/1000/8.4	1 ea
DXIDPH2E1012 Δ	Enclosed Style - 2 Silo, 10.13" Plate	32" x 18.5" x 36.75" / 81 x 47 x 93 cm	120/1000/8.4	1 ea
DXIDPH2E1200 Δ	Enclosed Style - 2 Silo, 12.25" Plate	36.5" x 20.75" x 36.75" / 92.7 x 52.7 x 93 cm	120/1000/8.4	1 ea
Heated Enclosed Style Plate Dispensers 3 Silo - 150 Plates / 108 Bowls (Approx)				
DXIDPH3E0912 Δ	Enclosed Style - 3 Silo, 9.13" Plate	46.5" x 18.5" x 36.75" / 118 x 47 x 93 cm	120/1500/12.5	1 ea
DXIDPH3E1012 Δ	Enclosed Style - 3 Silo, 10.13" Plate	46.5" x 18.5" x 36.75" / 118 x 47 x 93 cm	120/1500/12.5	1 ea
DXIDPH3E1200	Enclosed Style - 3 Silo, 12.25" Plate	53.25" x 20.75" x 36.75" / 135.2 x 52.7 x 93 cm	120/1500/12.5	1 ea
Heated Enclosed Style Plate Dispensers 4 Silo - 200 Plates / 144 Bowls (Approx)				
DXIDPH4E0912 Δ	Enclosed Style - 4 Silo, 9.13" Plate	32" x 32" x 36.75" / 81 x 81 x 93 cm	120/2000/16.8	1 ea
DXIDPH4E1012 Δ	Enclosed Style - 4 Silo, 10.13" Plate	32" x 32" x 36.75" / 81 x 81 x 93 cm	120/2000/16.8	1 ea
DXIDPH4E1200	Enclosed - 4 Silo, 12" Plate	39" x 36.5" x 36.75" / 99.1 x 93 x 93 cm	120/2000/16.8	1 ea

Dinex by CFS Brands NSF Listed products are designated with a Δ and may be prefixed with an N

Note: Capacities may vary due to plate thickness. Contact factory for plate sizes not listed.

Spring and temperature adjustments not covered under warranty. No guarantee of temperature for unheated or heated models.

Silo covers recommended for best results.

Silo covers sold separately.

Open Silo Plate Dispensers & Warmers

- Designed for front-of-the-house applications
- Open Plate Dispensers are offered in 2 or 3 silo configurations
- Each has a stainless steel exterior shield and is equipped with 4" heavy duty non-marking swivel casters
- Feature the Dinex Spring-Pak self-leveling mechanism
- Plate dispensers come in both heated and unheated styles
- 2 silo units hold approximately 100 plates and 3 silo units 150 plates
- Some units are NSF Listed, see product chart for details

Plate warmers are not recommended for back-of-house and patient tray assembly operation. See page 128 for Colossus plate heater for back-of-house application.



DXIDP200912



Prod No	Description	L x D x H	Pack
Unheated Open Style Plate Dispensers 2 Silo - 100 Plates / 72 Bowls (Approx)			
DXIDP200912 Δ	Open Style - 2 Silo, 9.13" Plate	35.5" x 17.75" x 39" / 90.2 x 45.1 x 99 cm	1 ea
DXIDP201012 Δ	Open Style - 2 Silo, 10.13" Plate	35.5" x 17.75" x 39" / 90.2 x 45.1 x 99 cm	1 ea
DXIDP201200 Δ	Open Style - 2 Silo, 12" Plate	35.5" x 17.75" x 39" / 90.2 x 45.1 x 99 cm	1 ea
Unheated Open Style Plate Dispensers 3 Silo - 150 Plates / 108 Bowls (Approx)			
DXIDP300912 Δ	Open Style - 3 Silo, 9.13" Plate	45.75" x 17.75" x 39" / 116.2 x 45.1 x 99 cm	1 ea
DXIDP301012 Δ	Open Style - 3 Silo, 10.13" Plate	45.75" x 17.75" x 39" / 116.2 x 45.1 x 99 cm	1 ea
DXIDP301200	Open Style - 3 Silo, 12" Plate	52.5" x 17.75" x 39" / 133.4 x 45.1 x 99 cm	1 ea

Prod No	Description	L x D x H	Volts/Watts/Amps	Pack
Heated Open Style Plate Dispensers 2 Silo - 100 Plates / 72 Bowls (Approx)				
DXIDPH200912 Δ	Open Style - 2 Silo, 9.13" Plate	35.5" x 17.75" x 39" / 90.2 x 45.1 x 99 cm	120/1000/8.4	1 ea
DXIDPH201012 Δ	Open Style - 2 Silo, 10.13" Plate	35.5" x 17.75" x 39" / 90.2 x 45.1 x 99 cm	120/1000/8.4	1 ea
DXIDPH201200 Δ	Open Style - 2 Silo, 12" Plate	35.5" x 17.75" x 39" / 90.2 x 45.1 x 99 cm	120/1000/8.4	1 ea

Dinex by CFS Brands NSF Listed products are designated with a Δ and may be prefixed with an N
 Note: Capacities may vary due to plate thickness. Contact factory for plate sizes not listed.



PLATE & TRAY DISPENSERS

Drop-In Plate Dispensers

Choose DineX drop-in dispensers for their **versatility**, **durability** and ease of use.

- Drop-in plate dispensers are available to accommodate the full range of plate sizes used in today's foodservice industry
- Constructed from easy-to-clean stainless steel and feature the DineX self-leveling mechanism
- Drop-in plate dispensers come in both heated and unheated styles with a capacity of up to 50 plates
- Drop-in plate dispensers can be used with open silo plate dispensers or included in the design of a DineXpress front-of-house serving counter
- Also feature Spring-Pak, the industry's only self-leveling mechanism that lasts longer than the competition and is easier to adjust



DXIACPHC0912



DXIDPDS0912



DXIDPHD0912

Prod No	Description	Cut Out Flange Dia	Max Dia	Plate	Pack
28" Unheated Drop-In Plate Dispensers - 50 Plates / 36 Bowls (Approx)					
DXIDPDS0912	28" Drop-In, Shielded	12.38"	11.56"	9.13"	1 ea
DXIDPDS1012	28" Drop-In, Shielded	13.38"	12.56"	10.13"	1 ea
DXIDPDS1200	28" Drop-In, Shielded	15.88"	14.69"	12.25"	1 ea

Prod No	Description	Cut Out Flange Dia	Max Dia	Plate	Watts	Amps	Pack
28" Heated Drop-In Plate Dispensers - 50 Plates / 36 Bowls (Approx)							
DXIDPHD0912	28" Drop-In, Shielded	12.38"	11.56"	9.13"	500	4.2	1 ea
DXIDPHD1012	28" Drop-In, Shielded	13.38"	12.56"	10.13"	500	4.2	1 ea
DXIDPHD1200	28" Drop-In, Shielded	15.88"	14.69"	12.25"	500	4.2	1 ea

Prod No	Description	Height*	Diameter	Pack
Plate Dispenser Accessories				
DXIACPHC0912	Plate Heater Silo Cover 9.13"	5.44"	9.69"	1 ea
DXIACPHC1012	Plate Heater Silo Cover 10.13"	5.44"	10.75"	1 ea
DXIACPHC1200	Plate Heater Silo Cover 12"	5.44"	12.66"	1 ea
DXIADWB	Wrap-around bumper (Not available for open style dispensers)	—	—	1 ea

Contact factory for plate sizes not listed

*Overall height with knob 6.3"



DXIDT1C1520

Dinex Tray Dispensers

Tray dispensers also feature Spring-Pak, the **industry's only self-leveling mechanism** that lasts longer than the competition and is easier to adjust.

- Tray dispensers are offered in a variety of styles—with several units available in a single or double configuration
- All feature the Dinex Spring-Pak self-leveling mechanism and are equipped with locking swivel casters
- Self leveling dispensers increase productivity during meal production
- Tray dispensers can be adjusted to accommodate different tray types
- Some units are NSF Listed, see product chart for details

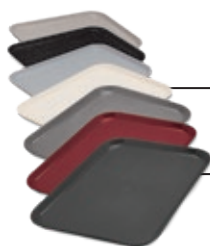

Trays
page 43



DXIDT1C1520

Safety bar can easily be removed and is designed to hang on back of dispenser when not in use.

Cantilever Single Stack Tray Dispensers

- Cantilever style models offer a removable safety bar that can be stored on back of the dispenser when not in use
- Dispensers have four 5" heavy-duty non-marking swivel casters (2 with brakes)
- Compact size saves space in the kitchen

Prod No	Description	Max Tray Size	L x D x H	Pack
Cantilever Tray Dispensers - 100 Capacity				
DXIDT1C1222 Δ	Cantilever, Single Stack	12" x 22" / 30.5 x 55.9 cm	22.75" x 29.75" x 37.75" / 57.8 x 75.6 x 95.9 cm	1 ea
DXIDT1C1321	Cantilever, Single Stack	13" x 21" / 33 x 53.3 cm	22.75" x 29.75" x 37.75" / 57.8 x 75.6 x 95.9 cm	1 ea
DXIDT1C1418 Δ	Cantilever, Single Stack	14" x 18" / 35.6 x 45.7 cm	22.75" x 29.75" x 37.75" / 57.8 x 75.6 x 95.9 cm	1 ea
DXIDT1C1520 Δ	Cantilever, Single Stack	15" x 20" / 38.1 x 50.8 cm	22.75" x 29.75" x 37.75" / 57.8 x 75.6 x 95.9 cm	1 ea
DXIDT1C1622 Δ	Cantilever, Single Stack	16" x 22" / 40.6 x 55.9 cm	22.75" x 30.88" x 37.75" / 57.8 x 78.4 x 95.9 cm	1 ea
DXMOCTD Δ	Cantilever Tray Dispenser for Meals On Command	13.5" x 23" / 34.3 x 58.4 cm	22.75" x 30.88" x 37.75" / 57.8 x 78.4 x 95.9 cm	1 ea

Dinex by CFS Brands NSF Listed products are designated with a Δ and may be prefixed with an N



TRAY DISPENSERS

Enclosed Tray Dispensers

- Choose enclosed tray dispensers for a clean, uncluttered look in your kitchen or cafeteria
- They are made of all-welded stainless steel construction and accept trays on a stainless steel spring-loaded, self-leveling carriage
- Dispensers have four 5" heavy-duty non-marking swivel casters (2 with brakes)
- NSF Listed



DXIDT1E1520



DXIDT1S1520

Tray Dispensers - Solid Shelf

- Versatile front-of-house or back-of-house application
- Self-leveling mobile tray dispensers have a high-strength tubular frame with solid bottom and fully welded safety bar
- Dispensers offer four 5" heavy-duty non-marking swivel casters (2 with brakes) and a non-marking corner bumper
- NSF Listed



Prod No	Description	Max Tray Size	L x D x H	Pack
Enclosed Single Stack Tray Dispensers - 150 Capacity				
DXIDT1E1418 Δ	Enclosed, Single Stack	14" x 18" / 35.6 x 45.7 cm	23.5" x 19.63" x 36.38" / 59.7 x 49.9 x 92.4 cm	1 ea
DXIDT1E1520 Δ	Enclosed, Single Stack	15" x 20" / 38.1 x 50.8 cm	23.5" x 19.63" x 36.38" / 59.7 x 49.9 x 92.4 cm	1 ea
DXIDT1E1622 Δ	Enclosed, Single Stack	16" x 22" / 40.6 x 55.9 cm	26" x 21.13" x 36.68" / 69.7 x 57.7 x 91.4 cm	1 ea
Enclosed Double Stack Tray Dispensers - 300 Capacity				
DXIDT2E1418 Δ	Enclosed, Double Stack	14" x 18" / 35.6 x 45.7 cm	23.5" x 40" x 36.38" / 59.7 x 101.6 x 92.4 cm	1 ea
DXIDT2E1520 Δ	Enclosed, Double Stack	15" x 20" / 38.1 x 50.8 cm	23.5" x 40" x 36.38" / 59.7 x 101.6 x 92.4 cm	1 ea
DXIDT2E1622 Δ	Enclosed, Double Stack	16" x 22" / 40.6 x 55.9 cm	26" x 43" x 36.38" / 69.7 x 109.2 x 92.4 cm	1 ea
Open Single Stack Tray Dispensers - 150 Capacity				
DXIDT1S1418 Δ	Open Single, Solid Shelf	14.75" x 18.75" / 37.5 x 47.6 cm	22.45" x 22.7" x 36" / 69.7 x 57.7 x 91.4 cm	1 ea
DXIDT1S1520 Δ	Open Single, Solid Shelf	15.75" x 20.75" / 40 x 52.7 cm	22.45" x 22.7" x 36" / 69.7 x 57.7 x 91.4 cm	1 ea
DXIDT1S1622 Δ	Open Single, Solid Shelf	16.75" x 22.38" / 42.5 x 56.8 cm	22.45" x 22.7" x 36" / 69.7 x 57.7 x 91.4 cm	1 ea
Open Double Stack Tray Dispensers - 300 Capacity				
DXIDT2S1418 Δ	Open Double, Solid Shelf	14.75" x 18.75" / 37.5 x 47.6 cm	22.7" x 22.7" x 36" / 57.7 x 57.7 x 91.4 cm	1 ea
DXIDT2S1520 Δ	Open Double, Solid Shelf	15.75" x 20.75" / 40 x 52.7 cm	22.7" x 22.7" x 36" / 57.7 x 57.7 x 91.4 cm	1 ea
DXIDT2S1622 Δ	Open Double, Solid Shelf	16.75" x 22.38" / 42.5 x 56.8 cm	22.7" x 22.7" x 36" / 57.7 x 57.7 x 91.4 cm	1 ea

Dinex by CFS Brands NSF Listed products are designated with a Δ and may be prefixed with an N



Tray & Silverware Dispensers

- **Save space in the kitchen**
- Combination tray and silverware dispensers are offered in a single stack model with six or eight silverware holders, or double stack with eight or ten silverware holders
- Each style can accommodate several different tray types
- Cantilever style available in single stack configuration with eight or ten silverware holders
- Solid shelf style available in both single and double stack configurations with six, eight, or ten silverware holders
- NSF Listed



Prod No	Description	Max Tray Size	L x D x H	Pack
Single Stack Cantilever Style Tray & Silverware Dispensers - 9 Cylinder - 150 Tray Capacity				
DXIDTS1C1321 ▲	Cantilever Style	13" x 21" / 33 x 53.3 cm	22.75" x 29.5" x 55" / 57.8 x 74.9 x 139.7 cm	1 ea
DXIDTS1C1418 ▲	Cantilever Style	14" x 18" / 35.6 x 45.7 cm	22.75" x 29.5" x 55" / 57.8 x 74.9 x 139.7 cm	1 ea
DXIDTS1C1520 ▲	Cantilever Style	15" x 20" / 38.1 x 50.8 cm	22.75" x 29.5" x 55" / 57.8 x 74.9 x 139.7 cm	1 ea
DXIDTS1C1622 ▲	Cantilever Style	16" x 22" / 40.6 x 55.9 cm	22.75" x 30.88" x 55" / 57.8 x 78.4 x 139.7 cm	1 ea
Single Stack Shelf Style Tray & Silverware Dispensers - 8 Cylinder - 150 Tray Capacity				
DXIDTS1S1418 ▲	Shelf Style	14.75" x 18.75" / 37.5 x 47.6 cm	22.75" x 28.75" x 53.25" / 57.8 x 73 x 135.3 cm	1 ea
DXIDTS1S1520 ▲	Shelf Style	15.75" x 20.75" / 40 x 52.7 cm	22.75" x 28.75" x 53.25" / 57.8 x 73 x 135.3 cm	1 ea
DXIDTS1S1622 ▲	Shelf Style	16.75" x 22.38" / 42.5 x 56.8 cm	22.75" x 28.75" x 53.25" / 57.8 x 73 x 135.3 cm	1 ea
Double Stack Shelf Style Tray & Silverware Dispensers - 16 Cylinder - 300 Tray Capacity				
DXIDTS2S1418 ▲	Shelf Style	14.75" x 18.75" / 37.5 x 47.6 cm	44.75" x 28.75" x 53.25" / 113.7 x 73 x 135.3 cm	1 ea
DXIDTS2S1520 ▲	Shelf Style	15.75" x 20.75" / 40 x 52.7 cm	44.75" x 28.75" x 53.25" / 113.7 x 73 x 135.3 cm	1 ea
DXIDTS2S1622 ▲	Shelf Style	16.75" x 22.38" / 42.5 x 56.8 cm	44.75" x 28.75" x 53.25" / 113.7 x 73 x 135.3 cm	1 ea

Dinex by CFS Brands NSF Listed products are designated with a ▲ and may be prefixed with an N

We do not accept returns on any Dinex® equipment or Dinex® custom products.
Please contact your local Dinex® representative to ensure order accuracy prior to ordering.



RACKS

Drying & Storage Racks

- Versatile mobile racks for domes and bases **accommodate every foodservice need**
- Drying and Storage Racks keep your trayline and dishwashing area organized and operating at peak efficiency
- The stainless steel cradles are removable for easy cleaning in the dishwasher
- Induction Base Drying Racks are designed to efficiently dry, store and transport your Induction Bases
- DX1173XC10 Drying Cradle Insert is an easy carry cradle, made entirely of stainless steel; holds domes and bases securely for easier washing, drying and storage
- Some units are NSF Listed, see product chart for details
- Locking casters allow for safe and easy staging of your trayline
- The tray drying rack allows for ample ventilation for drying and storage of trays



DX1173X50



DX1173X100



DXIBDRS90



DX10053



DX1173XC10



DXIDTDR3

Prod No	Description	L x D x H	Pack
Stainless Steel Storage Racks For 9" Domes & Underliners			
DX1173X50 ▲	Holds 50 domes or 100 bases/underliners	19.5" x 20.25" x 73" / 49.5 x 51.4 x 185.4 cm	1 ea
DX1173X80 ▲	Holds 80 domes or 160 bases/underliners	40" x 20.25" x 59" / 101.5 x 51.4 x 149.8 cm	1 ea
DX1173X100 ▲	Holds 100 domes or 200 bases/underliners	40" x 20.25" x 73" / 101.5 x 51.4 x 185.4 cm	1 ea
DX1173XC10	Replacement Drying Cradle Insert for DX1173 Series	18" x 17.5" x 10.5" / 45.7 x 44.4 x 26.7 cm	1 ea
Storage Racks For Induction Bases			
DXIBDRS90 ▲	Holds 90 Induction Bases	20.5" x 22" x 78" / 52.1 x 55.9 x 198.1 cm	1 ea
DXIBDRS180 ▲	Holds 180 Induction Bases	40" x 22" x 78" / 101.6 x 55.9 x 198.1 cm	1 ea
DXIBDRS270 ▲	Holds 270 Induction Bases	59.5" x 22" x 78" / 151.1 x 55.9 x 198.1 cm	1 ea
DX10251DT	Replacement Wire Cradle (18 bases per cradle)	17.75" x 18" x 6" / 45.1 x 45.7 x 15.2 cm	1 ea
Stainless Steel Storage Racks For 9" Domes & Underliners			
DXIRDSD950 ▲	Holds 50 domes or 100 bases/underliners	22.5" x 22" x 78" / 57.1 x 55.8 x 198.1 cm	1 ea
DXIRDSD9100 ▲	Holds 100 domes or 200 bases/underliners	44" x 22" x 78" / 111.7 x 55.8 x 198.1 cm	1 ea
DXIRDSD9150 ▲	Holds 150 domes or 300 bases/underliners	65.5" x 22" x 78" / 166.2 x 55.8 x 198.1 cm	1 ea
DX10053	Washrack & Cradle for 9" Domes (fits D950, D9100, D9150)	19" x 18.25" x 7.5" / 48.7 x 46.36 x 19 cm	2 ea
Flat Tray Drying Racks			
DXIDTDR3	Drying rack for 14"x 18" & 15"x 20" flat trays (approx 120 trays)	63.75" x 28" x 74.5" / 161.8 x 71.1 x 189.2cm	1 ea

Dinex by CFS Brands NSF Listed products are designated with a ▲ and may be prefixed with an N

WASHRACK DISPENSERS

Washrack Dispensers For Trayline & Meal Delivery Systems

- **Choose Dinex** for long lasting and **dependable service**
- All washracks feature stainless steel construction including durable stainless steel extension springs
- Dinex self-leveling mobile washrack dispenser is available in several styles including cantilever, enclosed and drop-in
- Mobile washrack dispensers can be used in front or back-of-house settings including traylines or beverage service areas
- Self-leveling mechanism lifts out for easy cleaning
- Field adjustable to accommodate different weights
- Mobile units feature corner bumpers
- Cantilever & Enclosed style dispensers are NSF Listed



DXIDRE2020 Enclosed Style Rack Dispenser



DXIDRC2020 Cantilever Style Rack Dispenser



DXIDRS2020 Shelf Style Rack Dispenser



DXIDRD2020 Drop In Style Rack Dispenser



OptiClean Washracks
page 214

Prod No	Description	Rack Size	L x D x H	Pack
Cantilever Style Mobile Rack Dispenser				
DXIDRC1020 Δ	Mobile Rack Dispenser	10" x 20"	23.5" x 23.25" x 37.13" / 59.7 x 59.1 x 94.3 cm	1 ea
DXIDRC2020 Δ	Mobile Rack Dispenser	20" x 20"	23.5" x 31.25" x 37.13" / 59.7 x 79.4 x 94.3 cm	1 ea
Enclosed Style Mobile Rack Dispenser				
DXIDRE1020 Δ	Mobile Rack Dispenser	10" x 20"	25.69" x 23.75" x 36.13" / 65.3 x 60.3 x 91.8 cm	1 ea
DXIDRE2020 Δ	Mobile Rack Dispenser	20" x 20"	25.69" x 23.75" x 36.13" / 65.3 x 60.3 x 91.8 cm	1 ea
Shelf Style Mobile Rack Dispenser				
DXIDRS1020	Mobile Rack Dispenser	10" x 20"	18.16" x 23.63" x 36.25" / 46.1 x 60 x 92.1 cm	1 ea
DXIDRS2020	Mobile Rack Dispenser	20" x 20"	27.16" x 28.35" x 37.15" / 69 x 72 x 91.8 cm	1 ea
Drop In Style Mobile Rack Dispenser				
DXIDRD1020	Mobile Rack Dispenser	10" x 20"	23.25" x 25.19" x 28.25" / 59.1 x 63.9 x 71.8 cm	1 ea
DXIDRD2020	Mobile Rack Dispenser	20" x 20"	23.25" x 25.19" x 28.25" / 59.1 x 63.9 x 71.8 cm	1 ea

Dinex by CFS Brands NSF Listed products are designated with a Δ and may be prefixed with an N
Note: Capacity may vary due to material thickness.



DINEX

INNOVATIVE QUIET RELIABLE **TRAY DELIVERY CARTS**

Delivering a hotel style atmosphere and supporting "H.U.S.H" initiatives without compromising style, durability and versatility. Dinex high quality meal delivery carts feature a heavy-duty design and come in a variety of configurations.



MEAL DELIVERY CART SOLUTIONS

More choices than any other company.

Only Dinex has a solution to fit all your needs when it comes to meal delivery carts. From TQ Supreme carts that enhance hospitality with its upscale aesthetic to our budget conscious TQ Economy collection, Dinex has **an option for every situation.**

Front of the House Hospitality



TQ Supreme

Bring more hospitality to your facility with a quiet cart that coordinates with your hospital decor and can be aesthetically customized to broadcast your brand

Quiet Heavy Duty



TQ Cart

The original quiet and heavy duty tray delivery cart

Light and Compact



TQ Economy

Light and compact meal delivery cart for facilities having limited storage space

Value Line Cart in Durable Stainless Steel



TVL

Economic stainless steel cart for meal delivery or tray retrieval

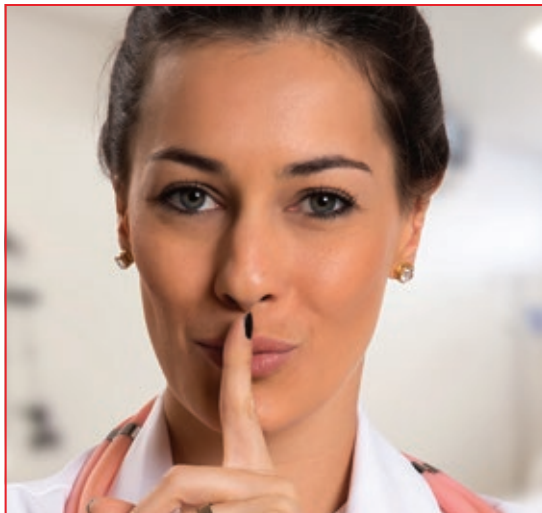

Loaded Food Cart Noise Levels

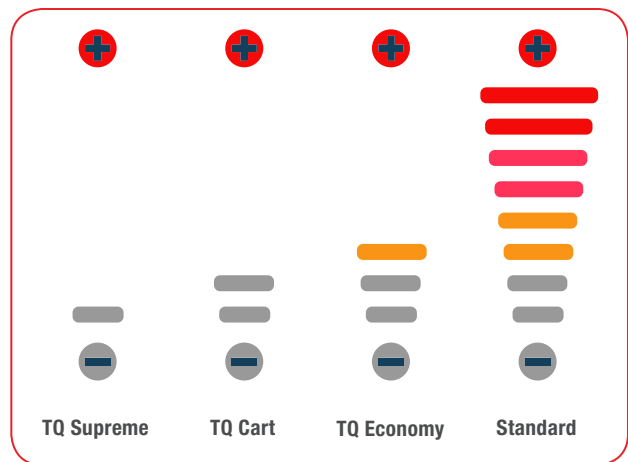

Combine these products with your meal delivery cart.



Cascata Carafe
page 168



Service Mats
page 171



Coldmaster
page 208



Trays & Traytop
page 26



TQ Supreme



TQ Cart



TQ Economy



TVL

Key Features

Quiet, Front-of-house customer experience, aesthetically customizable

Quiet, heavy duty welded stainless steel

Light, small foot print, Quiet

Stainless steel for the price of plastic

Noise Dampening

Noise Perception

Totally Quiet Supreme

Totally Quiet

Quiet Cart

Traditional Cart

Maneuverability

Push/Pull Effort

4 lbs

5 lbs

4 lbs

4 lbs

Handle Configuration

Vertical & Horizontal Push Handles

Vertical Push Handle

Optional Push Handle

No Push Handle

Dimensions

31.04" x 35.95" x 43.50"

31.64" x 36.21" x 39.79"

23.75" x 34.22" x 37.12"

27.72" x 38.12" x 34.83"

(1 door, 2 trays – 10 tray capacity)

Height Includes Top Rail

40.67" to Top Flat Surface

Durability

Frame Material

Stainless Steel & Aluminum

Stainless Steel

Stainless Steel

Stainless Steel

Panels

Replaceable

Fixed

Fixed

Fixed

Wrap Around Bumper

Standard

Optional

Optional

Standard

Door Catch

Magnetic Catch

Gravity Lock

Magnetic Catch

Drop Down Latch

Warranty

1 Year

1 Year

1 Year

1 Year

NSF Listed

Yes

Yes

Yes

Yes

(Carlisle FoodService Products)

Cleanability

Drain

Standard

Optional

Optional

Standard

Tray Rack

Stainless Steel, Adjustable & Removable

Stainless Steel, Adjustable & Removable

Stainless Steel, Fixed

Stainless Steel
Adjustable Tray Slides

Ergonomics

3-Sided Top Rail

Standard (Top is Secured for Accessories)

Optional

Optional

Optional

Brake

On Swivel Casters

On Swivel Casters

On Swivel Casters

On Swivel Casters

Casters

6"

6"

5"

5"

Tray Sizes

14" x 18", 15" x 20", 12" x 19" or 12" x 20"

12" x 19", 12" x 20", 12" x 22", 13" x 21", 14" x 18", 15" x 20" or 16" x 22"

14" x 18", 15" x 20", 12" x 19" or 12" x 20"

14" x 18", 15" x 20", 12" x 19" or 12" x 20"

Design & Aesthetics

Styling

Modern - Rounded

Traditional - Square

Traditional - Square

Traditional - Square

Customizable Aesthetic

Yes

No

No

No

Customizable Dimension

No

Yes

Yes

No



TQ SUPREME

Bring a hotel atmosphere and **enhance hospitality** with TQ Supreme; the **first tray delivery cart that is totally quiet, front-of-house looking and aesthetically customizable.**



Shown with Cherry Signature Woodgrain Option

TQ SUPREME - Bring a Hotel Atmosphere and Enhance Hospitality

- Available in 1 tray 1 door version for 6 and 8 tray capacity as well as 2 trays 1 door version for 10, 12, 16, 20 tray capacity
- 10, 12, 16 tray capacity carts are also available in a pass thru version
- Replaceable stainless steel panels come standard; signature woodgrain panels are optional
- 4-sided top rail, full perimeter bumper, floor drain come standard
- Magnetic door lock to hold the door closed and open at 270°
- Contact your local Dinex sales representative for more details

Watch our video on the TQ Supreme at www.carlislefsp.com/videos.

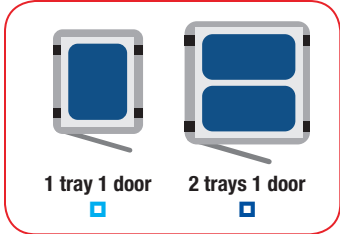

Features



Quiet
Sound dampening design includes a magnetic door lock, Quiet Casters and many other noise-canceling features



Easy to Maneuver
Vertical and horizontal push handle



User Safety
Recessed vertical push handle for hand protection



Robust
Heavy-duty, stainless steel base construction surrounded by a full perimeter bumper



Easy To Clean
Removable tray rack for easy cleaning



Smart Design
Floor drain, full perimeter bumper and four-sided top rail come standard

Options & Accessories



Pass-thru option available in 10- and 12-tray capacity carts



Cold beverage & condiment carrier (see Coldmaster CoolCheck & Accessories chart on page 143 for a list of support products for carts)



Custom Panels

Build your Brand

Use TQ Supreme's customizable panels to promote your brand. Our colorful, animal or aquarium themes create a fun atmosphere for pediatric environments.



Design your own cart with Dinex web builder at www.carlislefsp.com/tq-cart-wizard. The customization options are endless.



Personalize the Cart with Your Logo and Graphics



Prod No	Description	L x D x H	Pack
TQ Supreme – With Standard Stainless Steel Panels			
DXSU1T1D6 ▲ ■	TQ Supreme – 1 Tray 1 Door - 6	26" x 25.54" x 48.42"	1 ea
DXSU1T1D8 ▲ ■	TQ Supreme – 1 Tray 1 Door - 8	26" x 25.54" x 58.92"	1 ea
DXSU2T1D10 ▲ ■	TQ Supreme – 2 Trays 1 Door - 10	31.04" x 35.95" x 43.40"	1 ea
DXSU2T1D12 ▲ ■	TQ Supreme – 2 Trays 1 Door - 12	31.04" x 35.95" x 48.65"	1 ea
DXSU2T1D16 ▲ ■	TQ Supreme – 2 Trays 1 Door - 16	31.04" x 35.95" x 58.96"	1 ea
DXSU2T1D20 ▲ ■	TQ Supreme – 2 Trays 1 Door – 20	31.04" x 35.95" x 64.46"	1 ea
DXSU2T1DPT10 ▲ ■	TQ Supreme – 2 Trays 1 Door - 10 - Pass Through	31.04" x 35.95" x 43.40"	1 ea
DXSU2T1DPT12 ▲ ■	TQ Supreme – 2 Trays 1 Door - 12 - Pass Through	31.04" x 35.95" x 48.65"	1 ea
DXSU2T1DPT16 ▲ ■	TQ Supreme – 2 Trays 1 Door - 16 - Pass Through		
Signature Panel Options			
DXSUSMA†	Maple Signature Panels - Single Door, Two Trays per Slide	—	1 ea
DXSUSCH†	Cherry Signature Panels - Single Door, Two Trays per Slide	—	1 ea
DXSUSOA†	Oak Signature Panels - Single Door, Two Trays per Slide	—	1 ea
DXSUSIGNLOGO	Signature Logo (4 Logos Per Set)	—	—
DXSUSIGNCUSTOM	Signature Custom Panels	—	—
DXSUSIGNPEDIAT	Signature Panels Pediatrics Without Logo	—	—
Other Options			
DXSUPQC48	TQ Supreme - 8" Quiet Caster Upgrade	—	1 ea
DXSUPSDL	TQ Supreme - Transport Latch	—	—
Prod No	Description	Color	Pack
Coldmaster CoolCheck & Accessories			
DXCM1100C14	6" Deep Full-Size Food Pan	02	1 ea
DXCM1125	Full-Size Lid	07	2 ea
DXCM1101C14	6" Deep Half-Size Food Pan	02	1 ea
DXCM1126	Half-Size Lid	07	2 ea
10601	12" x 18" Service Mat – Black	03	6 ea
Prod No	Description	L x D x H	Pack
Dome Condiment Center			
BD4003**	Dome Condiment Center (3) 2 qt. 2 handles	22" x 7.5" x 8.5"	1 ea
BD4004**	Dome Condiment Center (4) 3 pt. deep trays 2 handles	22" x 7.5" x 8.5"	1 ea

Dinex by CFS Brands NSF Listed products are designated with a ▲ and may be prefixed with an N

*Includes the height of the four-sided top rail

**Must be ordered separately

†For Signature Panel option please add 6, 8, 10, 10PT, 12, 12PT, 16 or 20 at the end of the signature panel item number based on the cart capacity needed



TRAY DELIVERY CARTS

Quiet, heavy duty welded stainless steel cart for demanding meal delivery and improved patient satisfaction.

TQ cart is available in many different versions for a delivery of 6 to 36 trays.

- Sound dampening design
- All stainless steel construction
- Features heat release vented side panels
- Corner bumpers and vertical push handles are standard
- Gravity locking doors with door stop
- Removable tray racks



Product Specifications Can Be Customized

Shown with
DXCM1100C1402
Coldmaster CoolCheck



Dinex added noise reduction in the following areas:



Interchangeable Rack System

Adjustable to accommodate different size trays.



Removable Tray Slides

Light weight and easy to remove for cleaning.

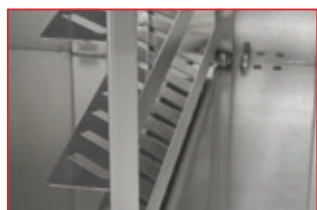

Rails & Ladders

Rails and ladders are locked in tight so they don't move while rolling.

Watch our video on the TQ Cart at www.carlislefsp.com/videos.

Additional Options:



Floor Drain



Wrap Around Bumpers

Protect surfaces and keep your cart looking newer longer.



DXTQ1T1D6
Shown with optional Top Rail



DXT02T2D20
Pass Thru Model

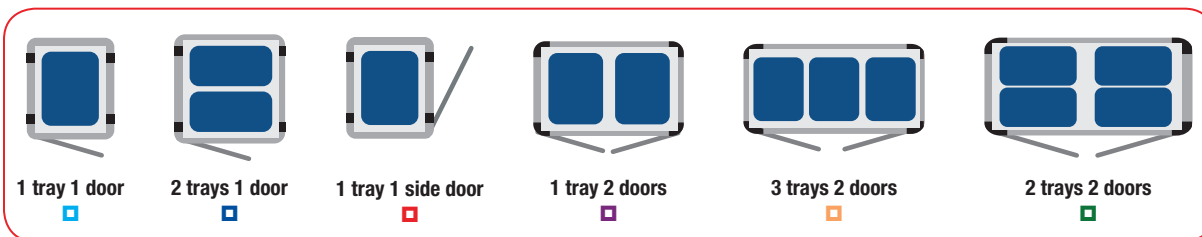

Prod No **Description** **L x D x H** **Pack**

TQ Quiet Carts Single Door Tray Delivery Carts With One Tray Per Slide
Casters: Four - 6" (2 rigid, 2 swivel w/Tech lock brakes)

DXTQ1T1D6	6 Tray Cart, Single Door, One Tray per Slide	25.64" x 27.58" x 45.06" / 65.1 x 70.1 x 114.5 cm	1 ea
DXTQ1T1D8	8 Tray Cart, Single Door, One Tray per Slide	25.64" x 27.58" x 55.80" / 65.1 x 70.1 x 141.7 cm	1 ea

TQ Quiet Carts Single Side Door Tray Delivery Cart with One Tray Per Slide
4.75" Tray Spacing Only Fits 14" x 18" and 15" x 20" Trays, 3-Sided Top Rail is Standard

DXTQ1T1DS9CC	9 tray cart, single side door, one tray per slide	23.15" x 29.64" x 56.41" / 58.8 x 75.28 x 143.28 cm	1 ea
--------------	---	---	------

TQ Quiet Carts Single Door Tray Delivery Carts With Two Trays Per Slide
Casters: Four - 6" (2 rigid, 2 swivel w/Tech lock brakes)

DXTQ2T1D10	10 Tray Cart, Single Door, Two Trays per Slide	31.64" x 36.21" x 39.79" / 80.4 x 92 x 101.1 cm	1 ea
DXTQ2T1DPT10	10 Tray Cart, Single Door, Two Trays per Slide, Pass Thru	31.64" x 36.21" x 39.79" / 80.4 x 92 x 101.1 cm	1 ea
DXTQ2T1D12	12 Tray Cart, Single Door, Two Trays per Slide	31.64" x 36.21" x 50.55" / 80.4 x 92 x 128.4 cm	1 ea
DXTQ2T1DPT12	12 Tray Cart, Single Door, Two Trays per Slide, Pass Thru	31.64" x 36.21" x 50.55" / 80.4 x 92 x 128.4 cm	1 ea
DXTQ2T1D14	14 Tray Cart, Single Door, Two Trays per Slide	31.64" x 36.21" x 50.55" / 80.4 x 92 x 128.4 cm	1 ea
DXTQ2T1DPT14	14 Tray Cart, Single Door, Two Trays per Slide, Pass Thru	31.64" x 36.21" x 50.55" / 80.4 x 92 x 128.4 cm	1 ea
DXTQ2T1D16	16 Tray Cart, Single Door, Two Trays per Slide	31.64" x 36.21" x 55.32" / 80.4 x 92 x 140.5 cm	1 ea
DXTQ2T1DPT16	16 Tray Cart, Single Door, Two Trays per Slide, Pass Thru	31.64" x 36.21" x 55.32" / 80.4 x 92 x 140.5 cm	1 ea
DXTQ2T1D18	18 Tray Cart, Single Door, Two Trays per Slide	31.64" x 36.21" x 66.30" / 80.4 x 92 x 168.4 cm	1 ea
DXTQ2T1DPT18	18 Tray Cart, Single Door, Two Trays per Slide, Pass Thru	31.64" x 36.21" x 66.30" / 80.4 x 92 x 168.4 cm	1 ea
DXTQ2T1D20	20 Tray Cart, Single Door, Two Trays per Slide	31.64" x 36.21" x 66.30" / 80.4 x 92 x 168.4 cm	1 ea
DXTQ2T1DPT20	20 Tray Cart, Single Door, Two Trays per Slide, Pass Thru	31.64" x 36.21" x 66.30" / 80.4 x 92 x 168.4 cm	1 ea

DOUBLE DOOR TQ CARTS

 **Product Specifications Can Be Customized**



DXTQ1T2D16



DXTQ2T2D24
Shown with optional top rail and optional 6 wheel configuration

For a complete list of optional cart upgrades, see page 147. All upgrades must be ordered at the same time as the cart.







Prod No	Description	L x D x H	Pack
TQ Quiet Carts (Double Door Tray Delivery Carts With One Tray Per Slide)			
Casters: Four - 6" (2 rigid, 2 swivel w/Tech lock brakes)			
DXTQ1T2D10	10 Tray Cart, Double Door, One Tray per Slide	44.14" x 27.58" x 45.06" / 112.1 x 70.1 x 114.5 cm	1 ea
DXTQ1T2D12	12 Tray Cart, Double Door, One Tray per Slide	44.14" x 27.58" x 45.06" / 112.1 x 70.1 x 114.5 cm	1 ea
DXTQ1T2D14	14 Tray Cart, Double Door, One Tray per Slide	44.14" x 27.58" x 55.80" / 112.1 x 70.1 x 141.7 cm	1 ea
DXTQ1T2D16	16 Tray Cart, Double Door, One Tray per Slide	44.14" x 27.58" x 55.80" / 112.1 x 70.1 x 141.7 cm	1 ea
DXTQ1T2D18	18 Tray Cart, Double Door, One Tray per Slide	44.14" x 27.58" x 66.30" / 112.1 x 70.1 x 168.4 cm	1 ea
DXTQ1T2D20	20 Tray Cart, Double Door, One Tray per Slide	44.14" x 27.58" x 66.30" / 112.1 x 70.1 x 168.4 cm	1 ea
TQ Quiet Carts (Three Bay - Double Door Tray Delivery Carts With One Tray Per Slide)			
Casters: Six - 6" (2 swivel, 2 rigid, 2 swivel w/Tech lock brakes)			
DXTQ1T2D3C21	21 Tray Cart, Double Door, One Tray per Slide, Three Bay	62.83" x 27.58" x 55.80" / 159.6 x 70.1 x 141.7 cm	1 ea
DXTQ1T2D3C24	24 Tray Cart, Double Door, One Tray per Slide, Three Bay	62.83" x 27.58" x 55.80" / 159.6 x 70.1 x 141.7 cm	1 ea
DXTQ1T2D3C27	27 Tray Cart, Double Door, One Tray per Slide, Three Bay	62.83" x 27.58" x 66.30" / 159.6 x 70.1 x 168.4 cm	1 ea
DXTQ1T2D3C30	30 Tray Cart, Double Door, One Tray per Slide, Three Bay	62.83" x 27.58" x 66.30" / 159.6 x 70.1 x 168.4 cm	1 ea
TQ Quiet Carts (Double Door Tray Delivery Carts With Two Trays Per Slide)			
Casters: Four - 6" (2 swivel, 2 swivel w/Tech lock brakes)			
DXTQ2T2D20	20 Tray Cart, Double Door, Two Trays per Slide	56.14" x 36.26" x 39.79" / 142.6 x 92.1 x 101.1 cm	1 ea
DXTQ2T2DPT20	20 Tray Cart, Double Door, Two Trays per Slide, Pass Thru	56.14" x 36.26" x 39.79" / 142.6 x 92.1 x 101.1 cm	1 ea
DXTQ2T2D24	24 Tray Cart, Double Door, Two Trays per Slide	56.14" x 36.26" x 50.55" / 142.6 x 92.1 x 128.4 cm	1 ea
DXTQ2T2DPT24	24 Tray Cart, Double Door, Two Trays per Slide, Pass Thru	56.14" x 36.26" x 50.55" / 142.6 x 92.1 x 128.4 cm	1 ea
DXTQ2T2D28	28 Tray Cart, Double Door, Two Trays per Slide	56.14" x 36.26" x 50.55" / 142.6 x 92.1 x 128.4 cm	1 ea
DXTQ2T2DPT28	28 Tray Cart, Double Door, Two Trays per Slide, Pass Thru	56.14" x 36.26" x 50.55" / 142.6 x 92.1 x 128.4 cm	1 ea
DXTQ2T2D32	32 Tray Cart, Double Door, Two Trays per Slide	56.14" x 36.26" x 61.05" / 142.6 x 92.1 x 155.1 cm	1 ea
DXTQ2T2DPT32	32 Tray Cart, Double Door, Two Trays per Slide, Pass Thru	56.14" x 36.26" x 61.05" / 142.6 x 92.1 x 155.1 cm	1 ea
DXTQ2T2D36	36 Tray Cart, Double Door, Two Trays per Slide	56.14" x 36.26" x 61.05" / 142.6 x 92.1 x 155.1 cm	1 ea
DXTQ2T2DPT36	36 Tray Cart, Double Door, Two Trays per Slide, Pass Thru	56.14" x 36.26" x 61.05" / 142.6 x 92.1 x 155.1 cm	1 ea



TQ QUIET CC VERSION

TQ Quiet CC version has been designed to accommodate 15 x 20 and 14 x 18 tray sizes only. The cart is more compact than a regular TQ cart and also shorter because it features a tray spacing of 4.75"



Prod No	Description	L x D x H	Pack
TQ Cart CC Version – 4.75" Tray Spacing, Accommodates 14" x 18", 15" x 20"			
Casters: Four - 6"			
DXTQ2T1D10CC 	10 Tray Cart, Single Door, Two Trays per Slide	35.07" x 29.64" x 37.35" / 89.1 x 75.3 x 94.9 cm	1 ea
DXTQ2T1D16CC 	16 Tray Cart, Single Door, Two Trays per Slide	35.07" x 29.64" x 51.6" / 89.1 x 75.3 x 131.1 cm	1 ea
DXTQ2T1D20CC 	20 Tray Cart, Single Door, Two Trays per Slide	35.07" x 29.64" x 61.1" / 89.1 x 75.3 x 156.5 cm	1 ea
TQ Cart CC Version – 4.75" Tray Spacing, Accommodates 14" x 18", 15" x 20"			
Casters: Four - 6"			
DXTQ2T2D24CC 	28 Tray Cart, Double Door, Two Trays per Slide	53.14" x 35.09" x 42.18" / 135 x 89.1 x 107.1 cm	1 ea
DXTQ2T2D28CC 	28 Tray Cart, Double Door, Two Trays per Slide	53.14" x 35.09" x 46.93" / 135 x 89.1 x 119.2 cm	1 ea
DXTQ2T2D32CC 	36 Tray Cart, Double Door, Two Trays per Slide	53.14" x 35.09" x 51.68" / 135 x 89.1 x 131.3 cm	1 ea

TQ Quiet Cart Options

- Top rail, 3 sided
- Top rail, 4 sided
- Wrap around bumper
- Floor drain (one drain per door)
- Transport latch
- Menu holder

TQ Quiet Cart Caster Upgrade Packages

- 8" Performa caster upgrade (set of 4)
- 8" Performa caster upgrade for all TQ1T2D3C (set of 6)
- 6" Performa, 5th wheel center
- 8" Performa, 5th wheel center
- 6" Performa, 5th wheel ahead
- 8" Performa, 5th wheel ahead
- 6" Performa caster upgrade (set of 6)
- 8" Performa caster upgrade (set of 6)

All upgrades must be ordered at the same time as the cart.

Product No	Description
Top Rails	
DXTQTOPR32T1D	Top Rail, Three Sides for all TQ2T1D Carts
DXTQTOPR32T2D	Top Rail, Three Sides for all TQ2T2D Carts
DXTQTOPR31T1D	Top rail, Three Sides for all 1T1D Carts
DXTQTOPR31T2D	Top Rail, Three Sides for all TQ2T1D Carts
DXTQTOPR31T2D3C	Top Rail, Three Sides for all TQ1T2D3C Carts
DXTQTOPR42T1D	Top Rail, Four Sides for all TQ2T1D Carts
DXTQTOPR42T2D	Top Rail, Four Sides for all TQ2T2D Carts
DXTQTOPR41T1D	Top Rail, Four Sides for all TQ1T1D
DXTQTOPR41T2D	Top Rail, Four Sides for all TQ1T2D Carts
DXTQTOPR41T2D3C	Top Rail, Four Sides for all TQ1T2D3C Carts
Accessories	
DXTQWB2T1D	Wrap-Around Bumper for all TQ2T1D Carts
DXTQWB2T2D	Wrap-Around Bumper for all TQ2T2D Carts
DXTQWB1T1D	Wrap-Around Bumper for all TQ1T1D Carts
DXTQWB1T2D	Wrap-Around Bumper for all TQ1T2D Carts
DXTQWB1T2D3C	Wrap-Around Bumper for all TQ1T2D3C Carts
DXTSWALLSAVER	Wallsaver Bumper for TQ Carts (Set of 4)
DXTSTOW	TQ Cart Tow Hitch Assembly 16095-2833/2834
DXTSDRAIN	Floor Drain Assembly (one drain per door)
DXTSLATCH	Transport Latch
DXTSMENU	Menu Holder
Caster Package Upgrades	
DXTSBP66	6" Performa (set of 6)
DXTSPFMA84	8" Performa Upgrade (set of 4)
DXTSBP68	8" Performa (set of 6)
DXTSPFMA86	8" Performa Upgrade (set of 6) - 3C Carts
DXTSBP5CNT6	6" Performa, 5th Wheel Center
DXTSBP5CNT8	8" Performa, 5th Wheel Center
DXTSBP5FRT6	6" Performa, 5th Wheel Ahead
DXTSBP5FRT8	8" Performa, 5th Wheel Ahead
DXTQCAST64S	6" (4) Swivel Casters (2) with Brakes
DXTQCAST84S	8" (4) Swivel Casters (2) with Brakes
DXTQCAST84P	8" Pneumatic Wheels (2) Fixed (2) Swivel with Brakes

Note: 8" Casters not available on DXTQ1T1D6 and DXTQ1T1D8 Models



TRAY DELIVERY CARTS

Light, compact and cost-efficient solution for traditional meal delivery and tray retrieval

TQ Economy Tray Delivery Carts

The TQ Economy delivery carts are designed for transport of patient meals to decentralized locations. The all stainless steel cart features fixed tray slides, 5-1/4" tray spacing that accommodates two each 14" x 18", 15" x 20" trays per slide and Dinx Room Service Tray DX1089RS152003.

Standard Features

- All stainless steel
- Magnetic pull type door handle
- Drop latch
- Small footprint
- Plate-type 5" casters, 2 with brakes
- NSF Listed

Options

- Wrap around bumper
- Corner bumpers
- Floor drains, one per door
- Push handle (available on single door units only)
- Top rails



All upgrades must be ordered at the same time as the cart.



DXICT16

 **Product Specifications Can Be Customized**



DXICT322D



DXICT10

Shown with optional Top Rails

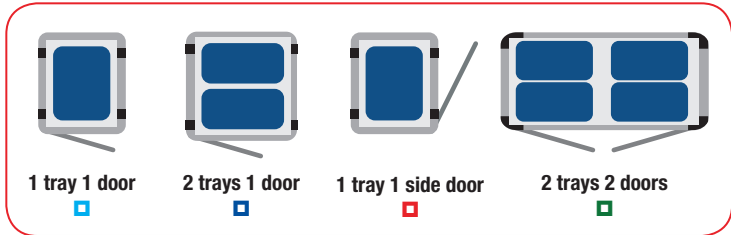



TQ Economy Tray Delivery Carts

Prod No	Description	Capacity	L x D x H	Pack
1 Tray, 1 Door Version				
TRAY SIZES: 14" x 18", 13" x 21", 15" x 20" and Dinex Room Service Tray				
DXICT6S ▲ ■	Room Service Cart, Enclosed	6	19.25" x 24.5" x 42.63" / 48.9 x 62.2 x 108.3 cm	1 ea
DXICT7S ▲ ■	Room Service Cart, Enclosed	7	19.25" x 24.5" x 48.25" / 48.9 x 62.2 x 122.5 cm	1 ea
DXICT8S ▲ ■	Room Service Cart, Enclosed	8	19.25" x 24.5" x 53.88" / 48.9 x 62.2 x 136.8 cm	1 ea
DXICT10S ▲ ■	Room Service Cart, Enclosed	10	19.25" x 24.5" x 65.13" / 48.9 x 62.2 x 165.4 cm	1 ea
1 Tray, 1 Side Door Version				
TRAY SIZES: 14" x 18", 15" x 20", Tray Spacing 4.75" and 3-Sided Top Rail is Standard				
DXICT11TDS9CC ▲ ■	Room Service Cart, Enclosed with Side Door	9	21.72 x 23.75 x 52.98" / 55.2 x 60.3 x 134.6 cm	1 ea
2 Tray, 1 Door Version				
TRAY SIZES: 14" x 18", 15" x 20" and Dinex Room Service Tray				
DXICT10 ▲ ■	Tray Cart, Enclosed	10	23.75" x 34.25" x 37.13" / 60.3 x 87 x 94.3 cm	1 ea
DXICTPT10 ▲ ■	Tray Cart, Enclosed, Pass Thru	10	23.75" x 34.25" x 37.13" / 60.3 x 87 x 94.3 cm	1 ea
DXICT12 ▲ ■	Tray Cart, Enclosed	12	23.75" x 34.25" x 42.75" / 60.3 x 87 x 108.6 cm	1 ea
DXICTPT12 ▲ ■	Tray Cart, Enclosed, Pass Thru	12	23.75" x 34.25" x 42.75" / 60.3 x 87 x 108.6 cm	1 ea
DXICT16 ▲ ■	Tray Cart, Enclosed	16	23.75" x 34.25" x 54" / 60.3 x 87.0 x 137.2 cm	1 ea
DXICTPT16 ▲ ■	Tray Cart, Enclosed, Pass Thru	16	23.75" x 34.25" x 54" / 60.3 x 87.0 x 137.2 cm	1 ea
DXICT20 ▲ ■	Tray Cart, Enclosed	20	23.75" x 34.25" x 65.25" / 60.3 x 87.0 x 165.7 cm	1 ea
DXICTPT20 ▲ ■	Tray Cart, Enclosed, Pass Thru	20	23.75" x 34.25" x 65.25" / 60.3 x 87.0 x 165.7 cm	1 ea
DXICT24 ▲ ■	Tray Cart, Enclosed	24	23.75" x 34.25" x 76.5" / 60.3 x 87.0 x 194.3 cm	1 ea
DXICTPT24 ▲ ■	Tray Cart, Enclosed, Pass Thru	24	23.75" x 34.25" x 76.5" / 60.3 x 87.0 x 194.3 cm	1 ea
2 Tray, 2 Door Version				
TRAY SIZES: 14" x 18", 15" x 20" and Dinex Room Service Tray				
DXICT202D ▲ ■	Tray Cart, Enclosed, 2 door	20	46.34" x 34.22" x 37.15" / 117.7 x 86.9 x 94.4 cm	1 ea
DXICTPT202D ▲ ■	Tray Cart, Enclosed, 2 door, Pass Thru	20	46.34" x 34.22" x 37.15" / 117.7 x 86.9 x 94.4 cm	1 ea
DXICT242D ▲ ■	Tray Cart, Enclosed, 2 door	24	46.34" x 34.22" x 42.75" / 117.7 x 86.9 x 108.7 cm	1 ea
DXICTPT242D ▲ ■	Tray Cart, Enclosed, 2 door, Pass Thru	24	46.34" x 34.22" x 42.75" / 117.7 x 86.9 x 108.7 cm	1 ea
DXICT282D ▲ ■	Tray Cart, Enclosed, 2 door	28	46.34" x 34.22" x 48.4" / 117.7 x 86.9 x 122.9 cm	1 ea
DXICTPT282D ▲ ■	Tray Cart, Enclosed, 2 door, Pass Thru	28	46.34" x 34.22" x 48.4" / 117.7 x 86.9 x 122.9 cm	1 ea
DXICT322D ▲ ■	Tray Cart, Enclosed, 2 door	32	46.34" x 34.22" x 54.03" / 117.7 x 86.9 x 137.2 cm	1 ea
DXICTPT322D ▲ ■	Tray Cart, Enclosed, 2 door, Pass Thru	32	46.34" x 34.22" x 54.03" / 117.7 x 86.9 x 137.2 cm	1 ea

TQ Economy Tray Cart Options

Prod No	Description	Capacity
Top Rails		
DXICTTR1	Top Rail, One Side for TQ Economy Carts	For 10 to 16 capacity carts
DXICTTR2	Top Rail, Two Sides for TQ Economy Carts	For 10 to 16 capacity carts
DXICTTR3	Top Rail, Three Sides for TQ Economy Carts	For 10 to 16 capacity carts
DXICTTR4	Top Rail, Four Side for TQ Economy Carts	For 10 to 16 capacity carts
DXICT2DTR3	Top Rail, Three Sides for TQ Economy Carts	For 20 to 32 capacity carts
DXICT3DTR4	Top Rail, Four Sides for TQ Economy Carts	For 20 to 32 capacity carts
Accessories		
DXICTWB	Wrap-Around Bumpers for TQ Economy Carts	—
DXICTCB	Corner bumpers for TQ Economy Carts	—
DXICTCC	Carafe Caddy for TQ Economy Carts	For all capacity carts
DXICTDRAIN	Drain Assembly for TQ Economy Carts - One Per Door	—
DXICTPH	Push Hhandle for TQ Economy Carts	For 16, 20 and 24 capacity carts
DXICTTOW	Tow Hitch for TQ Economy Carts	—
Caster Upgrade Packages		
DXICTCAST6	6" Caster Upgrade for ICT Carts	—
DXICTCAST8	8" Caster Upgrade for ICT Carts	—
DXICTCAST54S	5" (4) Swivel Casters (2) with Brakes	—
DXICTCAST64S	6" (4) Swivel Casters (2) with Brakes	—
DXICTCAST84P	8" Pneumatic Caster (2) Fixed Casters (2) Swivel with Brake	—

Dinex by CFS Brands NSF Listed products are designated with a ▲ and may be prefixed with an N



TRAY DELIVERY CARTS

Specialty Tray Delivery Cart - Accommodates Special Tray Sizes

The Specialty Tray Delivery Cart is designed for transporting meals or tray retrieval. Often bundled with Thermal-Aire carts and Meals On Command carts as a soiled tray pick-up solution, the tray delivery cart features fixed tray slides with 5-1/4" spacing and accommodates 2 trays/slide. This cart will accommodate 13"x 21" Retherm trays as well as the Architectural Plastics BA5B Room Service Tray.



Product Specifications
Can Be Customized

Standard Features

- All stainless steel
- Magnetic pull type door handle
- Drop latch
- Small footprint
- Plate-type 5" casters, 2 with brakes
- NSF Listed

Options

- Wrap around bumper
- Corner bumpers
- Floor drains, one per door
- Push handle (available on single door units only)
- Top rails



DXPSC16



DXPSC322D

All upgrades must be ordered at
the same time as the cart.



Specialty Tray Delivery Carts

Prod No	Description	Capacity	L x D x H	Pack
---------	-------------	----------	-----------	------

TQ Economy Carts**TRAY SIZES: (13" x 21") (Retherm) and Dinex Room Service Tray**

DXPSC10 Δ	Tray Cart, Enclosed	10	25.25" x 34.22" x 35.57" / 64.1 x 86.9 x 90.3 cm	1 ea
DXPSCPT10 Δ	Tray Cart, Enclosed, Pass Thru	10	25.25" x 34.22" x 35.57" / 64.1 x 86.9 x 90.3 cm	1 ea
DXPSC12 Δ	Tray Cart, Enclosed	12	25.25" x 34.22" x 40.91" / 64.1 x 86.9 x 103.9 cm	1 ea
DXPSCPT12 Δ	Tray Cart, Enclosed, Pass Thru	12	25.25" x 34.22" x 40.91" / 64.1 x 86.9 x 103.9 cm	1 ea
DXPSC14 Δ	Tray Cart, Enclosed	14	25.25" x 34.22" x 46.25" / 64.1 x 86.9 x 117.5 cm	1 ea
DXPSCPT14 Δ	Tray Cart, Enclosed, Pass Thru	14	25.25" x 34.22" x 46.25" / 64.1 x 86.9 x 117.5 cm	1 ea

TQ Economy Carts**TRAY SIZES: (13" x 21") Retherm and Architectural Plastics* and Dinex Room Service Tray**

DXPSC16 Δ	Tray Cart, Enclosed	16	25.25" x 34.22" x 52.88" / 64.1 x 86.9 x 134.3 cm	1 ea
DXPSCPT16 Δ	Tray Cart, Enclosed, Pass Thru	16	25.25" x 34.22" x 52.88" / 64.1 x 86.9 x 134.3 cm	1 ea
DXPSC20 Δ	Tray Cart, Enclosed	20	25.25" x 34.22" x 63.56" / 64.1 x 86.9 x 161.4 cm	1 ea
DXPSCPT20 Δ	Tray Cart, Enclosed, Pass Thru	20	25.25" x 34.22" x 63.56" / 64.1 x 86.9 x 161.4 cm	1 ea
DXPSC24 Δ	Tray Cart, Enclosed	24	25.25" x 34.22" x 74.25" / 64.1 x 86.9 x 188.6 cm	1 ea
DXPSCPT24 Δ	Tray Cart, Enclosed, Pass Thru	24	25.25" x 34.22" x 74.25" / 64.1 x 86.9 x 188.6 cm	1 ea

TQ Economy Carts**TRAY SIZES: Architectural Plastics* and Dinex Room Service Tray**

DXPSC202D Δ	Tray Cart, Enclosed, 2 door	20	49.31" x 34.22" x 35.6" / 125.2 x 86.9 x 90.4 cm	1 ea
DXPSCPT202D Δ	Tray Cart, Enclosed, 2 door, Pass Thru	20	49.31" x 34.22" x 35.6" / 125.2 x 86.9 x 90.4 cm	1 ea
DXPSC242D Δ	Tray Cart, Enclosed, 2 door	24	49.31" x 34.22" x 40.95" / 125.2 x 86.9 x 104 cm	1 ea
DXPSCPT242D Δ	Tray Cart, Enclosed, 2 door, Pass Thru	24	49.31" x 34.22" x 40.95" / 125.2 x 86.9 x 104 cm	1 ea
DXPSC282D Δ	Tray Cart, Enclosed, 2 door	28	49.31" x 34.22" x 46.29" / 125.2 x 86.9 x 117.6 cm	1 ea
DXPSCPT282D Δ	Tray Cart, Enclosed, 2 door, Pass Thru	28	49.31" x 34.22" x 46.29" / 125.2 x 86.9 x 117.6 cm	1 ea
DXPSC322D Δ	Tray Cart, Enclosed, 2 door	32	49.31" x 34.22" x 51.64" / 125.2 x 86.9 x 131.2 cm	1 ea
DXPSCPT322D Δ	Tray Cart, Enclosed, 2 door, Pass Thru	32	49.31" x 34.22" x 51.64" / 125.2 x 86.9 x 131.2 cm	1 ea

Specialty Tray Delivery Cart Options

Prod No	Description	Capacity
---------	-------------	----------

Top Rails

DXPSCTR1	Top Rail, One Side for TQ Economy Carts	For 10 to 16 capacity carts
DXPSCTR2	Top Rail, Two Sides for TQ Economy Carts	For 10 to 16 capacity carts
DXPSCTR3	Top Rail, Three Sides for TQ Economy Carts	For 10 to 16 capacity carts
DXPSCTR4	Top Rail, Four Sides for TQ Economy Carts	For 10 to 16 capacity carts
DXPSC2DTR3	Top Rail, Three Sides for TQ Economy Carts	For 20 to 32 capacity carts
DXPSC3DTR4	Top Rail, Four Sides for TQ Economy Carts	For 20 to 32 capacity carts

Accessories

DXPSCWB	Wrap-Around Bumpers for TQ Economy Carts	—
DXPSCCB	Corner Bumpers for TQ Economy Carts	—
DXPSCDRAIN	Drain Assembly for TQ Economy Carts	—
DXPSCPH	Push Handle for TQ Economy	For 16 to 24 capacity carts

Caster Upgrade Packages

DXPSCCAST6	6" Caster Upgrade for PSC Carts	For 16 to 32 capacity carts
DXPSCCAST8	8" Caster Upgrade for PSC Carts	For 16 to 32 capacity carts
DXICTCAST54S	5" (4) Swivel Casters (2) with Brakes	
DXICTCAST64S	6" (4) Swivel Casters (2) with Brakes	
DXICTCAST84P	8" Pneumatic Caster (2) Fixed Casters (2) Swivel with Brakes	

Dinex by CFS Brands NSF Listed products are designated with a Δ and may be prefixed with an N

*Note: Architectural Plastics is a registered name



TRAY DELIVERY CARTS

TVL Economy Tray Delivery Carts Stainless steel cart for the price of plastic for meal delivery and tray retrieval

- Single door tray delivery cart with an all stainless steel modular construction
- TVL Carts are designed to hold multiple tray sizes: 14" x 18", 15" x 20", 12" x 19", 12"x 20" and DXRST1520 Room Service Tray
- Standard 5" tray height spacing
- Drop down latch for doors
- Perimeter bumper frame
- All options are field adjustable, except floor drains
- Bottom mounted floor drain
- Interchangeable rack system adjusts to accommodate different size trays
- Comes with 5" Performa casters with sealed stainless steel bearings (2 rigid, 2 swivel with side lock brakes)
- Optional Second Door
- Optional 3-side top rail
- NSF Listed



DXTVL2T1D10
Shown with optional Top Rail

Prod No	Description	Capacity	L x D x H	Pack
---------	-------------	----------	-----------	------

TVL Economy Tray Cart

TRAY SIZES: 14" x 18", 15" x 20", 12" x 19", 12" x 20", DXRST152, DXRST1520NSQ

DXTVL2T1D10 Δ	Tray Cart, Enclosed, 1 door	10	27.72" x 38.12" x 34.83" / 70.4 x 71.4 x 88.5 cm	1 ea
DXTVL2T1D12 Δ	Tray Cart, Enclosed, 1 door	12	27.72" x 38.12 x 39.83" / 70.4 x 71.4 x 101.2 cm	1 ea
DXTVL2T1D14 Δ	Tray Cart, Enclosed, 1 door	14	27.72" x 38.12 x 44.83" / 70.4 x 71.4 x 113.9 cm	1 ea
DXTVL2T1D16 Δ	Tray Cart, Enclosed, 1 door	16	27.72" x 38.12 x 49.83" / 70.4 x 71.4 x 126.6 cm	1 ea
DXTVL2T1D18 Δ	Tray Cart, Enclosed, 1 door	18	27.72" x 38.12 x 54.83" / 70.4 x 71.4 x 138.3 cm	1 ea
DXTVL2T1D20 Δ	Tray Cart, Enclosed, 1 door	20	27.72" x 38.12 x 59.83" / 70.4 x 71.4 x 152 cm	1 ea

Options

DXTVLTR3	Top Rail, Three Sides for TVL Carts	For 10 to 20 capacity carts		—
DXTVLDOR10	Door Assembly for TVL2T1D10	—	—	—
DXTVLDOR12	Door Assembly for TVL2T1D12	—	—	—
DXTVLDOR14	Door Assembly for TVL2T1D14	—	—	—
DXTVLDOR16	Door Assembly for TVL2T1D16	—	—	—
DXTVLDOR18	Door Assembly for TVL2T1D18	—	—	—
DXTVLDOR20	Door Assembly for TVL2T1D20	—	—	—

Caster Upgrade Packages

DXTQCAST54S	5" (4) Swivel Casters (2) with Brake			
-------------	--------------------------------------	--	--	--

Dinex by CFS Brands NSF Listed products are designated with a Δ and may be prefixed with an N



Versatile, Multi-Use Aluminum Carts

- Lightweight and versatile delivery cart
- Open style with optional transport cover
- Ideal for shelving or any immediate tray delivery system
- Welded aluminum construction
- Bolster mount casters for durability
- NSF Listed



DXDHOR12UP

All upgrades must be ordered at the same time as the cart.

Prod No	Description	Capacity	L x D x H	Pack
Heavy Duty Open Aluminum Tray Delivery Carts				
DXDHOR12UP	Tray Cart with Universal Tray Slides	12	25.28" x 32.94" x 38.33"	1 ea
DXDHOR20UP	Tray Cart with Universal Tray Slides	20	25.28" x 32.94" x 59.40"	1 ea
DXDHOR24UP	Tray Cart with Universal Tray Slides	24	25.28" x 32.94" x 69.33"	1 ea
Clear Vinyl Transport Covers For Room Service Carts				
DXDHOR12UCOVR ♦	Zippered Front Panel	—	—	1 ea
DXDHOR12UCOVR2 ♦	Zippered Front and Rear Panel	—	—	1 ea

♦ California Residents: Di(2-ethylhexyl)phthalate(DEHP) **WARNING:** See appendix B on page 281



DINEX

EFFICIENT VERSATILE PRODUCTIVE **STARTER STATIONS & CONVEYORS**

Starter stations and conveyors are at the heart of an efficient Meal Assembly set up. Only Dinx offers configurations to fit your needs and work seamlessly with our trays and wares for a total solution.





STARTER/CHECKER STATIONS

Mini Starter or Checker Station For Room Service POD Systems

Only Dinx brings you this **unique solution to drive space** and labor productivity.

- 30" x 24" footprint is ideal for room service pod systems
- Also works great as a checker station for those little items often missed, keeps your trayline moving
- Constructed of durable stainless steel
- **Adjustable shelving** with 4 different heights
- Comes with 6 plastic bins for organizing utensils and condiments
- Available with or without casters
- NSF Listed



DXICATABLESS



DXICATABLEMSS – Mini Starter Station with locking casters



 Product Specifications Can Be Customized



4 height adjustments to customize for your needs

Prod No	Description	L X D X H	Pack
Adjustable Mini Starter/Checker Station			
DXICATABLESS Δ	Mini Starter Station (Stationary with Leveling Feet)	30" x 24" x 60.75" / 76.20 x 60.96 x 154.31 cm	1 ea
DXICATABLEMSS Δ	Mini Starter Station (Mobile with Locking Casters)	30" x 24" x 60.75" / 76.20 x 60.96 x 154.31 cm	1 ea

Dinx by CFS Brands NSF Listed products are designated with a Δ and may be prefixed with an N



Starter/Checker Stations

- Dinex Starter Station increases productivity by providing a more efficient system of dispensing condiments and flatware onto patient trays
- Starter Stations are designed to roll alongside the trayline or cantilever over the top
- Comes with plastic bins to organize utensils and condiments



Cantilever Style

 Product Specifications
Can Be Customized



Straddle Style



Customized Table

Prod No **Description** **Pack**

Starter Stations

DXISS60	Starter Station (Straddle Style) 7 Bins, 60" (152.4 cm) Long	1 ea
DXISS72	Starter Station (Straddle Style) 8 Bins, 72" (182.9 cm) Long	1 ea
DXTMPSTARTER	Starter Station (Cantilever Style) 5 Bins, 43.75" (111.1 cm) Long	1 ea

Starter Station Accessories

DXTMP30-176	Plastic Bin Divider	1 ea
DXTMP30-240	Plastic Bin	1 ea



CONVEYORS



Conveyors

- Dinx Conveyors provide a **smooth, dependable trayline operation**
- Conveyors come in a variety of configurations: PVC Roller, Skate Wheel, Fabric Belt, Slat Belt, and Band Belt
- A wide variety of options and accessories are available



Product Specifications Can Be Customized

Cantilever Conveyors

Standard Features:

- 3" diameter casters
- Adjustable height
- Stainless steel upright
- Stainless steel frame

Options:

- Removable sections
- Field joint



Skate Wheel Conveyors

Options:

- Electric raceway
- Outlets
- Casters
- Field joint
- Movable over-shelf



PVC Roller Conveyors

Options:

- Electric raceway
- Outlets
- Casters
- Field joint
- Movable over-shelf





Fabric Belt Conveyors

Options:

- Electric raceway
- Outlets
- Casters
- Field joint
- Movable over-shelf
- Belt wash system



Product Specifications
Can Be Customized



All upgrades must be ordered at the same time as the product.

Prod No	Description	Section Size
---------	-------------	--------------

Cantilever Conveyors

DXIESRC4	Cantilever Conveyor, PVC Roller	4 ft / 1.2 m
DXIESRC5	Cantilever Conveyor, PVC Roller	5 ft / 1.5 m
DXIESRC6	Cantilever Conveyor, PVC Roller	6 ft / 1.8 m
DXIESRC7	Cantilever Conveyor, PVC Roller	7 ft / 2.1 m
DXIESRC8	Cantilever Conveyor, PVC Roller	8 ft / 2.4 m

Skate Wheel Conveyors

DXIESSW10	Skate Wheel Conveyor	10 ft / 3.05 m
DXIESSW12	Skate Wheel Conveyor	12 ft / 3.6 m
DXIESSW14	Skate Wheel Conveyor	14 ft / 4.3 m
DXIESSW16	Skate Wheel Conveyor	16 ft / 4.9 m
DXIESSW18	Skate Wheel Conveyor	18 ft / 5.5 m
DXIESSW20	Skate Wheel Conveyor	20 ft / 6.1 m

PVC Roller Conveyors

DXIESR10	PVC Roller Conveyor	10 ft / 3.05 m
DXIESR12	PVC Roller Conveyor	12 ft / 3.6 m
DXIESR14	PVC Roller Conveyor	14 ft / 4.2 m
DXIESR16	PVC Roller Conveyor	16 ft / 4.9 m
DXIESR18	PVC Roller Conveyor	18 ft / 5.5 m
DXIESR20	PVC Roller Conveyor	20 ft / 6.1 m

Fabric Belt Conveyors

DXIESFB8	Fabric Belt Conveyor	8 ft / 2.4 m
DXIESFB10	Fabric Belt Conveyor	10 ft / 3.05 m
DXIESFB12	Fabric Belt Conveyor	12 ft / 3.6 m
DXIESFB14	Fabric Belt Conveyor	14 ft / 4.3 m
DXIESFB16	Fabric Belt Conveyor	16 ft / 4.9 m
DXIESFB18	Fabric Belt Conveyor	18 ft / 5.5 m
DXIESFB20	Fabric Belt Conveyor	20 ft / 6.1 m



CONVEYORS

Slat Belt Conveyors

Options:

- Electric raceway
- Outlets
- Casters
- Field joint
- Movable over-shelf
- Belt wash system



**Product Specifications
Can Be Customized**

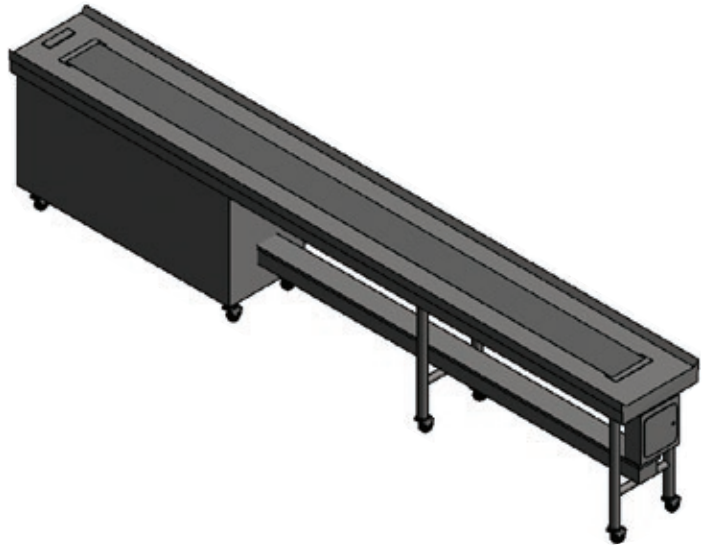

Band Belt Conveyors

Options:

- Electric raceway
- Outlets
- Casters
- Field joint
- Movable over-shelf
- Belt wash system

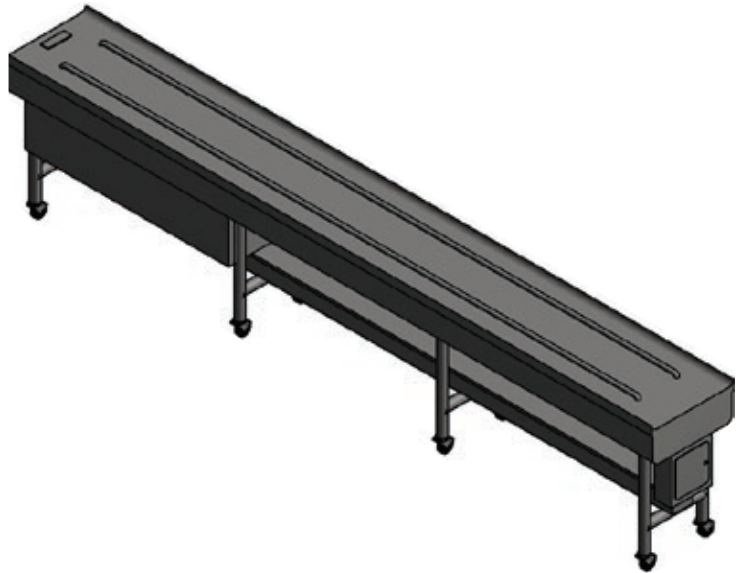

Prod No	Description	Section Size
---------	-------------	--------------

Slat Belt Conveyors

DXIESSB8	Slat Belt Conveyor	8 ft / 2.4 m
DXIESSB10	Slat Belt Conveyor	10 ft / 3.05 m
DXIESSB12	Slat Belt Conveyor	12 ft / 3.6 m
DXIESSB14	Slat Belt Conveyor	14 ft / 4.3 m
DXIESSB16	Slat Belt Conveyor	16 ft / 4.9 m
DXIESSB18	Slat Belt Conveyor	18 ft / 5.5 m
DXIESSB20	Slat Belt Conveyor	20 ft / 6.1 m

Band Belt Conveyors

DXIESB8	Band Belt Conveyor	8 ft / 2.4 m
DXIESB10	Band Belt Conveyor	10 ft / 3.05 m
DXIESB12	Band Belt Conveyor	12 ft / 3.6 m
DXIESB14	Band Belt Conveyor	14 ft / 4.3 m
DXIESB16	Band Belt Conveyor	16 ft / 4.9 m
DXIESB18	Band Belt Conveyor	18 ft / 5.5 m
DXIESB20	Band Belt Conveyor	20 ft / 6.1 m



All upgrades must be ordered at the same time as the product.

Prod No Description

Conveyor Options

DXIES01PH	Single Phase Outlet
DXIES01PHT	Single Phase Outlet with Twist Lock
DXIES03PH	Three Phase Outlet
DXIES03PHT	Three Phase Outlet with Twist Lock
DXIESOAMP	125 / 200 Amp Service Upgrade
DXIESOBW	Belt Wash Station for Fabric & Slat Styles Only
DXIESOCP	Cord & Plug, 100 Amp, Maximum
DXIESOCS1	Casters - 6 Caster set for a 8 ft-12 ft / 2.5-3.6 m Unit (Not Available for 200 Amp Service or Larger)
DXIESOCS2	Casters - 8 Caster set for a 14 ft / 4.3 m or longer Unit (Not Available for 200 Amp Service or Larger)
DXIESOFJ	Field Joint, Bolted or Field Welded, Recommended for Longer than 10 ft / 3.05 m Length
DXIESOOS	Solid Stainless Steel Overhead Shelf Section, Per Foot Upgrade Charge
DXIESORS4	Removable Section for 4 ft Conveyor
DXIESORS5	Removable Section for 5 ft Conveyor
DXIESORS6	Removable Section for 6 ft Conveyor
DXIESORS7	Removable Section for 7 ft Conveyor
DXIESORS8	Removable Section for 8 ft Conveyor
DXIESORS9	Removable Section for 9 ft Conveyor
DXIESORS10	Removable Section for 10 ft Conveyor
DXIESORS12	Removable Section for 12 ft Conveyor
DXIESORS14	Removable Section for 14 ft Conveyor
DXIESORS16	Removable Section for 16 ft Conveyor
DXIESORS18	Removable Section for 18 ft Conveyor
DXIESORS20	Removable Section for 20 ft Conveyor
DXIESORU	Upgrade to Stainless Steel Rollers from PVC, Per Foot Upgrade Charge
DXIESORW8	Electric Raceway, 8 ft / 2.4 m
DXIESORW10	Electric Raceway, 10 ft / 3.05 m
DXIESORW12	Electric Raceway, 12 ft / 3.6 m
DXIESORW14	Electric Raceway, 14 ft / 4.3 m
DXIESORW16	Electric Raceway, 16 ft / 4.9 m
DXIESORW18	Electric Raceway, 18 ft / 5.5 m
DXIESORW20	Electric Raceway, 20 ft / 6.1 m



CARLISLE
FOODSERVICE PRODUCTS



ELEGANT
VERSATILE
DURABLE
BEAUTIFUL
**DINNERWARE
& DRINKWARE**

Carlisle offers a wide array of guest pleasing dinnerware choices that can coordinate with every type of venue and cuisine. Set your table with Carlisle and watch the savings stack up vs. traditional dinnerware. Our durable collections are designed to be beautiful and long-lasting.



Items in this section are purchased through Carlisle FoodService Products and will ship separately from Dinex orders. Please contact your local sales representative for more information.



MELAMINE DINNERWARE

Inspired by **classical design and nature**, Stadia blends clean lines with **subtle organic shapes** to delight the eye and add contemporary style to any tabletop. Incorporating **stadium-shaped bowls and coupe plates**, Stadia offers a **refreshing take on traditional design fused with a modern twist** on conventional white dinnerware.



Stadia

- Stadium-shaped bowls and coupe plates with organic shapes offer plating options for any table setting
- Made from heavy-weight melamine resistant to breaking, staining, chipping and cracking
- Look and feel of china without the replacement cost making Stadia a smart investment
- Refreshing neutrals of luminous white and warm grey-beige emphasize food presentation and coordinates with any tabletop décor
- Safe for temperatures up to 212°F
- Dishwasher safe; NSF Listed
- One-year limited warranty



Prod No	Description	Color	Pack
Stadia Dinnerware			
53000 Δ	10.5" Dinner Plate	02, 80	12 ea
53001 Δ	9" Salad Plate	02, 80	12 ea
53002 Δ	7.25" Bread and Butter Plate	02, 80	12 ea
53003 Δ	8.5" Pasta Plate	02, 80	12 ea
53004 Δ	9.5" Pasta Plate	02, 80	12 ea
53005 Δ	11.5" Pasta Plate	02, 80	12 ea
53006 Δ	12 oz Bowl	02, 80	12 ea
53007 Δ	32 oz Bowl	02, 80	12 ea
53008 Δ	52 oz Bowl	02, 80	12 ea
53009 Δ	13" x 17" Platter	02, 80	12 ea
53010 Δ	4 oz Sauce Cup	02, 80	24 ea
53011 Δ	2 oz Sauce Cup	02, 80	24 ea

NSF Listed products are designated with a Δ and may be prefixed with an N

Note: Melamine Dinnerware is not recommended for microwave



Mingle's swirl design draws attention to the center of the plate – **putting the focus on your culinary creations.**

Mingle

- Perfect for employee dining, pool & resort dining or any casual venue where durability is ideal
- Textured body and swirl design puts the focus on your culinary creations
- Base color mimics ceramics
- Safe for temperatures up to 212°F
- NSF Listed; dishwasher safe
- One-year limited warranty



Prod No	Description	Color	Pack
Mingle Dinnerware			
54001 Δ	11" Dinner Plate	13, 15, 17, 18, 46, 52	12 ea
54002 Δ	9" Salad Plate	13, 15, 17, 18, 46, 52	12 ea
54003 Δ	9", 28.5 oz Rimmed Soup	13, 15, 17, 18, 46, 52	6 ea
54004 Δ	7", 27 oz Ice Cream Bowl	13, 15, 17, 18, 46, 52	12 ea
54005 Δ	6", 17 oz Bowl	13, 15, 17, 18, 46, 52	12 ea
54007 Δ	7" Bread & Butter Plate	13, 15, 17, 18, 46, 52	12 ea
54018 Δ	5", 4.5 oz Fruit Bowl	13, 15, 17, 18, 46, 52	48 ea
54019 Δ	8", 35.5 oz Cereal Bowl	13, 15, 17, 18, 46, 52	12 ea

NSF Listed products are designated with a Δ and may be prefixed with an N
 Note: Melamine Dinnerware is not recommended for microwave



MELAMINE DINNERWARE

Dress your dining table with the **beauty and feel of porcelain** at a fraction of the price. Sierrus Dinnerware is a **medium weight** version of our popular Durus design. Mix and match Durus with Sierrus to make your budget go farther.

Sierrus™

- All purpose, medium-heavy weight dinnerware has the same design as our Durus® line
- Available in eight solid colors
- Made of heavy-duty, break-resistant melamine
- Safe for temperatures up to 212°F
- Two-year limited warranty
- NSF Listed; dishwasher safe



White(02)	Black(03)	Red(05)	Meadow Green(09)
Ocean Blue(14)	Honey Yellow(22)	Bone(42)	Sunset Orange(52)

Prod No	Description	Color	Pack
Sierrus Narrow Rim Plates			
33000 Δ	10.5" 3-Compartment Plate	02, 03, 05, 09, 14, 22, 42, 52	12 ea
33002 Δ	10.5" Dinner Plate	02, 03, 05, 09, 22, 42, 52	12 ea
33004 Δ	9" Dinner Plate	02, 03, 05, 09, 14, 22, 42, 52	24 ea
33006 Δ	7.25" Salad Plate	02, 03, 05, 09, 14, 22, 42, 52*	48 ea
33008 Δ	6.5" Pie Plate	02, 03, 05, 09*, 14, 22*, 42, 52	48 ea
Sierrus Wide Rim Plates			
33024 Δ	12" Dinner Plate	02, 03, 05, 09*, 14, 42, 52*	12 ea
33010 Δ	10.5" Dinner Plate	02, 05*, 09*, 14*, 22, 42, 52*	12 ea
33012 Δ	9" Dinner Plate	02, 03, 05, 09, 14, 22, 42, 52	24 ea
33016 Δ	7.5" Salad Plate	02, 05, 09*, 14, 22*, 42, 52	48 ea
33018 Δ	6.5" Pie Plate	02, 03, 05*, 09, 14*, 22, 42, 52*	48 ea
33020 Δ	5.5" Bread & Butter Plate	02, 03*, 05, 09, 14, 42, 52*	48 ea

NSF Listed products are designated with a Δ and may be prefixed with an N

Note: Melamine Dinnerware is not recommended for microwave

* Color available by special order only



White(02)	Black(03)	Red(05)	Meadow Green(09)
Ocean Blue(14)	Honey Yellow(22)	Bone(42)	Sunset Orange(52)

Prod No	Description	Color	Pack
Sierrus Platters			
33080 Δ	13.5" x 10.5" Oval Platter	02, 03, 05, 09, 14, 22, 42, 52*	12 ea
33082 Δ	12" x 9.25" Oval Platter	02, 03, 05, 09, 14, 22, 42, 52	12 ea
33086 Δ	9.5" x 7.25" Oval Platter	02, 03, 05, 09*, 14, 22, 42, 52*	24 ea
Sierrus Bowls & Cup			
33030 Δ	20 oz, 12" Chef Salad/Pasta Bowl	02, 03, 05, 14, 22, 42, 52*	12 ea
33032 Δ	16 oz, 7.5" Rimmed Bowl	02, 03, 05, 09, 14, 22, 42, 52*	24 ea
33034 Δ	13 oz, 9.25" Pasta/Soup/Salad Bowl	02, 03, 05, 09*, 14, 22, 42	24 ea
33036 Δ	12 oz, 7.25" Rimmed Bowl	02, 03, 05, 09, 14, 22, 42, 52	24 ea
33038 Δ	10 oz, 5.38" Rimmed Nappie Bowl	02, 03, 05, 09*, 14, 22, 42, 52	24 ea
33040 Δ	6 oz, 6" Rimmed Bowl	02, 03, 05, 09, 14, 22, 42, 52	48 ea
33042 Δ	4.5 oz, 4.75" Rimmed Fruit Bowl	02, 03, 05, 09, 14, 22, 42, 52	48 ea

NSF Listed products are designated with a Δ and may be prefixed with an N

Note: Melamine Dinnerware is not recommended for microwave

* Color available by special order only



CARAFES & PITCHERS

Stylish design makes **Cascata** Carafes the most **attractive** carafe you can choose for tabletops and buffets, while offering **convenience** and superior **functionality**.

Cascata Carafe

- Ergonomic shape is easy to hold and angled rim provides a drip-free pour
- Larger sizes can be used for water, juice or wine
- Smaller sizes are good for salad dressings, syrups, single-portion drinks and snack mix
- A green alternative to single-serve drinks
- Snap-on lids available in solid or hinged styles and fit .5, 1 and 1.5 Liter Carafes
- All sizes have capacity marks for portion control
- Durable polycarbonate looks like glass
- NSF Listed; dishwasher safe

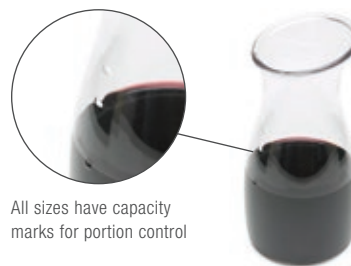

All sizes have capacity marks for portion control



Snap-on lids available in solid or hinged styles



Prod No	Description	Capacity Marks	Glass Rack	Color	Pack
Cascata Carafes & Lids					
70900 Δ \blacklozenge	0.25 Liter Carafe	6 oz, 8 oz, 0.25L	RG25-2, RW30-1	07	12 ea
70901 Δ \blacklozenge	0.50 Liter Carafe	0.5L	RG16-3, RW20-2	07	12 ea
70902 Δ \blacklozenge	1 Liter Carafe	1.0L	RG16-5	07	12 ea
70903 Δ \blacklozenge	1.5 Liter Carafe	1.5L	—	07	12 ea
70904 Δ	Flat Carafe Lid (fits 70901, 70902, 70903)	—	—	02	12 ea
70905 Δ	Hinged Carafe Lid (fits 70901, 70902, 70903)	—	—	02	12 ea

NSF Listed products are designated with a Δ and may be prefixed with an N

\blacklozenge California Residents: Bisphenol A **WARNING:** See appendix A on page 281



2 Cup Carafe

- Durable SAN 11 oz capacity carafe is perfect for room service, hospitals, nursing homes, restaurants and cafeterias
- Ribbed neck and textured finish provide a better grip and greater safety than glass bottles
- BPA free
- Dishwasher safe



Élan™ Polycarbonate Pitcher

- Thick walls and optic bottom gives these pitchers the look of glass
- Made of break-resistant polycarbonate
- Lid available separately
- Dishwasher safe



Clear(07)

Prod No	Description	Disposable Lid	Glass Rack	Color	Pack
2 Cup Carafe					
7000	11 oz Carafe	DX55-57*	RG16-2	07	36 ea
Élan Polycarbonate Pitcher & Lid					
5570 ♦	58 oz Élan Pitcher	—	RF	07	6 ea
5573 ♦	Clear Lid for Élan Pitcher	—	—	07	6 ea

Note: *The DX Series Disposable Lids listed above are available through the Carlisle | Dinex Catalog

♦ California Residents: Bisphenol A **WARNING:** See appendix A on page 281



MAXIMIZER™ PORTABLE BAR

Our easy care bar will delight your guests. Maximizer enables you to give your guests the bar service they want and expect. **It's great for dining halls or more intimate catered events.**

Ergonomic 2-step bar and countertop is designed for ease of drink preparation and serving; large surface area keeps condiment caddies within reach without blocking the prep area.

Maximizer Portable Bar

- Maximizer offers all the style and features you expect in a premium bar at a very affordable price
- Large 56" serving area keeps condiment caddies within reach without blocking prep area
- Durable solid molded countertop is easy to clean and includes a convenient molded-in bar mat well
- Sturdy 5" non-marking swivel casters with locking brake on each end hold the bar securely in place during use
- 15-gallon ice bin features an integrated drain and water trap
- Ice bin includes a standard dust cover for sanitary storage and transport
- Fully assembled, no tools necessary
- Find replacement parts at www.carlislefsp.com/replacement-parts



7550

Maximizer Cover

- Protective 8 gauge vinyl cover keeps bar clean and dry when not in use
- Double vented back secures with hook and loop tape for a custom fit
- Tape fastening allows easy access to bar storage area without removing cover

See our money saving coupon online at www.carlislefsp.com/ecoupons



Maximizer Portable Bar's upscale styling is at home in any setting



Prod No	Description	Color	Pack
Maximizer Portable Bar & Cover			
7550	Maximizer Portable Bar	03, 44, 094	1 ea
7555 ♦	Maximizer Bar Cover	80	1 ea

Find replacement parts at www.carlislefsp.com/replacement-parts

Note: 7550 cannot ship UPS/FedEx Ground

♦ California Residents: Di(2-ethylhexyl)phthalate (DEHP) **WARNING:** See appendix B on page 281

CONDIMENT CADDIES

Deluxe Caddies

- Solid frosted cover
- Includes caddy and individual containers

Plastic Caddies

- Solid frosted cover
- Includes caddy and individual containers



SS105



Tray Delivery Carts

page 138



Condiment Caddies help organize extra condiments needed during meal time delivery

Bar Mat & Service Mat

- Non-slip mats help keep counter tops clean
- Molded-in pattern provides drainage for spilled drinks and wash downs with a sure grip for wet glassware
- Bar Mats have drainage area for jigger, main area holds up to six glasses

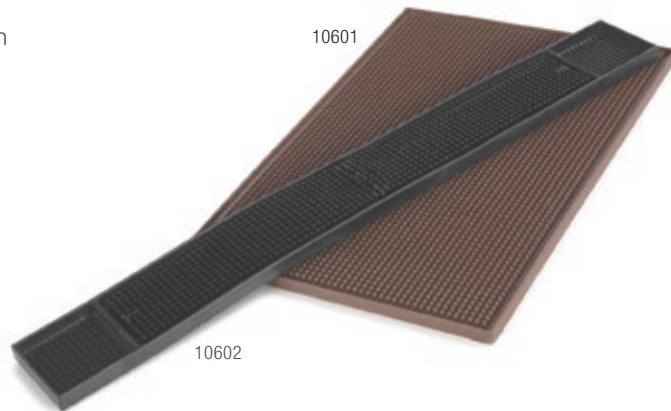

10601

10602



Prod No	Description	Color	Pack
Plastic Condiment Caddies			
SS105	Caddy with 5 ea 1.25 Pint Containers/Lids	02	1 ea
CH03 ♦	Deluxe Condiment Caddy with 6 ea Pint Containers	03	1 ea
CH15 ♦	Deluxe Condiment Caddy with 4 ea 1.5 Pint Containers	03	1 ea
Bar Mat & Service Mat			
10601	12" x 18" Service Mat	01, 03	6 ea
10602	3" x 27" Bar Mat	01, 03	12 ea

♦ California Residents: Bisphenol A **WARNING:** See appendix A on page 281



CARLISLE
FOODSERVICE PRODUCTS



BEAUTIFUL
QUALITY
ELEGANT
PROTECTIVE
HANDMADE
MARKO
TABLE
COVERINGS

*No room is complete without the finishing touches.
Setting an exceptional table begins with quality
products. Marko offers the finest quality of textiles to
help you achieve that perfect look.*



Items in this section are purchased through Carlisle FoodService Products and will ship separately from Dinex orders. Please contact your local sales representative for more information.

Let Marko's wide selection of table coverings add a **finishing touch** to your patient's dining area.

- Marko has a complete assortment of table coverings in easy care vinyl and upscale fabrics; from basic tablecloths to napkins, runners, and skirting, Marko can handle your request
- Many Marko items are stocked and can be added to your Carlisle order; check with your local sales person for a complete listing
- An even greater selection of Marko table coverings are made to order; ask your sales person for more details



How to Order:

Ask your local sales person for more information on Marko, or visit our website at www.carlislefsp.com/table-coverings

Add a warm feel to your dining room with Marko tablecloths and napkins. Both are washable and absorb liquids for easy cleanup and spill control; available in a full selection of complimentary colors.



Marko offers custom fit covers for feeding tables designed with a short drop for easy wheelchair access.



Vinyl tablecloths are available in multiple weights and price points to fit your budget. Everything from lightweight 4 gauge to premium 6 gauge vinyl with the drape of fabric. All vinyls are flame retardant and wipe clean with a soft, damp cloth.

Marko fabrics offer durability and elegance in a range of colors and weaves. The full line of tablecloths, napkins and skirting makes creating beautiful tables and buffets easier.



Napkins add an elegant, warm feel to your patient's dining experience. Marko offers popular Bistro Striped Napkins or a variety of solid colors designed to coordinate with fabric or vinyl tablecloths.





IN-STOCK PROGRAM

Includes the **most requested** Marko table coverings, napkins, skirting and accessories **available as stocked items**. With Carlisle FoodService, you can count on Marko to be there for you.

Embrace™

- Polyester/Spandex fabric embraces the table providing a snug fit and eliminating wrinkles
- True four-way stretch fabric easily expands over most tables for a uniform look
- Reinforced plastic feet come standard and are sewn in to hold the cover firmly in place
- Feet protect linens from contact with rough floor surfaces and help prevent ripping and soiling
- Serving as a functional linen, Embrace is perfect for beverage dispensers and waste receptacles
- Easy to install; no pressing or dry cleaning required
- Machine washable and dryable for easy care



EMB5026HT30

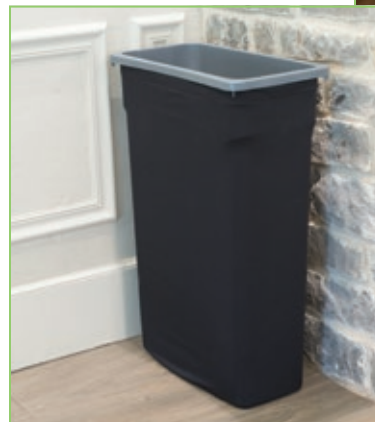

EMB5026TLC23

Embrace



Black(014)

Product No	Description	Finished Size	Color	Pack
Embrace				
EMB5026RT830	Embrace Rectangular Cover	96" x 30" x 30"	014	1 ea
EMB5026AC830	Embrace Arch Cut Cover	96" x 30" x 30"	014	1 ea
EMB5026RT630	Embrace Rectangular Cover	72" x 30" x 30"	014	1 ea
EMB5026AC630	Embrace Arch Cut Cover	72" x 30" x 30"	014	1 ea
EMB5026R72	Embrace Round Table Cover	72"	014	1 ea
EMB5026R24	Embrace Round Table Cover	24"	014	1 ea
EMB5026HT30	Embrace Hi-Top Round Table Cover	30"	014	1 ea
EMB5026TLC23	Embrace 23 gal TrimLine Cover	—	014	1 ea
EMB5026WC35	Embrace 32 gal Waste Container Cover	—	014	1 ea
EMB5026WC44	Embrace 44 gal Waste Container Cover	—	014	1 ea
EMB5026WC55	Embrace 55 gal Waste Container Cover	—	014	1 ea
EMB5026BS10	Embrace 10 gal Beverage Server Cover	—	014	1 ea
EMB5026BS5	Embrace 5 gal Beverage Server Cover	—	014	1 ea
EMB5026BS25	Embrace 2.5 gal Beverage Server Cover	—	014	1 ea
EMB5026LTRC	Embrace Tray Stand Cover, >30"	30"+	014	1 ea
EMB5026TRC	Embrace Tray Stand Cover, <30"	30"	014	1 ea
EMB5026TT27014	Embrace Tray Cover (Fits 27" x 22" Oval Tray)	28" x 33"	014	1 ea

SoftWeave™ Spun Filament Polyester Tablecloths & Napkins

- Spun filament polyester fabric (blend of polyspun and poly filament) provides the look and feel of cotton without fading or shrinking
- Excellent resistance to pilling and snagging
- Absorbs liquids quickly
- Advanced stain release technology allows you to wash at only 120°F water temperature and use half the detergent
- Aspen Damask, a Marko exclusive, has a high definition pattern that offers a bolder contrast



SoftWeave Tablecloth

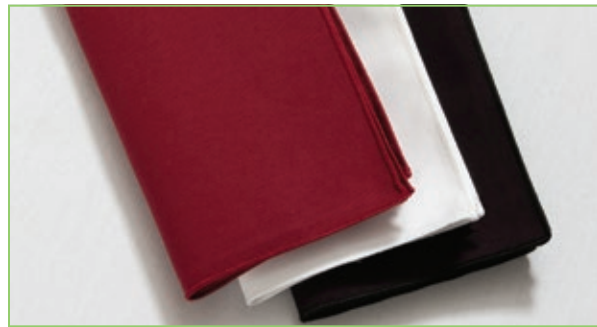

SoftWeave Napkins

SoftWeave



Aspen Damask

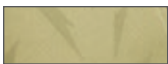

Sage(147)

Classic Twill



White(010)

Prod No	Description	Dimensions	Color	Pack
Fabric Tablecloths				
53785252SM	SoftWeave Square Tablecloth	52" x 52"	010, 014, 046	1 ea
537852AITM	SoftWeave Rectangular Tablecloth	52" x 108"	010, 046	1 ea
53785454SM	SoftWeave Square Tablecloth	54" x 54"	010	1 ea
537854AUTM	SoftWeave Rectangular Tablecloth	54" x 120"	010	1 ea
53785858SM	SoftWeave Square Tablecloth	58" x 58"	010	1 ea
53787272SM	SoftWeave Square Tablecloth	72" x 72"	010	1 ea
537876RM	SoftWeave Round Tablecloth	76"	010	1 ea
537890RM	SoftWeave Round Tablecloth	90"	010	1 ea
53935252SM	SoftWeave Aspen Damask Tablecloth	52" x 52"	147	1 ea



Classic Twill Skirting and Accessories

- Minimal fading, shrinking and wrinkling
- 100% Polyester; machine wash and dry
- Flame retardant
- Shirred skirts come complete with hook and loop tape and 550PC clips



Classic Twill Skirting w/ SoftWeave Tablecloth

Clips

Marko offers specifically designed clips to fit a variety of table edges. From our lifetime guarantee on our metal clips to our polycarbonate plastic clips, Marko has everything you need to pull your look together.



5CC55PC-12



5CC118MP-12



5CC120MP-12



5CC200PC-12



5CCCCLIP-12



5CCLCLIP-12

Classic Twill



White(010)



Black(014)

Prod No	Description	Dimensions	Color	Pack
Fabric Skirting				
5024CE29AF	Classic Twill Shirred Pleat Skirting w/Velcro Header & 24 Clips	13'	010, 014	1 ea
5024EG29AF	Classic Twill Shirred Pleat Skirting w/Velcro Header & 31 Clips	17.5'	010, 014	1 ea
5024FW29AF	Classic Twill Shirred Pleat Skirting w/Velcro Header & 38 Clips	21'	010, 014	1 ea
Skirting Accessories		Table Edge		
5CC55PC-12	Overlock & Valance Clip, Hook & Loop Header	1/2"	—	12 ea
5CC118MP-12	12 Metal Skirting Clip, Hook & Loop Header	3/8" - 1-1/4"	—	12 ea
5CC120MP-12	12 Metal Skirting Clip, Hook & Loop Header	1-1/4" - 2-1/4"	—	12 ea
5CC200PC-12	12 Plastic Skirting Clip, Hook & Loop Header	3/8" - 3/4"	—	12 ea
5CCCCLIP-12	12 Plastic Skirting Clip, Hook & Loop Header	3/4" - 2"	—	12 ea
5CCLCLIP-12	12 Large Plastic Skirting Clip, Hook & Loop Header	1-1/2" - 2-1/2"	—	12 ea

Bistro Striped Napkins

- Popular farm-to-table look
- 100% SoftWeave fabric
- Yarn dyed stripe stays true to color without fading or bleeding
- Designed to be washed with bleach



Bistro Striped Napkins

SoftWeave



White(010)



Black(014)



Burgundy(046)

Bistro Striped



Red(001)



Yellow(004)



Gold(008)



Black(014)



Maroon(023)



Purple(052)



Blue(062)



Kelly Green(064)

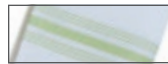

Lime Green(076)



Sage(147)



Raspberry(148)



Orange(414)



Metallic Gray(512)



Chocolate(515)



Belize Blue(630)

Aspen Damask Color

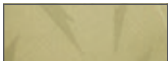

Sage(147)

Product No	Description	Finished Size	Color	Pack
Fabric Napkins				
53781717NM	SoftWeave Napkins	17" x 17"	010, 014, 046	12 ea
53782020NM	SoftWeave Napkins	20" x 20"	010, 014, 046	12 ea
53771822NH	SoftWeave Bistro Striped Napkin	18" x 22"	001, 004, 008, 014, 023, 052, 062, 064, 076, 147, 148, 414, 512, 515, 630	12 ea
53931717NM	Aspen Damask Napkins	17" x 17"	147	12 ea



Vinyl Table Coverings

Vative Series

- Premium vinyl line with the elegance and drape of fabric
- Heavy 6 gauge vinyl with polyester knit backing
- Flame retardant
- Easy care – simply wipe clean with a soft, damp cloth

Vative Glimmer Series

- Premium vinyl line with the elegance and drape of fabric; the “shimmering” color makes it perfect for weddings or upscale gatherings.
- Heavy 6 gauge vinyl with polyester knit backing
- Flame retardant
- Easy care – simply wipe clean with a soft, damp cloth

Classic Series

- Economical 4 gauge vinyl with polyester backing
- Flame retardant
- Easy care – simply wipe clean with a soft, damp cloth



Classic™ Series (Red Check)



Clear Vinyl

Clear Vinyl Rolls

- Protect your tabletops and expensive fabric tablecloths from moisture and spills
- BPA free
- Flexible material withstands repeated bending and pressure
- Use for multiple meal services – reduce laundry expenses and employee labor
- Excellent choice for long- or short-term care facilities with group dining environments
- A practical choice for large-scale craft projects in schools, daycares or DIY classes



Pan Rack Cover

Vative Series



Stone(382)

Vative Glimmer



Metallic Silver(625)

Classic Check



Red(001)

Clear Vinyl



Clear(018)

Misc. Vinyl



Clear(018)



Brown(005)



Black(014)

Product No	Description	Finished Size	Color	Pack
Vinyl Tablecloths				
59035252SM ♦	Vative Series	52" x 52"	382	1 ea
59085252SM ♦	Vative Series Glimmer Series	52" x 52"	625	1 ea
51515252SM ♦	Classic Series	52" x 52"	001	1 ea
Clear Vinyl				
53135054L	Clear Vinyl Roll, 4 Gauge, 54" Wide	50 yd	018	1 ea
53182554L	Clear Vinyl Roll, 8 Gauge, 54" Wide	25 yd	018	1 ea
53201554L	Clear Vinyl Roll, 12 Gauge, 54" Wide	15yd	018	1 ea
Misc. Vinyl				
5675CL ♦	Pan Rack Cover	N/A	018	1 ea

♦ California Residents: Di(2-ethylhexyl)phthalate (DEHP) **WARNING:** See appendix B on page 281

IN-STOCK PROGRAM DETAILS

Marko In-Stock items **can be combined with any foodservice product order** to meet freight minimums. Combined product orders will **ship together** from one distribution center

Return Policy:

- In-Stock items will offer the same 90-day return policy as foodservice
- All returns must be in original standard packs and unused, saleable condition
- See Carlisle Terms & Conditions for a complete list of requirements

Additional Ordering Information:

- In-Stock items can be combined on one purchase order with foodservice products
- In-Stock items can be combined with made-to-measure items
- Combined orders of In-stock items and made-to-measure items will ship together upon completion of the made-to-measure items

Note:

- Carlisle reserves the right to add or remove items from our stocking program at any time
- Made-to-measure items cannot be combined with foodservice orders

For more information, please contact your sales representative





CARLISLE
FOODSERVICE PRODUCTS



RUGGED BEAUTIFUL PORTABLE CONVENIENT **CATERING EQUIPMENT**

Carlisle's catering equipment line is the professionals' choice for your insulated transport needs. Only Carlisle Cateraides can offer attractive styling, longer hold times, and unique features that provide you superior value.



Items in this section are purchased through Carlisle FoodService Products and will ship separately from Dinex orders. Please contact your local sales representative for more information.



CATERAIDE™ IT

Introducing the **newly designed** CATERAIDE IT insulated transport line of products. IT is the only choice for foodservice professionals who demand they have it all. For the first time, rugged durability and industry leading safe food holding times are combined with **attractive, contemporary styling**. CATERAIDE IT sets a **new standard for value**.

Insulated Beverage Dispenser

- Heavy foam insulation holds temperatures in the safe zone for over 6 hours
- Field adjustable latches ensure a secure seal for the life of the carrier
- "Spring Action" faucet for no drip service
- Button-hole latch design offers convenient one hand operation and keeps the doors and lids closed tightly for better temperature retention
- Sure-grip handles promote a safe, stable, two-person lift for easy loading and unloading



IT500



IT500

Easily identify contents using the integrated writing surface



Higher spigot position allows for larger cups and mugs to fit underneath with ease



Prod No	Description	Color	Pack
CATERAIDE IT			
IT250 Δ	2.5 gal Beverage Dispenser	03, 43	1 ea
IT500 Δ	5 gal Beverage Dispenser	03, 43	1 ea
IT1000 Δ	10 gal Beverage Dispenser	03, 43	1 ea

NSF Listed products are designated with a Δ and may be prefixed with an N
Note: IT1000 can be shipped UPS/FedEx ground at oversize cost

End & Top Loader

- Holds six 2-1/2" deep food pans
- Heavy foam insulation holds temperatures in the safe zone for over 6 hours
- Secure stacking for easy transport and storage
- Sure-grip handles promote a safe, stable, two-person lift for easy loading and unloading
- Exclusive, low-profile, double hinge opens 270° for easy loading and unloading; lies flat to save space and makes it less likely to break
- Field adjustable latches ensure a secure seal for the life of the carrier
- Door hinge can be removed for easy, thorough cleaning
- Built-in seal eliminates gaskets on end & top loaders
- Use with CaterCooler to help keep foods at ServeSafe® temps longer (shown on page 176)

ServeSafe® is a registered trademark of the National Restaurant Association



MeatimeXpress

page 84



Flat top design can be used as a prep surface when space is limited



Button-hole latch design offers convenient one hand operation



Exclusive double hinge opens 270°



IT410

4 rotating wheels give this dolly unmatched maneuverability



IT140



IT400



Prod No	Description	Color	Pack
Cateraide IT			
IT400 Δ	End Loader (six pan capacity)	03, 43, 62*	1 ea
IT140 Δ	4" Top Loader (holds one full size pan up to 4" deep)	03, 43	1 ea
IT160 Δ	6" Top Loader (holds one full size pan up to 6" deep)	03, 43	1 ea
IT180 Δ	8" Top Loader (holds one full size pan up to 8" deep)	03, 43	1 ea
IT410 Δ	End Loader Dolly with Casters	03	1 ea

NSF Listed products are designated with a Δ and may be prefixed with an N

Note: IT180, IT400 can be shipped UPS/FedEx ground at oversize cos

* Color available by special order only



CATERAIDE™

Pan Carriers

- Cateraide construction made of rugged, stain- and scratch-resistant polyethylene
- Filled with extra thick foam insulation for maximum temperature retention
- Exclusive automatic self-venting system eliminates unsanitary vent openings and easily lost vent caps
- Heat resistant to 200°F
- Find replacement parts at www.carlislefsp.com/replacement-parts
- NSF Listed



Insulated Sheet Pan & Tray Carrier

- Individual tracks accommodate seven 18" x 26" trays
- Use with sheet pans shown on page 191 of the Carlisle FoodService Products catalog
- NSF Listed

Insulated Top Loaders

- Accommodates all third, half, and full size food pans
- PC188N top loader holds up to 8" deep food pan

Insulated End Loader

- Individual track for each food pan
- PC300N end loader holds five 2.5" deep pans
- PC600N has twice the capacity of the PC300N
- PC600N's separate compartments enable you to put hot food in one; cold in the other
- Use with CaterCooler to help keep foods at ServeSafe® temps longer (shown on facing page)
- NSF Listed



Use with DuraPans or StorPlus Food Pans shown on pages 196-202

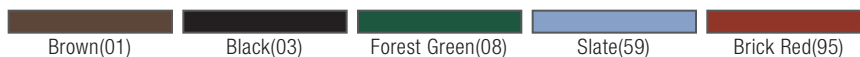

Prod No	Description	Color	Pack
Cateraide Insulated Top Loaders			
PC140N Δ	12 qt, 4" Single Pan Carrier	01, 03*	1 ea
PC160N Δ	18 qt, 6" Single Pan Carrier	01, 03	1 ea
PC180N Δ	24 qt, 8" Combination Pan Carrier	01, 03*	1 ea
Cateraide Insulated Sheet Pan & Tray Carrier			
TC1826N Δ	Sheet Pan, Tray Carrier	01, 03	1 ea
Cateraide Insulated End Loaders			
PC300N Δ	End Loader	01, 03, 08, 59, 95	1 ea
PC600N Δ	Double End Loader	01, 03, 08, 59*	1 ea

NSF Listed products are designated with a Δ and may be prefixed with an N

* Color available by special order only

CaterCooler™

- Freeze CaterCooler overnight or for eight hours and it will keep food at or below the ServSafe® guidelines of 40°F for up to eight hours without ice*
- Designed to slide into a CATERaide End Loader, Double End Loader, or place on top of food pans in a Top Loader
- Durable polyethylene shell

ServSafe® is a registered trademark of the National Restaurant Association

*Temperature retention is based on CaterCooler being pre-frozen for a minimum of eight hours, then placed directly into CATERaide pan carrier. Pan Carrier unit is then filled with pre-chilled food pans. Testing was conducted under ambient room temperatures of 76°F.

CaterCooler shown with PC300N End Loader



Dollies - Industry Leader

Polyethylene Dollies

- 4" heavy-duty, quiet, and non-marking swivel casters
- Rolls easily on carpeted floors
- DL300R holds up to two CATERaide End Loaders (PC300N) or any CATERaide Top Loader
- XDL3000 holds up to two Slide 'N Seal End Loaders (XT3000R) when stacked
- NSF Listed



Aluminum Dollies

- Made of sturdy, light-weight, no-rust aluminum
- Plastic coated corner bumpers protect against marring furnishings
- 4" heavy-duty, quiet, and non-marking swivel casters
- Rolls easily on carpeted floors
- DL300 holds up to two stacked CATERaide End Loaders
- DL1826 holds up to three stacked Sheet Pan Carriers



Prod No	Description	Color	Pack
CaterCooler			
PC660	CaterCooler	14	1 ea
Polyethylene CATERaide Dollies			
XDL3000H Δ	22.38" x 28.75" Dolly with Handle	03	1 ea
DL300R Δ	20.38" x 26.75" Dolly	03	1 ea
Aluminum CATERaide Dollies			
DL300	23.25" x 16.88" Dolly	23	1 ea
DL1826	28.63" x 22" Dolly	23	1 ea

NSF Listed products are designated with a Δ and may be prefixed with an N

NOTE: LD500NSS can be shipped UPS/FedEx Ground at oversize cost



CARLISLE
FOODSERVICE PRODUCTS

QUALITY EFFICIENT DURABLE INNOVATIVE **KITCHEN ACCESSORIES**

Designed and used by chefs, Carlisle kitchen accessories are designed to improve food safety and quality, save labor, and reduce waste. You need to operate your kitchen efficiently and effectively every day and you can count on Carlisle to help make work easier.



Items in this section are purchased through Carlisle FoodService Products and will ship separately from Dinex orders. Please contact your local sales representative for more information.



SPARTA® PASTRY & BASTING BRUSHES

Sparta Pastry & Basting Brushes have been the **top choice** of discriminating professional chefs the world over for decades. The **high quality craftsmanship** provides the **best bristle retention in the industry**. You should never sacrifice food safety and with our wide selection of brushes, we have a brush to cover **all of your needs**.

Meteor Pastry/Basting Brushes

- “Molded-into-the-handle” hook hangs on lip of crocks and containers to prevent bristle burn, melt, or distortion
- Use hook to elevate bristles off of counter tops
- Soft flagged bristles are molded into handle to prevent bacteria harboring air pockets
- Available with white nylon bristles or double-boiled, bleached, sterilized, premium boar bristles

Hook hangs on side of crock or elevates bristles off counter tops



Bristles Heat Distortion Point

Synthetic	Up to 350°F (176.7°C)
Boar	500°F (260°C)
Silicone	500°F (260°C)



Prod No	Description	Color	Pack
Sparta Chef Series Pastry Brushes			
40395	1" Wide Brush with Nylon Bristles	—	12 ea
40396	1.5" Wide Brush with Nylon Bristles	—	12 ea
40397	2" Wide Brush with Nylon Bristles	—	12 ea
40398	3" Wide Brush with Nylon Bristles	—	12 ea
40399	4" Wide Brush with Nylon Bristles	—	12 ea
40400	1" Round Brush with Nylon Bristles	—	12 ea
Sparta Meteor Pastry/Basting Brushes			
40378	2" Wide Brush with Boar Bristles	—	12 ea
40379	3" Wide Brush with Boar Bristles	—	12 ea
40401	2" Wide Brush with Nylon Bristles	02, 14	12 ea
40402	3" Wide Brush with Nylon Bristles	02, 14	12 ea

NSF Listed products are designated with a **Δ** and may be prefixed with an N

MEASURERS & SERVING ACCESSORIES

Dishers

- Color-coded for easy identification and portion control
- Smooth operating 18-8 stainless steel construction with ribbed plastic handle
- Bowl capacity is stamped on bail
- Number on bail indicates scoops per quart
- NSF Listed; dishwasher safe

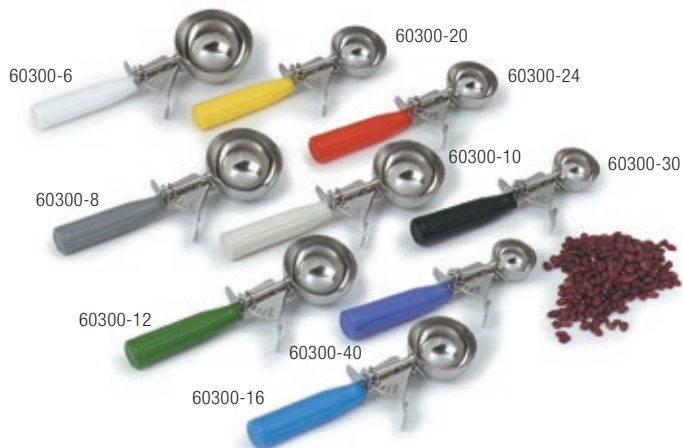

Stainless Steel Measure Misers®

- Portion control spoons in heavy gauge 18-8 stainless steel with durable one-piece construction
- Feature color-coded Kool-Touch handles and built-in pan edge rest
- Dishwasher safe



MeatlineXpress
page 84



DineXpress
page 100



Perfect•Serv Ultra
page 94

Prod No	Description	Pack
Dishers		
60300-6 Δ	4.66 oz Disher with White Handle	12 ea
60300-8 Δ	4 oz Disher with Gray Handle	12 ea
60300-10 Δ	3.75 oz Disher with Ivory Handle	12 ea
60300-12 Δ	3.25 oz Disher with Green Handle	12 ea
60300-16 Δ	2.75 oz Disher with Blue Handle	12 ea
60300-20 Δ	2 oz Disher with Yellow Handle	12 ea
60300-24 Δ	1.75 oz Disher with Red Handle	12 ea
60300-30 Δ	1.25 oz Disher with Black handle	12 ea
60300-40 Δ	.88 oz Disher with Orchid handle	12 ea
Stainless Steel Measure Misers		
604360	2 oz Solid SS Measure Miser, Red	12 ea
604361	2 oz Perforated SS Measure Miser, Red	12 ea
604370	3 oz Solid SS Measure Miser, Beige	12 ea
604371	3 oz Perforated SS Measure Miser, Beige	12 ea
604380	4 oz Solid SS Measure Miser, Green	12 ea
604381	4 oz Perforated SS Measure Miser, Green	12 ea
604390	6 oz Solid SS Measure Miser, Black	12 ea
604392	8 oz Solid SS Measure Miser, Blue	12 ea

NSF Listed products are designated with a Δ and may be prefixed with an N



MEASURERS

Long lasting acetal Color-Coded Measure Misers ensure employees **deliver the consistency** your customers expect without compromising durability.

Color-Coded Measure Misers

- Portion control spoon made of break-resistant acetal material
- Each color represents a different size for easy recognition and consistency
- Spoon's flat bottom easily spreads sauces or toppings
- 4694 features a deep cup style that allows for easier access inside small food pans
- Long handle measure misers have thumb grip for steady control and a notch for resting on pan rim
- Recommended for temperatures up to 212°F
- Withstands dry heat up to 270°F
- BPA Free
- 2-year limited warranty
- NSF Listed; dishwasher safe



MeatlineExpress

page 84



DineExpress

page 100



Perfect•Serv Ultra

page 94

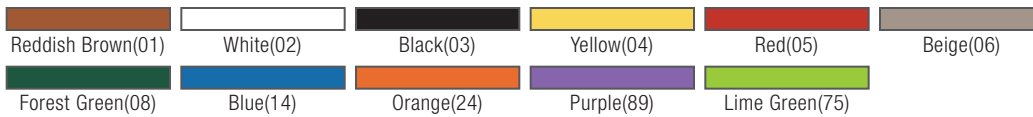

Prod No	Description	Color	Pack
Color-Coded Measure Misers			
Short Handle			
4921 Δ	1 oz, 6.5" Solid Spoon	04, 89	12 ea
4923 Δ	1 oz, 6.5" Perforated Spoon	04	12 ea
4932 Δ	1.25 oz, 7.25" Solid Spoon	75	12 ea
4965 Δ	1.25 oz, 7.25" Perforated Spoon	75	12 ea
4922 Δ	1.5 oz, 7" Solid Spoon	01	12 ea
4961 Δ	1.5 oz, 7" Perforated Spoon	01	12 ea
4924 Δ	2 oz, 7.10" Solid Spoon	05, 89	12 ea
4962 Δ	2 oz, 7.10" Perforated Spoon	05, 89	12 ea
4925 Δ	2.5 oz, 7.10" oz Solid Spoon	24	12 ea
4963 Δ	2.5 oz, 7.10" Perforated Spoon	24	12 ea
4926 Δ	3 oz, 8" Solid Spoon	02, 89	12 ea
4927 Δ	3 oz, 8" Perforated Spoon	02	12 ea
4928 Δ	4 oz, 8.25" Solid Spoon	08, 89	12 ea
4929 Δ	4 oz, 8.25" Perforated Spoon	08	12 ea
4933 Δ	5 oz, 8.62" Solid Spoon	06	12 ea
4966 Δ	5 oz, 8.62" Perforated Spoon	06	12 ea
4930 Δ	6 oz, 8.62" Solid Spoon	03, 89	12 ea
4967 Δ	6 oz, 8.62" Perforated Spoon	03	12 ea
4964 Δ	6 oz, 8.62" Deep Cup Perforated Spoon	03	12 ea
4931 Δ	8 oz, 8.62" Solid Spoon	14	12 ea
4968 Δ	8 oz, 8.62" Perforated Spoon	14	12 ea

Prod No	Description	Color	Pack
Color-Coded Measure Misers			
Long Handle			
3956 Δ	1 oz, 11.5" Solid Spoon	04, 89	12 ea
3957 Δ	1 oz, 11.25" Perforated Spoon	04	12 ea
3958 Δ	1.5 oz, 11.5" Solid Spoon	01	12 ea
3959 Δ	1.5 oz, 11.5" Perforated Spoon	01	12 ea
3960 Δ	2 oz, 11.9" Solid Spoon	05, 89	12 ea
3961 Δ	2 oz, 11.9" Perforated Spoon	05	12 ea
3970 Δ	3 oz, 11.75" Solid Spoon	02	12 ea
3971 Δ	3 oz, 11.75" Perforated Spoon	02	12 ea
3980 Δ	4 oz, 13" Solid Spoon	08, 89	12 ea
3981 Δ	4 oz, 13" Perforated Spoon	08, 89	12 ea
3990 Δ	6 oz, 13.4" Solid Spoon	03	12 ea
3991 Δ	6 oz, 13.4" Perforated Spoon	03	12 ea
3992 Δ	8 oz, 13.25" Solid Spoon	14	12 ea
3993 Δ	8 oz, 13.25" Perforated Spoon	14	12 ea

NSF Listed products are designated with a Δ and may be prefixed with an N

TONGS, WHIPS & TOOLS

Tongs

Heavy-Duty Utility Tongs

- Heavy 20 gauge stainless steel with flat spring for long-lasting service
- Dishwasher safe

Spectrum® Dura-Kool™ Tongs

- Color-coded Dura-Kool handles provide easy visual for zone isolation
- Single-piece, heavy-duty stainless construction eliminates food traps for more sanitary use
- Spring action hinge won't break, also provides convenient hook for storage

Carlisle's Spectrum System supports your HACCP program by promoting zone isolation and reducing the risk of cross-contamination with our complete offering of color-coded kitchen tools and cleaning accessories

Sparta® Chef Series™ French Whips

- Sanitary fully-sealed construction eliminates bacteria harboring food traps
- Rust-free 18-8 stainless construction with heavy gauge spring wire loops
- Perfectly weighted and balanced for heavy mixing, stirring and beating batters, sauces and other thicker mixtures

Commercial Measures

- Made of durable polycarbonate
- Offers easy measuring of wet ingredients
- Available in Cup, Pint, Quart, Half Gallon and Gallon sizes with U.S. and metric measurements
- Oval shape facilitates pouring from non-spouted side
- Family of measurers nest for storage
- NSF Listed; dishwasher safe

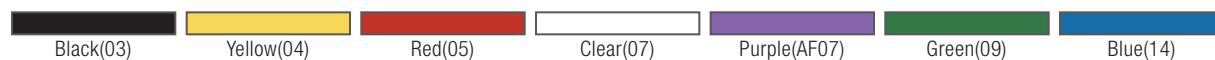

Prod No	Description	Color	Pack
Heavy-Duty Utility Tongs			
607550	9.5" Heavy-Duty Utility Tongs	—	12 ea
607552	12" Heavy-Duty Utility Tongs	—	12 ea
607556	16" Heavy-Duty Utility Tongs	—	12 ea
Spectrum Dura-Kool Tongs			
607560 Δ	9.5" Spectrum Dura-Kool Tong	03, 04, 05, 09, 14	12 ea
607562 Δ	12" Spectrum Dura-Kool Tong	03, 04, 05, 09, 14	12 ea
607566 Δ	16" Spectrum Dura-Kool Tong	03, 05, 09, 14	12 ea
Sparta Chef Series French Whips			
40681	36" Chef Series Heavy-Weight French Whip	—	2 ea
40682	48" Chef Series Heavy-Weight French Whip	—	2 ea
Commercial Measures			
43141 Δ ♦	Cup Size PC Measure	07, AF07	12 ea
43142 Δ ♦	Pint Size PC Measure	07, AF07	6 ea
43143 Δ ♦	Quart Size PC Measure	07, AF07	6 ea
43144 Δ ♦	Half Gallon Size PC Measure	07, AF07	6 ea
43145 Δ ♦	Gallon Size PC Measure	07, AF07	6 ea

NSF Listed products are designated with a Δ and may be prefixed with an N
 ♦ California Residents: Bisphenol A **WARNING:** See appendix A on page 281



CARLISLE
FOODSERVICE PRODUCTS

20L — 22 qt.
20L — 20 qt.
15L — 16 qt.
10L — 12 qt.
10L — 10 qt.
8 qt.

TOUGH VERSATILE SAFE INNOVATIVE **STORAGE & HANDLING SUPPLIES**

From distinct color-coding to easy-clean surfaces, Carlisle ensures that all of our products are designed to safely store, handle and transport food. You can count on Carlisle to help you keep food fresh, reduce food safety risks, reduce waste, and operate efficiently



Items in this section are purchased through Carlisle FoodService Products and will ship separately from Dinex orders. Please contact your local sales representative for more information.



STORPLUS™ FOOD PANS

StorPlus is perfect for holding food day after day in all cold applications including buffets, cold wells, service line applications and fridge/freezer storage.

Food Pans

- Smooth interior makes clean-up easy
- Reinforced corners prevent chips and cracks, stand up to drops and use day after day
- Universally stackable with all food pan products on the market
- Spoonable bottoms allow easy removal of contents and reduction of food waste
- Polycarbonate containers can withstand temperatures from -40°F to 212°F
- High-heat pans excel in high temperature applications and are BPA Free (-40°F to 375°F)
- Compatible with Carlisle StorPlus Universal Lids, Smart Lids, Drain Grates and EZ Access Lids
- Textured non-slip finish on corners, sides, bottom and lid reduce scratches
- Molded-in capacity indicators are listed in both quarts and liters
- NSF Certified; Made in the USA; Dishwasher Safe



EZ Access Lids

- 50% to 60% larger opening improves hand and utensil access; reduces food waste
- Snug lid stays in place during routine opening; never flips off
- Clean design eliminates dangerous food traps found on other hinged lid designs
- The perfect solution for salad, cucumbers, buffets, prep stations and more
- Compliments Coldmaster and CoolCheck pans
- One-half and one-third sizes available with double notch for multiple portioning options
- Double-hinged design handles the abuse of the most demanding foodservice applications
- Convenient molded-in peg hole
- NSF Listed; dishwasher safe



Universal Food Pan Lids

- Fit Carlisle StorPlus Food Pans as well as other major brands on the market
- Features a hanging hole for easy storage
- Fits both Gastronorm and standard size food pans
- Carlisle lids stack with themselves for easy storage
- Available in polycarbonate or high heat material
- NSF Listed; dishwasher safe





Smart Lids™

- Unique inside seal design provides superior leak-resistance and keeps your foods fresher, longer
- Perfect for transporting foods to off site locations
- Smart Lids (combined with StorPlus Food Pans) fit inside Cateraide Top Loaders and End Loaders (shown on pages 185-186)
- Polyethylene material is dishwasher safe; for use in -40°F to 180°F
- Designed exclusively to fit StorPlus Food Pans



Smart Lid's unique inside seal design provides superior leak-resistance; protects against spills

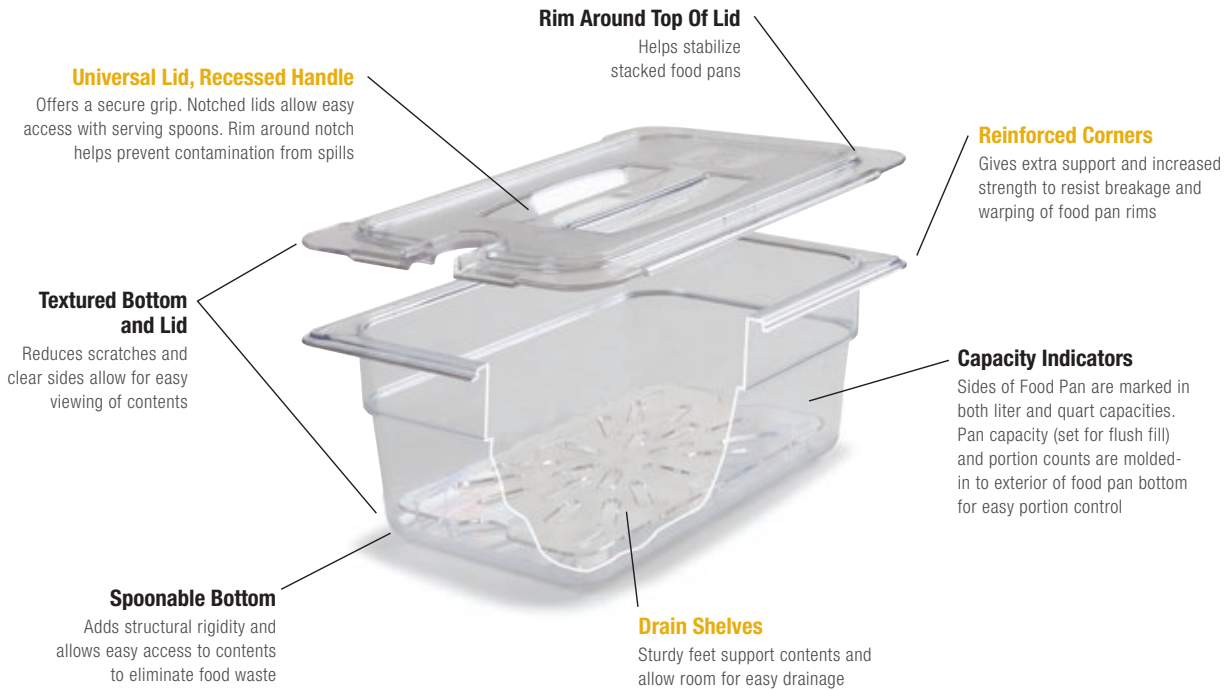

Suggested Pan Layouts

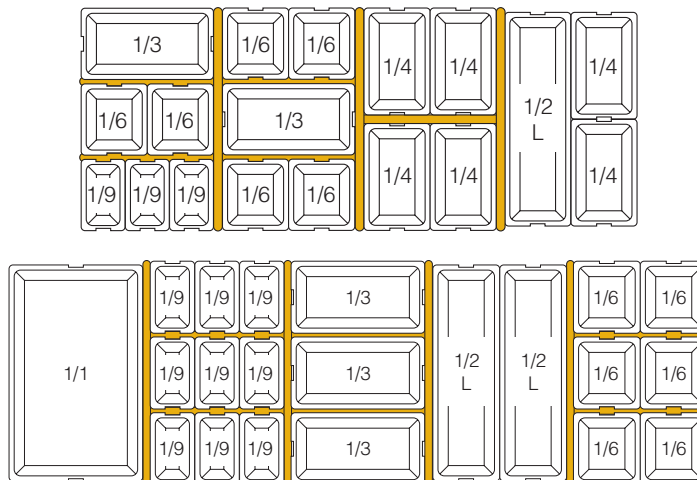



STORPLUS™ FOOD PANS AND LIDS

Polycarbonate Food Pans & Lids

- Smooth interior makes clean-up easy.
- Reinforced corners prevent chips and cracks, stand up to drops and use day after day
- Universally stackable with all food pan products on the market
- Spoonable bottoms allow easy removal of contents and reduction of food waste
- Polycarbonate containers can withstand temperatures from -40°F to 212°F
- Compatible with Carlisle StorPlus Universal Lids, Smart Lids, Drain Grates and EZ Access Lids
- Textured non-slip finish on corners, sides, bottom and lid reduce scratches
- Molded-in capacity indicators are listed in both quarts and liters
- NSF Certified; Made in the USA; Dishwasher Safe

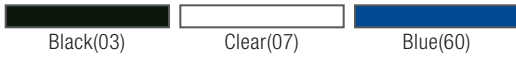

Prod No	Description	Color	Pack
Full-Size – 20.75" x 12.75"			
10200B ▲	Pan – 2.5" (7.6 qt)	03, 07	6 ea
10201B ▲	Pan – 4" (12.7 qt)	03, 07	6 ea
10202B ▲	Pan – 6" (19.4 qt)	03, 07	6 ea
10203B ▲	Pan – 8" (25.9 qt)	03, 07	6 ea
10215 ▲	Drain Shelf	07	6 ea
Lids – Fits All Full-Size Pans			
10212B	Smart Lid, Unnotched	60	6 ea
10210U ▲	Handled Lid, Unnotched	07	6 ea
10211U ▲	Handled Lid, Single Notched	07	6 ea
10216U ▲	Flat Lid, Unnotched	07	6 ea
10217U ▲	Flat Lid, Single Notched	07	6 ea
One-Half Size – 12.75" x 10.38"			
10220B ▲	Pan – 2.5" (3.6 qt)	03, 07	6 ea
10221B ▲	Pan – 4" (5.6 qt)	03, 07	6 ea
10222B* ▲	Pan – 6" (8.7 qt)	03, 07	6 ea
10223B ▲	Pan – 8" (11.4 qt)	07	6 ea
10235 ▲	Drain Shelf	07	6 ea

Prod No	Description	Color	Pack
EZ Access Lids – One Half Size			
10238Z ▲	Handled Lid, Unnotched	07	6 ea
10239Z ▲	Handled Lid, Single Notched	07	6 ea
10240Z ▲	Handled Lid, Double Notched	07	6 ea
Lids – Fits All One-Half Size Pans			
10232B	Smart Lid, Unnotched	60	6 ea
10230U ▲	Handled Lid, Unnotched	07	6 ea
10231U ▲	Handled Lid, Single Notched	07	6 ea
10236U ▲	Flat Lid, Unnotched	07	6 ea
One-Half Long Size – 20.75" x 6.25"			
10240B ▲	Pan – 2.5" (2.9 qt)	03, 07	6 ea
10241B ▲	Pan – 4" (5.1 qt)	03, 07	6 ea
Lids – Fits All One-Half Long Size Pans			
10250U ▲	Handled Lid, Unnotched	07	6 ea
10256U ▲	Flat Lid, Unnotched	07	6 ea

NSF Listed products are designated with a ▲ and may be prefixed with an N
 ▲ California Residents: Bisphenol A **WARNING:** See appendix A on page 281

EZ Access Lids

- 50% to 60% larger opening improves hand and utensil access; reduces foodwaste
- Snug lid stays in place during routine opening; never flips off
- Clean design eliminates dangerous food traps found on other hinged lid designs
- The perfect solution for salad, cucumbers, buffets, prep stations and more
- Compliment your Coldmaster and CoolCheck pans
- One-half and one-third sizes available with double notch for multiple portioning options
- Double-hinged design handles the abuse of the most demanding foodservice applications
- Convenient molded-in peg hole
- NSF Listed; dishwasher safe



Prod No	Description	Color	Pack
<div style="display: flex; justify-content: space-around; border-bottom: 1px solid black; margin-bottom: 5px;"> Black(03) Clear(07) Blue(60) </div>			
One-Third Size – 12.75" x 7"			
30660 Δ \blacklozenge	Pan – 2.5" (2.4 qt)	03, 07	6 ea
30661 Δ \blacklozenge	Pan – 4" (3.8 qt)	03, 07	6 ea
30662 Δ \blacklozenge	Pan – 6" (5.7 qt)	03, 07	6 ea
30669 Δ \blacklozenge	Pan – 8" (7.3 qt)	03, 07	6 ea
30670 Δ \blacklozenge	Drain Shelf	07	6 ea
EZ Access Lids – One Third Size			
10278Z Δ \blacklozenge	Handled Lid, Unnotched	07	6 ea
10279Z Δ \blacklozenge	Handled Lid, Single Notched	07	6 ea
10280Z Δ \blacklozenge	Handled Lid, Double Notched	07	6 ea
Lids – Fits All One-Third Size Pans			
30580	Smart Lid, Unnotched	60	6 ea
10270U Δ \blacklozenge	Handled Lid, Unnotched	07	6 ea
10271U Δ \blacklozenge	Handled Lid, Single Notched	07	6 ea
10276U Δ \blacklozenge	Flat Lid, Unnotched	07	6 ea
10277U Δ \blacklozenge	Flat Lid, Single Notched	07	6 ea
One-Quarter Size – 10.25" x 6.38"			
30680 Δ \blacklozenge	Pan – 2.5" (1.7 qt)	03, 07	6 ea
30681 Δ \blacklozenge	Pan – 4" (2.8 qt)	03, 07	6 ea
30682 Δ \blacklozenge	Pan – 6" (4.0 qt)	03, 07	6 ea
30695 Δ \blacklozenge	Drain Shelf	07	6 ea
Lids – Fits All One-Quarter Size Pans			
30581	Smart Lid, Unnotched	60	6 ea
10290U Δ \blacklozenge	Handled Lid, Unnotched	07	6 ea
10291U Δ \blacklozenge	Handled Lid, Single Notched	07	6 ea
10296U Δ \blacklozenge	Flat Lid, Unnotched	07	6 ea
10297U Δ \blacklozenge	Flat Lid, Single Notched	07	6 ea

Prod No	Description	Color	Pack
One-Sixth Size – 6.75" x 6.38"			
30683 Δ \blacklozenge	Pan – 2.5" (1.1 qt)	03, 07	6 ea
30684 Δ \blacklozenge	Pan – 4" (1.7 qt)	03, 07	6 ea
30685 Δ \blacklozenge	Pan – 6" (2.5 qt)	03, 07	6 ea
30689 Δ \blacklozenge	Drain Shelf	07	6 ea
EZ Access Lids – One Sixth Size			
10318Z Δ \blacklozenge	Handled Lid, Unnotched	07	6 ea
10319Z Δ \blacklozenge	Handled Lid, Single Notched	07	6 ea
Lids – Fits All One-Sixth Size Pans			
30582	Smart Lid, Unnotched	60	6 ea
10310U Δ \blacklozenge	Handled Lid, Unnotched	07	6 ea
10311U Δ \blacklozenge	Handled Notched Lid	07	6 ea
10316U Δ \blacklozenge	Flat Lid, Unnotched	07	6 ea
10317U Δ \blacklozenge	Flat Lid, Single Notched	07	6 ea
One-Ninth Size – 6.75" x 4.25"			
30686 Δ \blacklozenge	Pan – 2.5" (0.7 qt)	03, 07	6 ea
30687 Δ \blacklozenge	Pan – 4" (1.0 qt)	03, 07	6 ea
30688 Δ \blacklozenge	Pan – 6" (1.4 qt)	03, 07	6 ea
10335 Δ \blacklozenge	Drain Shelf	07	6 ea
EZ Access Lids – One Ninth Size			
10338Z Δ \blacklozenge	Handled Lid, Unnotched	07	6 ea
10339Z Δ \blacklozenge	Handled Lid, Single Notched	07	6 ea
Lids – Fits All One-Ninth Size Pans			
30583	Smart Lid, Unnotched	60	6 ea
10336U Δ \blacklozenge	Flat Lid, Unnotched	07	6 ea
10337U Δ \blacklozenge	Flat Lid, Single Notched	07	6 ea

NSF Listed products are designated with a Δ and may be prefixed with an N
 \blacklozenge California Residents: Bisphenol A **WARNING:** See appendix A on page 281



High Heat Food Pans & Lids

- High heat pans excel in high temperature applications (-40°F to 375°F)
- For a leak-resistant seal use Smart Lids



Black(03)	Amber(13)	Blue(60)
-----------	-----------	----------

Prod No	Description	Color	Pack
Full-Size – 20.75" x 12.75"			
10400B Δ	Pan – 2.5" (7.6 qt)	03, 13	6 ea
10401B Δ	Pan – 4" (12.7 qt)	03, 13	6 ea
10402B Δ	Pan – 6" (19.4 qt)	03, 13	6 ea
10415 Δ	Drain Shelf	13	6 ea
Lids – Fits All Full-Size Pans			
10212B	Smart Lid, Unnotched	60	6 ea
10410U Δ	Handled Lid, Unnotched	13	6 ea
10411U Δ	Handled Lid, Single Notched	13	6 ea
10416U Δ	Flat Lid, Unnotched	13	6 ea
10417U Δ	Flat Notched Lid	13	6 ea
One-Half Size – 12.75" x 10.38"			
10420B Δ	Pan – 2.5" (3.6 qt)	03, 13	6 ea
10421B Δ	Pan – 4" (5.6 qt)	03, 13	6 ea
10422B Δ	Pan – 6" (8.7 qt)	03, 13	6 ea
10423B Δ	Pan – 8" (11.4 qt)	03, 13	6 ea
10435 Δ	Drain Shelf	13	6 ea
EZ Access Lids – One Half Size			
10438Z Δ	EZ Access Lid, Unnotched	13	6 ea
10439Z Δ	EZ Access Lid, Single Notched	13	6 ea
10440Z	EZ Access Lid, Double Notched	13	6 ea
Lids – Fits All One-Half Size Pans			
10232B	Smart Lid, Unnotched	60	6 ea
10430U Δ	Handled Lid, Unnotched	13	6 ea
10431U Δ	Handled Lid, Single Notched	13	6 ea
10436U Δ	Flat Lid, Unnotched	13	6 ea
10437U Δ	Flat Lid, Single Notched	13	6 ea
One-Half Long Size – 20.75" x 6.25"			
10440B Δ	Pan – 2.5" (2.9 qt)	03, 13	6 ea
10441B Δ	Pan – 4" (5.1 qt)	03, 13*	6 ea
Lids – Fits All One-Half Long Size Pans			
10450U Δ	Handled Lid, Unnotched	13	6 ea
One-Third Size – 12.75" x 7"			
30860 Δ	Pan – 2.5" (2.4 qt)	03, 13	6 ea
30861 Δ	Pan – 4" (3.8 qt)	03, 13	6 ea
30862 Δ	Pan – 6" (5.7 qt)	03, 13	6 ea
30869 Δ	Pan – 8" (7.3 qt)	03, 13	6 ea
30870 Δ	Drain Shelf	13	6 ea
EZ Access Lids – One Third Size			
10478Z Δ	EZ Access Lid, Unnotched	13	6 ea
10479Z Δ	EZ Access Lid, Single Notched	13	6 ea
10480Z Δ	EZ Access Lid, Double Notched	13	6 ea

Prod No	Description	Color	Pack
Lids – Fits All One-Third Size Pans			
30580	Smart Lid, Unnotched	60	6 ea
10470U Δ	Handled Lid, Unnotched	13	6 ea
10471U Δ	Handled Lid, Single Notched	13	6 ea
10476U Δ	Flat Lid, Unnotched	13	6 ea
10477U Δ	Flat Lid, Single Notched	13	6 ea
One-Quarter Size – 10.25" x 6.38"			
30880 Δ	Pan – 2.5" (1.7 qt)	03, 13	6 ea
30881 Δ	Pan – 4" (2.8 qt)	03, 13	6 ea
30882 Δ	Pan – 6" (4.0 qt)	03, 13	6 ea
30895 Δ	Drain Shelf	13	6 ea
Lids – Fits All One-Quarter Size Pans			
30581	Smart Lid, Unnotched	60	6 ea
10490U Δ	Handled Lid, Unnotched	13	6 ea
10491U Δ	Handled Lid, Single Notched	13	6 ea
10496U Δ	Flat Lid, Unnotched	13	6 ea
One-Sixth Size – 6.75" x 6.38"			
30883 Δ	Pan – 2.5" (1.1 qt)	03, 13	6 ea
30884 Δ	Pan – 4" (1.7 qt)	03, 13	6 ea
30885 Δ	Pan – 6" (2.5 qt)	03, 13	6 ea
30896 Δ	Drain Shelf	13	6 ea
EZ Access Lids – One Half Size			
10518Z Δ	EZ Access Lid, Unnotched	13	6 ea
10519Z Δ	EZ Access Lid Notched	13	6 ea
Lids – Fits All One-Sixth Size Pans			
30582	Smart Lid, Unnotched	60	6 ea
10510U Δ	Handled Lid, Unnotched	13	6 ea
10511U Δ	Handled Lid, Single Notched	13	6 ea
10516U Δ	Flat Lid, Unnotched	13	6 ea
One-Ninth Size – 6.75" x 4.25"			
30886 Δ	Pan – 2.5" (0.7 qt)	03, 13	6 ea
30887 Δ	Pan – 4" (1.0 qt)	03, 13	6 ea
30888 Δ	Pan – 6" (1.4 qt)	03, 13	6 ea
10535 Δ	Drain Shelf	13	6 ea
EZ Access Lids – One Ninth Size			
10538Z Δ	EZ Access Lid, Unnotched	13	6 ea
10539Z Δ	EZ Access Lid, Single Notched	13	6 ea
Lids – Fits All One-Ninth Size Pans			
30583	Smart Lid, Unnotched	60	6 ea
10536U Δ	Flat Lid, Unnotched	13	6 ea
10537U Δ	Flat Lid, Single Notched	13	6 ea

NSF Listed products are designated with a Δ and may be prefixed with an N
 Note: Capacities are based on liquid measurements to rim, i.e. flush fill

METAL FOOD PANS & LIDS

Food pans are **the back bone of any foodservice operation**. For storing, preparing and serving, they are a necessity. Only Carlisle offers you **complete versatility with a broad range of food pans** to meet your needs.



DuraPan™ Food Pans

Double reinforced corners and unique impact resistant edge design help pans hold shape; will not jam together during storage. Tapered pans fit standard food pan templates and will stack or nest with most other leading brands. Versatile 18-8 stainless pans go from freezer to oven to serving line; ideal for cook-chill operations.

Steam Table Application

DuraPan's impact resistant edge maintains shape better and lays flat, providing a tight seal for better temperature retention in steam tables



Coldmaster® Application

Use DuraPans with Coldmaster Coldpans (shown on page 201-202) to keep foods cold without ice or electricity

DuraPan Covers

- Made of heavy gauge 18-8 stainless steel
- Available in solid or slotted styles
- Recessed handles offer a secure grip
- Notched lids allow easy access for serving spoons



Adapter Bars

- Use adapter bars with in steam table applications, Cateraides, or other standard transport containers
- Two sizes available to work with full or fractional size pans

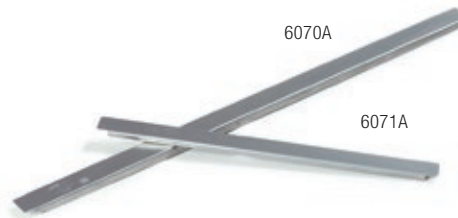

Prod No	Description	Pack
Adapter Bars		
6070A Δ	20.5" Adapter Bar	12 ea
6071A Δ	12.75" Adapter Bar	12 ea

NSF Listed products are designated with a Δ and may be prefixed with an N



Available in heavy gauge or light gauge, Carlisle offers a wide range of accessories including solid and slotted covers, drain shelves, divided pans, and adapter bars.

Prod No	Description	Pack
Heavy Gauge		
Full-Size – 20.75" x 12.75"		
608002 Δ	Pan – 2.5" (10.4 qt)	6 ea
608004 Δ	Pan – 4" (16.6 qt)	6 ea
608006 Δ	Pan – 6" (24.9 qt)	6 ea
Two-Thirds Size – 13.88" x 12.75"		
608236 Δ	Pan – 6" (16.2 qt)	6 ea
One-Half Size – 12.75" x 10.38"		
608122 Δ	Pan – 2.5" (0.9 qt)	6 ea
608124 Δ	Pan – 4" (1.4 qt)	6 ea
608126 Δ	Pan – 6" (2.1 qt)	6 ea
One-Third Size – 12.75" x 6.88"		
608132 Δ	Pan – 2.5" (3.4 qt)	6 ea
608134 Δ	Pan – 4" (5.4 qt)	6 ea
608136 Δ	Pan – 6" (8.1 qt)	6 ea
One-Quarter Size – 10.38" x 6.38"		
608142 Δ	Pan – 2.5" (2.6 qt)	6 ea
608144 Δ	Pan – 4" (4.2 qt)	6 ea
608146 Δ	Pan – 6" (6.2 qt)	6 ea
One-Sixth Size – 6.88" x 6.25"		
608162 Δ	Pan – 2.5" (1.6 qt)	6 ea
608164 Δ	Pan – 4" (2.6 qt)	6 ea
608166 Δ	Pan – 6" (3.9 qt)	6 ea
One-Ninth Size – 6.88" x 4.25"		
608192 Δ	Pan – 2.5" (1.0 qt)	6 ea
608194 Δ	Pan – 4" (1.7 qt)	6 ea



Mealtimexpress
page 84



DineXpress
page 100



Perfect•Serv Ultra
page 94

Prod No	Description	Pack
Light Gauge		
Full-Size – 20.75" x 12.75"		
607001 Δ	Pan – 1" (4.2 qt)	6 ea
607002 Δ	Pan – 2.5" (10.4 qt)	6 ea
607004 Δ	Pan – 4" (16.6 qt)	6 ea
607006 Δ	Pan – 6" (24.9 qt)	6 ea
607002P Δ	Perforated Pan – 2.5"	6 ea
607004P Δ	Perforated Pan – 4"	6 ea
607006P Δ	Perforated Pan – 6"	6 ea
607000C Δ	Solid Cover	6 ea
607000CS	Slotted Cover	6 ea
607000H	Hinged Flat Cover with Handles	6 ea
Two-Thirds Size – 13.88" x 12.75"		
607232 Δ	Pan – 2.5" (6.8 qt)	6 ea
607236 Δ	Pan – 6" (16.2 qt)	6 ea
607230C Δ	Solid Cover	6 ea
One-Half Size – 12.75" x 10.38"		
607122 Δ	Pan – 2.5" (0.9 qt)	6 ea
607124 Δ	Pan – 4" (1.4 qt)	6 ea
607126 Δ	Pan – 6" (2.1 qt)	6 ea
607122P Δ	Perforated Pan – 2.5"	6 ea
607124P Δ	Perforated Pan – 4"	6 ea
607120C Δ	Solid Cover	6 ea
607120CS	Slotted Cover	6 ea
One-Half Long Size – 20.5" x 6.38"		
60700HL2 Δ	Pan – 2.5" (5.2 qt)	6 ea
60700HL4 Δ	Pan – 4" (8.3 qt)	6 ea
60700HL6 Δ	Pan – 6" (12.5 qt)	6 ea
60700HLC Δ	Solid Cover	6 ea
One-Third Size – 12.75" x 6.88"		
607132 Δ	Pan – 2.5" (3.4 qt)	6 ea
607134 Δ	Pan – 4" (5.4 qt)	6 ea
607136 Δ	Pan – 6" (8.1 qt)	6 ea
607130C Δ	Solid Cover	6 ea
607130CS	Slotted Cover	6 ea
One-Quarter Size – 10.38" x 6.38"		
607142 Δ	Pan – 2.5" (2.6 qt)	6 ea
607144 Δ	Pan – 4" (4.2 qt)	6 ea
607146 Δ	Pan – 6" (6.2 qt)	6 ea
607140C Δ	Solid Cover	6 ea
607140CS	Slotted Cover	6 ea
One-Sixth Size – 6.88" x 6.25"		
607162 Δ	Pan – 2.5" (1.6 qt)	6 ea
607164 Δ	Pan – 4" (2.6 qt)	6 ea
607166 Δ	Pan – 6" (3.9 qt)	6 ea
607160C Δ	Solid Cover	6 ea
607160CS	Slotted Cover	6 ea
One-Ninth Size – 6.88" x 4.25"		
607192 Δ	Pan – 2.5" (1.0 qt)	6 ea
607194 Δ	Pan – 4" (1.7 qt)	6 ea
607190C Δ	Solid Cover	6 ea
607190CS	Slotted Cover	6 ea

NSF Listed products are designated with a Δ and may be prefixed with an N
Note: Capacities are based on liquid measurements to rim, i.e. flush fill

STORPLUS™ STORAGE CONTAINERS

StorPlus storage containers are clear and have **tight fitting lids**, improving organization and **minimizing the risk** of cross contamination, **making work easier**.

Safe & Easy Lifting
 Carlisle offers square storage containers in 2qt to 22qt with handles on both sides

Square Food Storage Containers

- Perfect for storing condiments, spices, toppings, leftover or preparation
- Stacking lugs add rigidity and eliminate jamming
- Stackable with other popular brands; compatible lids fit competitors' food storage containers
- Wide handles and drain holes available on all sizes for easy-grip and quick drying
- Writing surface available to record dates and reduce food waste
- Color-coded, textured snap-on lids fit both the polycarbonate and polyethylene containers
- Smooth interior finish with spoonable bottom helps prevent food waste and makes clean-up easy

- Clear polycarbonate containers provide exceptional durability and can withstand temperatures from -40°F to 212°F
- Economical white polyethylene containers withstand temperatures from -40°F to 180°F
- NSF Listed; dishwasher safe



Prod No	Description	Color	Pack
StorPlus Square Polycarbonate Food Storage Containers			
10720 Δ ♦	2 qt, 7.13" Sq x 3.81" H Polycarbonate Container	07, AF07	6 ea
10721 Δ ♦	4 qt, 7.13" Sq x 7.31" H Polycarbonate Container	07, AF07	6 ea
10722 Δ ♦	6 qt, 8.75" Sq x 7.31" H Polycarbonate Container	07, AF07	6 ea
10723 Δ ♦	8 qt, 8.75" Sq x 9" H Polycarbonate Container	07, AF07	6 ea
10724 Δ ♦	12 qt, 11.13" Sq x 8.25" H Polycarbonate Container	07, AF07	6 ea
10725 Δ ♦	18 qt, 11.13" Sq x 12.56" H Polycarbonate Container	07, AF07	6 ea
10726 Δ ♦	22 qt, 11.13" Sq x 15.75" H Polycarbonate Container	07, AF07	6 ea
StorPlus Square Polyethylene Food Storage Containers			
10730 Δ	2 qt, 7.13" Sq x 3.81" H Polyethylene Container	02	6 ea
10731 Δ	4 qt, 7.13" Sq x 7.31" H Polyethylene Container	02	6 ea
10732 Δ	6 qt, 8.75" Sq x 7.31" H Polyethylene Container	02	6 ea
10733 Δ	8 qt, 8.75" Sq x 9" H Polyethylene Container	02	6 ea
10734 Δ	12 qt, 11.13" Sq x 8.25" H Polyethylene Container	02	6 ea
10735 Δ	18 qt, 11.13" Sq x 12.56" H Polyethylene Container	02	6 ea
10736 Δ	22 qt, 11.13" Sq x 15.75" H Polyethylene Container	02	6 ea
StorPlus Square Container Lids			
10740 Δ	2-4 qt, 7.31" Sq Lid	08, 89	6 ea
10741 Δ	6-8 qt, 9" Sq Lid	05, 89	6 ea
10742 Δ	12-18-22 qt, 11.38" Sq Lid	60, 89	6 ea

NSF Listed products are designated with a Δ and may be prefixed with an N
 Note: Capacities are based on liquid measurements to rim, i.e. flush fill



STORPLUS™ STORAGE BOXES

StorPlus **color-coded** storage boxes are a solution that helps employees **easily identify** proper storage containers, **eliminating cross-contamination**.

StorPlus Color-Coded Storage Boxes & Lids

Food Storage Boxes

- Reinforced top and bottom corners on both box and lid, help prevent chipping and cracking
- Quart, gallon and liter capacity indicators (on 12" x 18" box)
- StorPlus boxes stack easily for efficient storage, fit standard carts and racks and with other boxes on the market
- Smooth interior surface makes cleaning easy
- "Lock-Tight" lids can be reversed and used as bun pan or tray
- Polycarbonate boxes provide easy visibility, superior resistance to food acids and oils and withstands temperatures from -40°F to 212°F
- Boxes double as dough proofing bus boxes, warewashing tubs for kitchen overflow or remote locations
- 18" x 26" colander is ideal for storing, draining, thawing and marinating foods; keeps lettuce crisp, thaws and drains fish on ice, marinates chicken, etc.
- Polyethylene boxes offers economical storage and transport and withstands temperatures from -40°F to 180°F
- NSF Listed; dishwasher safe



Benefits of StorPlus Color-Coded Storage Boxes

- Prevent cross-contamination and help meet standards as part of a complete HACCP Program
- RimGlow™ technology gives the boxes and lids a distinct, yet transparent color to segregate them by usage

ServSafe® Recommended Stacking Order:



Allergen Control

Cooked/Dry Foods and Dairy

Fruits/Vegetables

Meats

Fish/Seafood

Poultry

ServSafe® is a registered trademark of the National Restaurant Association

White(02)	Red(05)	Clear(07)	Green(09)	Blue(14)	Yellow(22)	Purple(89)
Prod No	Color	Prod No	Color	Description	Pack	
Clear Polycarbonate*		Color-Coded Polycarbonate				
10610 Δ ♦	07			2 gal 12" x 18" x 3.5 Box	6 ea	
10611 Δ ♦	07	10611C Δ ♦	05, 09, 14, 22	3.5 gal 12" x 18" x 6" Box	6 ea	
10612 Δ ♦	07	10612C Δ ♦	05, 09, 14, 22	5 gal 12" x 18" x 9" Box	6 ea	
10617 Δ ♦	07	10617C Δ ♦	05, 09, 14, 22	12" x 18" Lid	6 ea	
10620 Δ ♦	07	—		5 gal 18" x 26" x 3.5" Box	6 ea	
10621 Δ ♦	07	10621C Δ ♦	05, 09, 14, 22, 89	8.5 gal 18" x 26" x 6" Box	6 ea	
10622 Δ ♦	07	10622C Δ ♦	05, 09, 14, 22, 89	12.5 gal 18" x 26" x 9" Box	4 ea	
10623 Δ ♦	07	10623C Δ ♦	05, 09, 14, 22	16.6 gal 18" x 26" x 12" Box	3 ea	
10624 Δ ♦	07	10624C Δ ♦	05, 09, 14, 22	21.5 gal 18" x 26" x 15" Box	3 ea	
10627 Δ ♦	07	10627C Δ ♦	05, 09, 14, 22, 89	18" x 26" Lid	6 ea	
10628 Δ ♦	07	—		18" x 26" x 5" Colander	6 ea	
10629 Δ ♦	07	—		18" x 26" Drain Grate	6 ea	

NSF Listed products are designated with a Δ and may be prefixed with an N

Clear polycarbonate food boxes comes in Clear(07) only

♦ California Residents: Bisphenol A **WARNING:** See appendix A on page 281



White(02)

Prod No	Description	Color	Pack
White Polyethylene			
10630 Δ	2 gal 12" x 18" x 3.5" Box	02	6 ea
10631 Δ	3.5 gal 12" x 18" x 6" Box	02	6 ea
10632 Δ	5 gal 12" x 18" x 9" Box	02	6 ea
10637 Δ	12" x 18" "Lock-Tight" Lid	02	6 ea
10640 Δ	5 gal 18" x 26" x 3.5" Box	02	6 ea
10641 Δ	8.5 gal 18" x 26" x 6" Box	02	6 ea
10642 Δ	12.5 gal 18" x 26" x 9" Box	02	4 ea
10643 Δ	16.6 gal 18" x 26" x 12" Box	02	3 ea
10644 Δ	21.5 gal 18" x 26" x 15" Box	02	3 ea
10647 Δ	18" x 26" "Lock-Tight" Lid	02	6 ea
10648 Δ	18" x 26" x 5" Colander	02	6 ea

NSF Listed products are designated with a Δ and may be prefixed with an N



STORPLUS™ STORAGE CONTAINERS

Round Food Storage Containers

- Super-tough, clear polycarbonate for ultimate durability allows easy food content identification at a glance
- StorPlus containers stack with other major brands for convenient storage; stacking shoulder prevents jamming
- Date indicator helps maintain food quality and control inventory turns, interchangeable with other brands
- Exclusive Carlisle spoonable bottom for increased yield and less food waste
- Clear polycarbonate containers can withstand temperatures from -40°F to 212°F
- NSF Listed; dishwasher safe



Prod No	Description	Color	Pack
StorPlus Round Food Storage Containers			
10761 Δ ♦	1 qt Round Container	07	12 ea
10763 Δ ♦	2 qt Round Container	07	12 ea
10764 Δ ♦	4 qt Round Container	07	12 ea
10765 Δ ♦	6 qt Round Container	07	12 ea
10766 Δ ♦	8 qt Round Container	07	12 ea
10767 Δ ♦	12 qt Round Container	07	6 ea
10768 Δ ♦	18 qt Round Container	07	6 ea
10769 Δ ♦	22 qt Round Container	07	6 ea
StorPlus Round Container Lids			
10770 Δ ♦	1 qt Round Lid	30	12 ea
10771 Δ ♦	2-4 qt Round Lid	08	12 ea
10772 Δ ♦	6-8 qt Round Lid	05	12 ea
10773 Δ ♦	12-18-22 qt Round Lid	60	6 ea

NSF Listed products are designated with a Δ and may be prefixed with an N
 ♦ California Residents: Bisphenol A **WARNING:** See appendix A on page 281



Bains Marie

- Carlisle Bains Marie are the original round food storage containers
- Outside stacking lugs prevent jamming
- 12, 18, & 22 qt sizes have recessed handles for extra strength and stability in lifting, as well as graduated U.S. measurements shown on the side of the container
- 2, 3.5, 6, & 8 qt sizes can be imprinted
- Clear polypropylene containers are translucent and seamless, offering contact clarity for easy identification of products
- Polypropylene containers withstand temperatures from 32°F to 170°F
- Economical white polyethylene containers will withstand temperatures from -40°F to 180°F
- NSF Listed; dishwasher safe



White(02)	Translucent(30)
-----------	-----------------

Prod No	Description	Color	Pack
Bains Marie Polypropylene Containers			
0205 Δ	2 qt Container, 6.56" D x 4.38" H	30	12 ea
0355 Δ	3.5 qt Container, 6.56" D x 7.63" H	30	12 ea
0605 Δ	6 qt Container, 7.63" D x 8.13" H	30	12 ea
0805 Δ	8 qt Container, 7.63" D x 10.75" H	30	12 ea
1205 Δ	12 qt Container, 12.25" D x 8.75" H	30	6 ea
1805 Δ	18 qt Container, 12.38" D x 13" H	30	6 ea
2205 Δ	22 qt Container, 12.25" D x 15.44" H	30	6 ea
Bains Marie Polypropylene Container Lids			
0202 Δ	2 – 3.5 qt Lid, 6.69" D x .31" H	30	12 ea
0602 Δ	6 – 8 qt Lid, 8.06" D x .38" H	30	12 ea
1252 Δ	12 – 18 – 22 qt Lid, 12.38" D x .75" H	30	6 ea
Bains Marie Polyethylene Containers			
0200 Δ	2 qt Container, 6.56" D x 4.44" H	02	12 ea
0350 Δ	3.5 qt Container, 6.56" D x 7.63" H	02	12 ea
0600 Δ	6 qt Container, 7.63" D x 8.13" H	02	12 ea
0800 Δ	8 qt Container, 7.625" D x 10.75" H	02	12 ea
1200 Δ	12 qt Container, 12.25" D x 8.75" H	02	6 ea
1800 Δ	18 qt Container, 12.38" D x 13" H	02	6 ea
2200 Δ	22 qt Container, 12.25" D x 15.44" H	02	6 ea
Bains Marie Polyethylene Container Lids			
0203 Δ	2 – 3.5 qt Lid, 6.69" D	02	12 ea
0603 Δ	6 – 8 qt Lid, 8.63" D	02	12 ea
1202 Δ	12 – 18 – 22 qt Lid, 12.38" D	02	6 ea

NSF Listed products are designated with a Δ and may be prefixed with an N



COLDMASTER®

The Coldmaster solution **eliminates** the **inconvenience** and mess of ice, as well as reduces the potential for bacteria. The Coldmaster solution is **revolutionizing** the food pan category, offering **innovative** solutions and **making work easier**.



DineXpress
page 100



Tray Delivery Carts
page 142

Coldmaster = Peace of Mind

Coldmaster products are available in a variety of shapes and sizes from food pans to crocks, to ice cream servers. Coldmaster offers peace of mind while it keeps your food cold and fresh. Enjoy the convenience of Coldmaster, as it allows you to transport and keep food cold, anywhere you need to without messy ice or electricity.



Coldmaster Products Exceed Health Department Requirements

- With one overnight charge in your freezer, each Coldmaster keeps food at or below the ServSafe®* guidelines of 40°F for up to eight hours**

Coldmaster Products Meet FDA Standards

- All Coldmaster products are filled with an exclusive non-toxic refrigerant gel
- Constructed of high-impact ABS plastic
- Dishwasher safe



The Coldmaster Solution:

- High-impact ABS plastic holds up to foodservice use
- Exclusive refrigerant gel ensures high performance
Non-toxic gel receives a cold "charge" when frozen overnight, which enables it to keep your food cold throughout the day
- Extra insulation surrounds refrigerant gel for maximum cold retention
- Refrigerant gel is enclosed in a bag; prevents leaks, even if shell is damaged

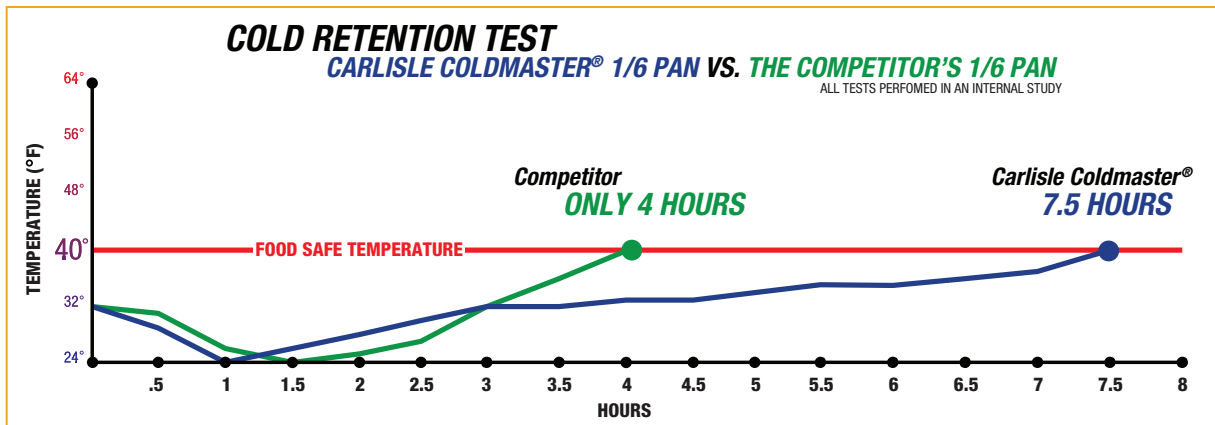

Coldmaster® CoolCheck™

- Patent-pending technology allows you to quickly see when temperatures are no longer safe
- Same great features as our standard Coldmaster products with the added element of color-changing technology
- Eliminates the guessing game behind food safety
- Unit holds food safely below 41°F for 6-8 hours*
- Reduces waste by “telling” workers when food temperature is safe
- Eliminates the mess and inconvenience of ice
- FDA approved; dishwasher safe
- Use Coldmaster Lids listed on pages 210-211
- NSF Listed

*Time will vary based on ambient room temperature



Designed to fit in standard sized food pan templates or food wells



Coldmaster® Whipped Cream & 1 Quart Carton Chillers

- Chillers use the same technology as standard Coldmaster pans
- CM1107 is designed to hold a standard 1qt carton; keeps dairy/egg cartons cold up to 8 hours**
- CM1108 is designed to hold a whipped cream can and provide food-safe chilling for up to 8 hours**
- NSF Listed



FoodService Prod No	Dinex Prod No	Description	Color	Pack
Coldmaster CoolCheck				
CM1100C14 Δ	DXCM1100C14 Δ	6" Deep Full-size Food Pan	02	1 ea
CM1125	DXCM1125	Full-size Coldmaster Lid	07	2 ea
CM1101C14 Δ	DXCM1101C14 Δ	6" Deep Half-size Food Pan	02	1 ea
CM1126	DXCM1126	Half-size Coldmaster Lid	07	2 ea
CM1102C14 Δ		6" Deep Third-size Food Pan	02	1 ea
CM1103C14 Δ		6" Deep Third-size Divided Food Pan	02	1 ea
CM1104C14 Δ		6" Deep Sixth-size Food Pan	02	1 ea
CM1105C14 Δ		6" Deep High Capacity Sixth-size Food Pan	02	1 ea
Coldmaster Chillers				
CM1107 Δ		1 Quart Carton Chiller	02, 03	1 ea
CM1108 Δ		Whipped Cream Can Chiller	02, 03	1 ea

NSF Listed products are designated with a Δ and may be prefixed with an N

*ServSafe is a registered trademark of the National Restaurant Association

**Temperature retention is based on crocks being pre-frozen for a minimum of eight hours, then filled directly with pre-chilled foods. Testing was conducted under ambient room temperatures of 76°F.



COLDMASTER®

Standard Food Pans & Lids

- Designed to fit in standard sized food pan templates
- Save time and labor by placing food directly into Coldmaster Standard Pans
- Third-size divided splits into two sixth-size food pans
- NSF Listed



Coldmaster Lids

- Designed to fit Coldmaster Standard Food Pans
- Clear acrylic lid protects against contaminants
- Helps maintain cold temperatures so your food stays fresh longer
- Molded-in handle allows easy removal



DineXpress
page 100



Tray Delivery Carts
page 142



Prod No	Description	Color	Pack
Coldmaster Standard Food Pans & Lids			
CM1100 Δ	6" Deep Full-size Food Pan	02, 03	1 ea
CM1101 Δ	6" Deep Half-size Food Pan	02, 03	1 ea
CM1102 Δ	6" Deep Third-size Food Pan	02, 03	1 ea
CM1103 Δ	6" Deep Third-size Divided Food Pan	02, 03	1 ea
CM1104 Δ	6" Deep Sixth-size Food Pan	02, 03	1 ea
CM1105 Δ	6" Deep High Capacity Sixth-size Food Pan	02, 03	1 ea
CM1125	Full-size Coldmaster Lid	07	2 ea
CM1126	Half-size Coldmaster Lid	07	2 ea
CM1127	Third-size Coldmaster Lid	07	2 ea
CM1128	Sixth-size Coldmaster Lid	07	2 ea

NSF Listed products are designated with a Δ and may be prefixed with an N

COLDMASTER® EZ ACCESS LIDS

Carlisle's EZ Access Lids were designed in **collaboration** with the people who **use our products everyday**.

Coldmaster EZ Access Lids

- Lids fit standard Coldmaster Food Pans shown on facing page
- Snug fit ensures they won't pop off, even when leveling a measure miser on the sidewall
- Innovative design includes lipped notches that allow the lid to be opened with a simple flick of the wrist or serving utensil
- Raised design allows maximum fill of your food pan
- Easy-clean design eliminates food traps and allows for easy cleanability
- Convenient hang hole for easy storage when not in use
- NSF Listed

Pan/Organizer with PC Food Pans and EZ Access Lids



CM1049



CM103190Z



CM10280Z

CM10240Z

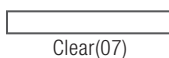

Clear(07)

Prod No	Description	Color	Pack
Coldmaster EZ Access Lids			
CM10238Z Δ \blacklozenge	1/2 Size Lid	07	2 ea
CM10239Z Δ \blacklozenge	1/2 Size Lid with Notch	07	2 ea
CM10240Z Δ \blacklozenge	1/2 Size Lid with 2 Notches	07	2 ea
CM10278Z Δ \blacklozenge	1/3 Size Lid	07	2 ea
CM10279Z Δ \blacklozenge	1/3 Size Lid with Notch	07	2 ea
CM10280Z Δ \blacklozenge	1/3 Size Lid with 2 Notches	07	2 ea
CM10318Z Δ \blacklozenge	1/6 Size Lid	07	2 ea
CM10319Z Δ \blacklozenge	1/6 Size Lid with Notch	07	2 ea

NSF Listed products are designated with a Δ and may be prefixed with an N
 \blacklozenge California Residents: Bisphenol A **WARNING:** See appendix A on page 281



COLDMASTER®

The **safest and most convenient** way to keep foods held in metal pans cold for **up to 8 hours** during outdoor or off-site events. Coldmaster Coldpans allow your operation to keep **limited-time-offer items** chilled **without having to expand your cold well.**

Pan/Organizer with standard Food Pans



Coldmaster Coldpans

- Designed with the same capacity as traditional style food pans; will hold DuraPan™ Food Pans (pages 201-202)
- Holds and keeps standard food pans cold
- CM1049 Pan Organizer is a 6" deep full size coldpan designed to hold (9) ninth-size food pans for easy organization
- NSF Listed, dishwasher safe



Prod No	Description	Color	Pack
Coldmaster Coldpans			
CM1042 Δ	6" Deep Full-size Coldpan (will hold full, third or half size pans)	02, 03	1 ea
CM1040 Δ	4" Deep Full-size Coldpan (will hold full, third or half size pans)	02	1 ea
CM1042LP	Full Size Coldpan Lid (fits CM1040, CM1042 and CM1049)	02	1 ea
CM1043 Δ	6" Deep Half-size Long Coldpan (will hold 1 half-long pan)	02	1 ea
CM1045 Δ	6" Deep Third-size Coldpan (will hold third, sixth or ninth size pans)	02	1 ea
CM1046 Δ	6" Deep Two-Thirds size Coldpan (will hold two-third or third size pans)	02	1 ea
Coldmaster Pan/Organizer			
CM1049	6" Deep Full-size Coldpan with Organizer (does not include food pans)	02	1 ea

NSF Listed products are designated with a Δ and may be prefixed with an N

Designer Coldmaster

- The same great features as our original Coldmaster with an attractive design that keeps food cold, appetizing and safe
- Keeps salads fresh and crisp for hours
- Provides a classy look for bar toppings
- Clear polycarbonate lids (sold separately) help preserve food freshness
- Crocks are NSF listed and dishwasher safe



Ice Cream Server & Lid

- Coldmaster technology and benefits (see page 208)
- Accommodates standard 3-gallon ice cream tubs
- FREE, clear polycarbonate lid included with each Coldmaster Ice Cream Server
- Replacement Lids (CM1013) also available



CM1012

CM1012 with 38655 Shroud

Ice Cream Shroud

- Attractive stainless steel cover offers an upscale appearance

White/White(02)	Black/Black(03)	Clear(07) Lids Only	White/Pewter(440)	Black/Charcoal(444)
White/Champagne(439)*	White/Charcoal(441)*	Black/Champagne(442)*	Black/Pewter(443)*	

Prod No	Description	Color	Pack
Designer Coldmaster – Stocked			
CM1400 Δ	1 qt Flared Square	02, 03, 440, 444	1 ea
CM1401 Δ	2 qt Flared Square	02, 03, 440, 444	1 ea
CM1402 Δ	5 qt Oval	02, 03, 440, 444	1 ea
Designer Coldmaster – Special Order*			
CM1400 Δ	1 qt Flared Square	439, 441, 442, 443	1 ea
CM1401 Δ	2 qt Flared Square	439, 441, 442, 443	1 ea
CM1402 Δ	5 qt Oval	439, 441, 442, 443	1 ea
Designer Coldmaster Lids			
CM1403 ◆	1 qt Lid Solid (fits CM1400)	07	1 ea
CM1404 ◆	1 qt Lid Notched (fits CM1400)	07	1 ea
CM1405 ◆	2 qt Lid Solid (fits CM1401)	07	1 ea
CM1406 ◆	2 qt Lid Notched (fits CM1401)	07	1 ea
CM1407 ◆	5 qt Lid Solid (fits CM1402)	07	1 ea
CM1408 ◆	5 qt Lid Notched (fits CM1402)	07	1 ea
Coldmaster Ice Cream Server, Lid & Shroud			
CM1012 Δ	3 gal Coldmaster Ice Cream Server	02, 03	1 ea
CM1013 ◆	Lid for Coldmaster Ice Cream Server	07	1 ea
38655	Coldmaster Ice Cream Shroud	—	1 ea

NSF Listed Products are designated with a Δ and may be prefixed with an N

*Special order colors require a MOQ of 400 pieces and 3 weeks lead time for production.

◆ California Residents: Bisphenol A **WARNING:** See appendix A on page 281



CARLISLE
FOODSERVICE PRODUCTS

EFFICIENT
DURABLE
INNOVATIVE
SMART
**WARE-
WASHING
PRODUCTS**

Carlisle offers every rack, basket and accessory you need for efficient warewashing operations. OptiClean™ is the industry standard for enabling clean, spotless ware. Our full line of color-coded rack extenders and Plaque-a-Racks are the ideal solution for sorting and managing your ware.



Items in this section are purchased through Carlisle FoodService Products and will ship separately from Dinex orders. Please contact your local sales representative for more information.



NEW CUSTOMIZATION

Hot Stamping

MOQ

150 eaches per customized rack
(must divide into case pack quantities)

Lead Time

3-4 weeks from receiving PO

Pricing

All pricing is calculated on net customer pricing plus a per piece charge

Per piece charge for hot stamp is net \$0.75/side

Set Up Charge

\$80 per stamp design

Only 3 sides available for inserts for NSF rated products

Artwork for hot stamp:

Digital artwork is required for all custom warewash products. Camera-ready art is defined as digital files in vector format. The preferred format includes Illustrator, Illustrator EPS or InDesign. PNG files (with a transparent background) may be submitted but must be a minimum of 300dpi at 100% of reproduction size. Decorating is limited to one color. Black or white imprint is standard stocked colors, contact Customer Service for a complete list of available imprint colors.

Size dimensions of artwork

3.5" x 1" tall

Sample

Digital sample to be provided

Inserts or stamps will be ordered with signed and approved artwork

Lead time for digital sample: 1-2 days (after receiving sufficient logo file)

No Returns

Color-Coded Base Racks

MOQ

300 eaches per customized rack
(must divide into case pack quantities)

Lead Time

3-4 weeks from receiving PO

Pricing

All pricing is calculated on net customer pricing plus a per piece charge

Per piece charge for custom colors is net \$1.30/rack

Colors Available

-  Red
-  Yellow
-  Orange
-  Green
-  Purple

Base Racks Available

RW20	RG16	RP	RC16
RW30	RG25	RTP	RC20
RG9	RG36	RB	
	RG49	RF	

No Returns

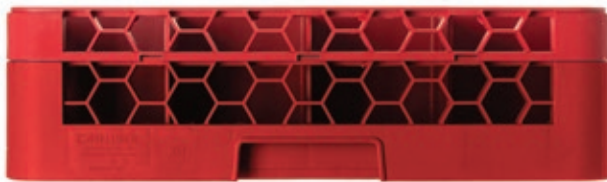

Inserts

MOQ

150 eaches per customized rack
(must divide into case pack quantities)

Lead Time

3-4 weeks from receiving PO

Pricing

All pricing is calculated on net customer pricing plus a per piece charge

Per piece charge for custom insert is net \$0.40/side

Set Up Charge

Inserts - \$1,000/side
Only 3 sides available for inserts for NSF rated products

Artwork for inserts:

Digital artwork is required for all custom warewash products. Camera-ready art is defined as digital files in vector format. The preferred format includes Illustrator, Illustrator EPS or InDesign. PNG files (with a transparent background) may be submitted but must be a minimum of 300dpi at 100% of reproduction size.

Size dimensions of artwork

3.5" x 1" tall

No Returns





How To Create The Correct Item Number For Your Washrack

- 1** Each item begins with an **R** for rack
- 2** Second digit indicates type
 - G** // Glass
 - W** // NeWave
 - C** // Cup
 - P** // Peg/Plate*
 - B** // Bowl*
 - F** // Flatware*
 - SP** // Sheet Pan*
 - FP** // Food Pan*
 - PC** // Plate Cover*
 - TP** // Tall Peg*
 - OP** // Open Peg*

**Skip to Step Six*
Only available in Blue(14)
- 3** Glass, NeWave (only 20 or 30) & Cup (only 16 or 20) racks have additional digits beginning with number of compartments
 - 9 // Nine Compartment
 - 16 // Sixteen Compartment
 - 20 // Twenty Compartment
 - 25** // Twenty-five Compartment
 - 30 // Thirty Compartment
 - 36 // Thirty-six Compartment
 - 49 // Forty-nine Compartment
- 4** To add extenders, add a dash and the # of extenders*
 - 1 // One Extender
 - 2 // Two Extenders
 - 3** // Three Extenders
 - 4 // Four Extenders
 - 5 // Five Extenders

* RW racks have a standard integrated extender, therefore an additional extender for each line listed above e.g. RW20-1 includes two extenders.
- 5** If you want color-coded extenders, add a **C** – Otherwise, skip this step
 - 410** // Red/Blue
 - 411 // Yellow/Blue
 - 412 // Orange/Blue
 - 413 // Green/Blue
 - 414 // Lavender/Blue
 - 14 // Blue
- 6** Lastly, add the color-code
- 7** This order is for a glass rack with 25 compartments, 3 extenders and the top extender is red.

RG25-3C410

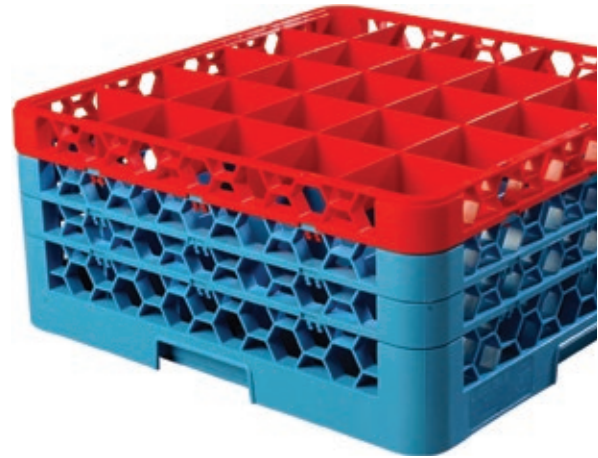
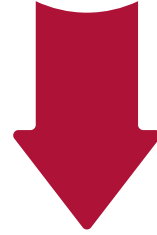

Extender Heights

No Extender	3-1/8"
1 Extender	4-5/8"
2 Extenders	6-1/8"
3 Extenders	7-5/8"
4 Extenders	9-1/8"
5 Extenders	10-5/8"

- Extenders are available in multiple colors including Blue(14), Yellow(04), Red(05), Green(09), Orange(24), Lavender(89)
- Additional accessories can be found at the web address below

Washrack Sizing

Rack #	Description	Min Dia	Max Dia	Min Dia	Max Dia	Dia for Handles
Standard						
RG49	49 Compartment Glass Rack	2"	2-3/8"	51 mm	60 mm	2-7/8"
RG36	36 Compartment Glass Rack	2-3/8"	2-3/4"	60 mm	70 mm	3-5/8"
RG25	25 Compartment Glass Rack	2-3/4"	3-3/8"	70 mm	86 mm	4-3/8"
RG16	16 Compartment Glass Rack	3-3/8"	4-3/8"	86 mm	111 mm	5-5/8"
RG9	9 Compartment Glass Rack	4-3/8"	5-7/8"	111 mm	149 mm	7-3/4"
NeWave						
RW30	Glass Rack w/ Integrated Extender 30 Compartment	2-5/8"	3"	67 mm	76 mm	
RW20	Glass Rack w/ Integrated Extender 20 Compartment	3"	3-3/4"	76 mm	95 mm	
Tilted Cup						
RC20	Tilted Cup Rack 20 Compartment	2-5/8"	4-1/4"	67 mm	108 mm	5-1/8"
RC16	Tilted Cup Rack 16 Compartment	4-1/4"	4-3/8"	108 mm	111 mm	6-5/8"

Find The Perfect Glass Rack

www.carlislefsp.com/FINDRACK

OptiClean NeWave Color-Coded Glass Racks

- Fits 25% more glasses which saves on chemical cost by washing more glasses per cycle
- Honeycomb design allows a free flow of soap and water and balanced weight dispersion when racks are stacked high
- Compatible stacking with standard dish racks ensuring a smooth transition to Carlisle washracks without interrupting workflow
- Color coded extenders allow for convenient identification
- Most durable rack in the market
- NSF Listed



NeWave 20-Compartment

- Use for glasses & tumblers

NeWave 30-Compartment

- Use for glasses & tumblers

Get more clean glasses per wash cycle. Check out the measurement chart on page 218 to find the most efficient wash rack for your glass size.



RW20



RW30-2

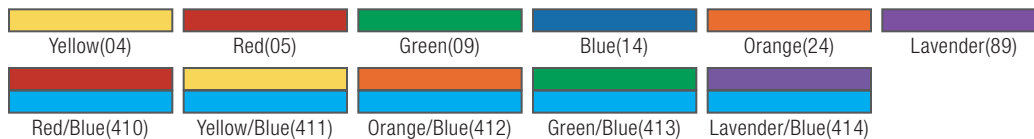

Prod No	Description	Glass Dia*	Glass Height	Color	Pack
20-Compartment NeWave Glass Rack - Compartment Size 3.81" Dia					
RW20 Δ	20-Compartment with Integrated Extender	3.56"	4.75"	14	4 ea
RW20-1 Δ	20-Compartment with 2 Extenders	3.56"	6.34"	14	3 ea
RW20-2 Δ	20-Compartment with 3 Extenders	3.56"	7.94"	14	2 ea
RW20-3 Δ	20-Compartment with 4 Extenders	3.56"	9.5"	14	2 ea
REW20S	20-Compartment Extender	3.56"	1.5"	14	6 ea
20-Compartment Color-Coded NeWave Glass Rack—Compartment Size 3.81" Dia					
REW20SC	20-Compartment Divided Extender	3.56"	1.5"	04, 05, 09, 24, 89	6 ea
RW20-C Δ	20-Compartment with Integrated Extender	3.56"	4.75"	410, 411, 412, 413, 414	4 ea
RW20-1C Δ	20-Compartment with 2 Extenders	3.56"	6.34"	410, 411, 412, 413, 414	3 ea
RW20-2C Δ	20-Compartment with 3 Extenders	3.56"	7.94"	410, 411, 412, 413, 414	2 ea
RW20-3C Δ	20-Compartment with 4 Extenders	3.56"	9.5"	410, 411, 412, 413, 414	2 ea
RW20-4C Δ	20-Compartment with 5 Extenders	3.56"	11.1"	410, 411, 412, 413, 414	1 ea
30-Compartment NeWave Glass Rack - Compartment Size 3.13" Dia					
RW30 Δ	30-Compartment with Integrated Extender	2.88"	4.75"	14	4 ea
RW30-1 Δ	30-Compartment with 2 Extenders	2.88"	6.34"	14	3 ea
RW30-2 Δ	30-Compartment with 3 Extenders	2.88"	7.94"	14	2 ea
RW30-3 Δ	30-Compartment with 4 Extenders	2.88"	9.5"	14	2 ea
REW30S	30-Compartment Extender	2.88"	1.5"	14	6 ea
30-Compartment Color-Coded NeWave Glass Rack—Compartment Size 3.13" Dia					
REW30SC	30-Compartment Divided Extender	3.56"	1.5"	04, 05, 09, 24, 89	6 ea
RW30-C Δ	30-Compartment with Integrated Extender	2.88"	4.75"	410, 411, 412, 413, 414	4 ea
RW30-1C Δ	30-Compartment with 2 Extenders	2.88"	6.34"	410, 411, 412, 413, 414	3 ea
RW30-2C Δ	30-Compartment with 3 Extenders	2.88"	7.94"	410, 411, 412, 413, 414	2 ea
RW30-3C Δ	30-Compartment with 4 Extenders	2.88"	9.5"	410, 411, 412, 413, 414	2 ea
RW30-4C Δ	30-Compartment with 5 Extenders	2.88"	11.1"	410, 411, 412, 413, 414	1 ea

NSF Listed products are designated with a Δ and may be prefixed with an N

*Dimensions shown are for the recommended maximum glass size for the compartment



OPTICLEAN®

9-Compartment

- Use with large brandy snifters, grande margaritas, carafes and other items with a wide diameter



RG9-1

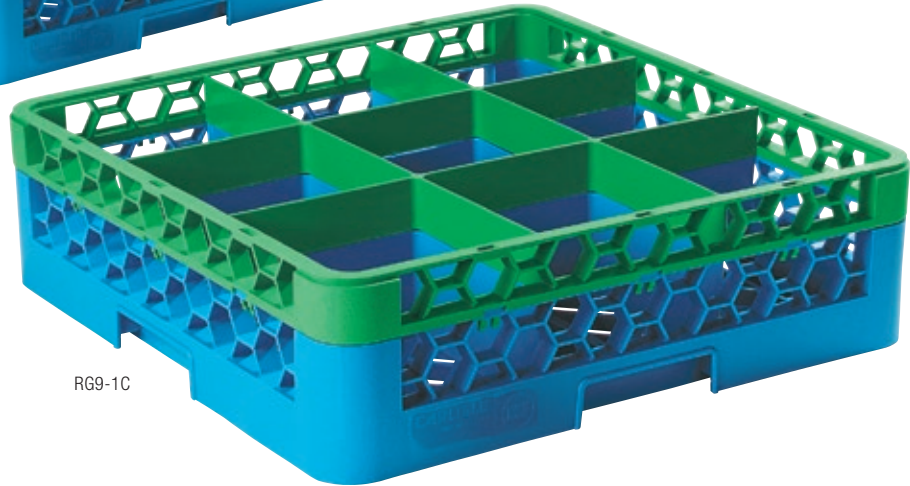

RG9-1C



Dinex Tumblers

page 38



Washrack Dispensers

page 137

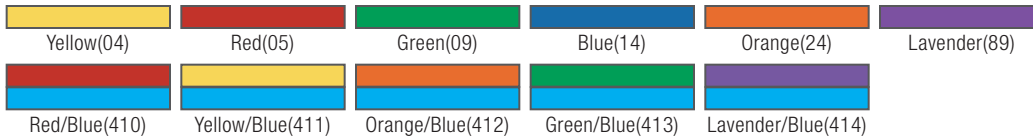

Prod No	Description	Glass Dia**	Glass Height	Color	Pack
9-Compartment Glass Rack—Compartment Size 5.83" Square					
RG9 Δ	9-Compartment	5.56"	3.19"	14	6 ea
RG9-1 Δ	9-Compartment with 1 Extender	5.56"	4.75"	14	4 ea
RG9-2 Δ	9-Compartment with 2 Extenders	5.56"	6.34"	14	3 ea
RG9-3 Δ	9-Compartment with 3 Extenders	5.56"	7.94"	14	2 ea
RG9-4 Δ	9-Compartment with 4 Extenders	5.56"	9.5"	14	2 ea
RG9-5 Δ	9-Compartment with 5 Extenders	5.56"	11.1"	14	2 ea
RE9	9-Compartment Divided Extender	5.56"	9.5"	14	6 ea
RE*	Open Extender	—	1.5"	14	6 ea
9-Compartment Color-Coded Glass Rack—Compartment Size 5.83" Square					
RG9-1C Δ	9-Compartment with 1 Extender	5.56"	4.75"	410, 411, 412, 413, 414	4 ea
RG9-2C Δ	9-Compartment with 2 Extenders	5.56"	6.34"	410, 411, 412, 413, 414	3 ea
RG9-3C Δ	9-Compartment with 3 Extenders	5.56"	7.94"	410, 411, 412, 413, 414	2 ea
RG9-4C Δ	9-Compartment with 4 Extenders	5.56"	9.5"	410, 411, 412, 413, 414	2 ea
RG9-5C Δ	9-Compartment with 5 Extenders	5.56"	11.1"	410, 411, 412, 413, 414	2 ea
RE9C	9-Compartment Divided Extender	5.56"	1.5"	04, 05, 09, 24, 89	6 ea
RE*	Open Extender	—	1.5"	14	6 ea

NSF Listed products are designated with a Δ and may be prefixed with an N

*Note: The RE Open Extender can be used with any OptiClean Glass or Dish Rack

**Dimensions shown are for the recommended maximum glass size for the compartment

16-Compartment

- Perfect for large cocktail glasses and delicate wine stems with oversize bowls

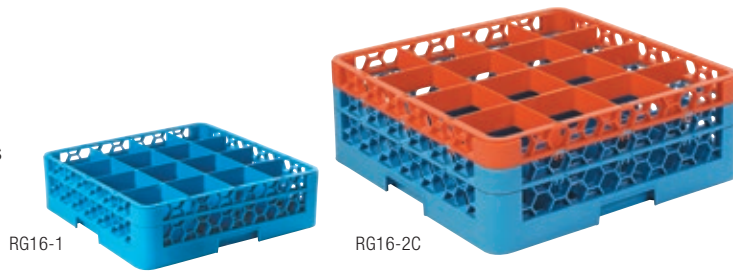

Prod No	Description	Glass Dia**	Glass Height	Color	Pack
16-Compartment OptiClean Glass Rack—Compartment Size 4.45" Square					
RG16 Δ	16-Compartment	4.19"	3.19"	14	6 ea
RG16-1 Δ	16-Compartment with 1 Extender	4.19"	4.75"	14	4 ea
RG16-2 Δ	16-Compartment with 2 Extenders	4.19"	6.34"	14	3 ea
RG16-3 Δ	16-Compartment with 3 Extenders	4.19"	7.94"	14	2 ea
RG16-4 Δ	16-Compartment with 4 Extenders	4.19"	9.5"	14	2 ea
RG16-5 Δ	16-Compartment with 5 Extenders	4.19"	11.1"	14	2 ea
RE16	16-Compt Divided Extender	4.19"	1.5"	14	6 ea
RE*	Open Extender	—	1.5"	14	6 ea
16-Compartment OptiClean Color-Coded Glass Rack—Compartment Size 4.45" Square					
RG16-1C Δ	16-Compartment with 1 Extender	4.19"	4.75"	410, 411, 412, 413, 414	4 ea
RG16-2C Δ	16-Compartment with 2 Extenders	4.19"	6.34"	410, 411, 412, 413, 414	3 ea
RG16-3C Δ	16-Compartment with 3 Extenders	4.19"	7.94"	410, 411, 412, 413, 414	2 ea
RG16-4C Δ	16-Compartment with 4 Extenders	4.19"	9.5"	410, 411, 412, 413, 414	2 ea
RG16-5C Δ	16-Compartment with 5 Extenders	4.19"	11.1"	410, 411, 412, 413, 414	2 ea
RE16C	16-Compartment Divided Extender	4.19"	1.5"	04, 05, 09, 24, 89	6 ea
RE*	Open Extender	—	1.5"	14	6 ea

25-Compartment

- Use for large diameter beverage glasses, red wine stems, goblets and most rocks glasses

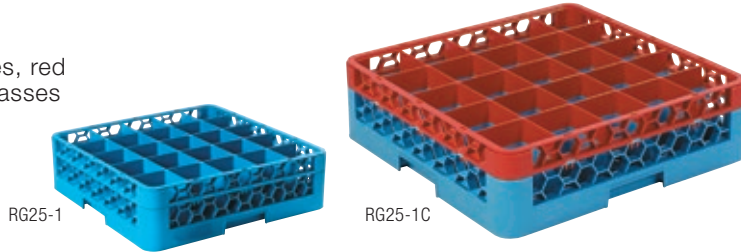

Prod No	Description	Glass Dia**	Glass Height	Color	Pack
25-Compartment OptiClean Glass Rack—Compartment Size 3.54" Square					
RG25 Δ	25-Compartment	3.25"	3.19"	14	6 ea
RG25-1 Δ	25-Compartment with 1 Extender	3.25"	4.75"	14	4 ea
RG25-2 Δ	25-Compartment with 2 Extenders	3.25"	6.34"	14	3 ea
RG25-3 Δ	25-Compartment with 3 Extenders	3.25"	7.94"	14	2 ea
RG25-4 Δ	25-Compartment with 4 Extenders	3.25"	9.5"	14	2 ea
RG25-5 Δ	25-Compartment with 5 Extenders	3.25"	11.1"	14	2 ea
RE25	25-Compartment Divided Extender	3.25"	1.5"	14	6 ea
RE*	Open Extender	—	1.5"	14	6 ea
25-Compartment OptiClean Color-Coded Glass Rack—Compartment Size 3.54" Square					
RG25-1C Δ	25-Compartment with 1 Extender	3.25"	4.75"	410, 411, 412, 413, 414	4 ea
RG25-2C Δ	25-Compartment with 2 Extenders	3.25"	6.34"	410, 411, 412, 413, 414	3 ea
RG25-3C Δ	25-Compartment with 3 Extenders	3.25"	7.94"	410, 411, 412, 413, 414	2 ea
RG25-4C Δ	25-Compartment with 4 Extenders	3.25"	9.5"	410, 411, 412, 413, 414	2 ea
RG25-5C Δ	25-Compartment with 5 Extenders	3.25"	11.1"	410, 411, 412, 413, 414	2 ea
RE25C	25-Compartment Divided Extender	3.25"	1.5"	04, 05, 09, 24, 89	6 ea
RE*	Open Extender	—	1.5"	14	6 ea

NSF Listed products are designated with a Δ and may be prefixed with an N

*Note: The RE Open Extender can be used with any OptiClean Glass or Dish Rack

**Dimensions shown are for the recommended maximum glass size for the compartment



OPTICLEAN®

36-Compartment

- Use with tumblers, white wine glasses and other narrow bowl stems

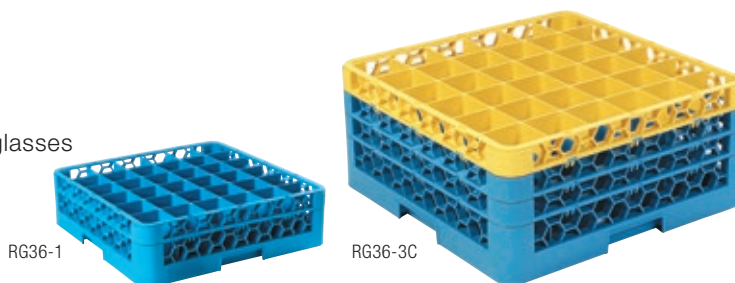

Prod No	Description	Glass Dia**	Glass Height	Color	Pack
36-Compartment OptiClean Glass Rack—Compartment Size 2.94" Square					
RG36 Δ	36-Compartment	2.69"	3.19"	14	6 ea
RG36-1 Δ	36-Compartment with 1 Extender	2.69"	4.75"	14	4 ea
RG36-2 Δ	36-Compartment with 2 Extenders	2.69"	6.34"	14	3 ea
RG36-3 Δ	36-Compartment with 3 Extenders	2.69"	7.94"	14	2 ea
RG36-4 Δ	36-Compartment with 4 Extenders	2.69"	9.5"	14	2 ea
RG36-5 Δ	36-Compartment with 5 Extenders	2.69"	11.1"	14	2 ea
RE36	36-Compartment Divided Extender	2.69"	1.5"	14	6 ea
RE*	Open Extender/Hgt: 1.5"	—	1.5"	14	6 ea
36-Compartment OptiClean Color-Coded Glass Rack—Compartment Size 2.94" Square					
RG36-1C Δ	36-Compartment with 1 Extender	2.69"	4.75"	410, 411, 412, 413, 414	4 ea
RG36-2C Δ	36-Compartment with 2 Extenders	2.69"	6.34"	410, 411, 412, 413, 414	3 ea
RG36-3C Δ	36-Compartment with 3 Extenders	2.69"	7.94"	410, 411, 412, 413, 414	2 ea
RG36-4C Δ	36-Compartment with 4 Extenders	2.69"	9.5"	410, 411, 412, 413, 414	2 ea
RG36-5C Δ	36-Compartment with 5 Extenders	2.69"	11.1"	410, 412, 413, 414	2 ea
RE36C	36-Compartment Divided Extender	2.69"	1.5"	04, 05, 09, 24, 89	6 ea

49-Compartment

- Ideal for juice glasses, narrow champagne flutes, cordials and shot glasses

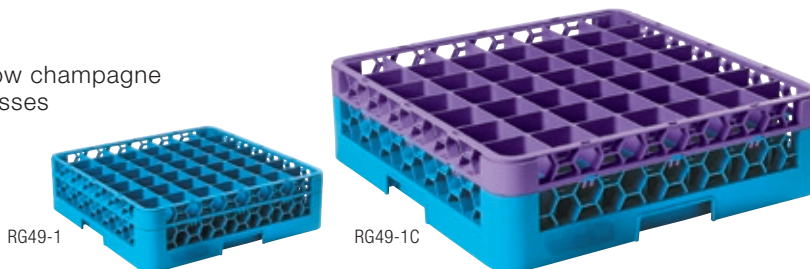

Prod No	Description	Glass Dia**	Glass Height	Color	Pack
49-Compartment Glass Rack—Compartment Size 2.91" Square					
RG49 Δ	49-Compartment	2.13"	3.19"	14	6 ea
RG49-1 Δ	49-Compartment with 1 Extender	2.13"	4.75"	14	4 ea
RG49-2 Δ	49-Compartment with 2 Extenders	2.13"	6.34"	14	3 ea
RG49-3 Δ	49-Compartment with 3 Extenders	2.13"	7.94"	14	2 ea
RG49-4 Δ	49-Compartment with 4 Extenders	2.13"	9.5"	14	2 ea
RE49	49-Compartment Divided Extenders	2.13"	1.5"	14	6 ea
RE*	Open Extender	—	1.5"	14	6 ea
49-Compartment Color-Coded Glass Rack—Compartment Size 2.91" Square					
RG49-1C Δ	49-Compartment with 1 Extender	2.13"	4.75"	410, 411, 412, 413, 414	4 ea
RG49-2C Δ	49-Compartment with 2 Extenders	2.13"	6.34"	410, 411, 412, 413, 414	3 ea
RG49-3C Δ	49-Compartment with 3 Extenders	2.13"	7.94"	410, 411, 412, 413, 414	2 ea
RG49-4C Δ	49-Compartment with 4 Extenders	2.13"	9.5"	410, 411, 412, 413, 414	2 ea
RG49-5C Δ	49-Compartment with 5 Extenders	2.13"	11.1"	410, 411, 412, 413, 414	2 ea
RE49C	49-Compartment Divided Extender	2.13"	1.5"	04, 05, 09, 24, 89	6 ea

NSF Listed products are designated with a Δ and may be prefixed with an N

*Note: The RE Open Extender can be used with any OptiClean Glass or Dish Rack

**Dimensions shown are for the recommended maximum glass size for the compartment

Dish Racks

OptiClean Dish Racks offer the safest and most sanitary cleaning choices for everything from the most fragile tableware to heavy-duty kitchen items such as utensils and cutlery. These racks are NSF Listed and offer all the same great features as the rest of Carlisle's wash racks such as sturdy double wall construction and Comfort Curve™ Handles molded into all four sides.



Peg Racks

- Holds plates, trays, and platters at the best angle to take full advantage of today's multiple spray, high-pressure dishwashers
- Plate locks hold dishes firmly in place to protect delicate rims, reduce chipping and breakage
- Use with additional Open Extenders (RE) to create the perfect rack for irregular or oversize drinkware
- NSF Listed

Tall Peg Plate & Tray Rack

- Extra tall 2.94" pegs are ideal for charger plates, pasta bowls, large platters, and trays

Open End Peg Rack

- Tall 2.94" pegs with open ended design hold all types of trays, standard size baking sheets, and other long items

Open/Bowl Rack

- Sturdy open bottom rack is ideal for all large bowls, containers, brushes, cookware, and cutlery

Combination/Flatware Rack

- Bottom grid allows for free flow of water and air
- Keeps flatware in place for thorough washing and drying
- Perfect for ramekins, and other small items
- NSF Listed

 Blue(14)



RTP

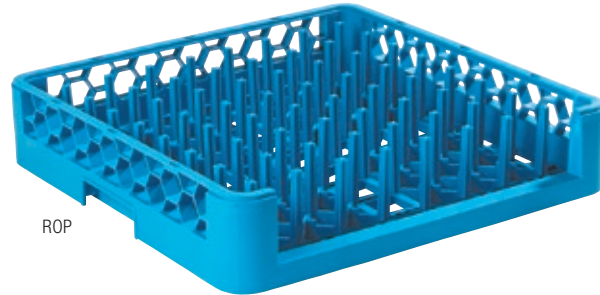

ROP



RB



RF

Prod No	Description	Color	Pack
Peg Racks & Extender			
RP	All-Purpose Plate & Tray Rack	14	6 ea
RTP Δ	Tall Peg Plate & Tray Rack	14	6 ea
ROP Δ	Open End Peg Rack	14	6 ea
RE*	Open Extender	14	6 ea
Open/Bowl Rack & Extender			
RB Δ	Open/Bowl Rack	14	6 ea
RE*	Open Extender	14	6 ea
Combination/Flatware Rack			
RF Δ	Combination/Flatware Rack	14	6 ea
RE*	Open Extender	14	6 ea

NSF Listed products are designated with a Δ and may be prefixed with an N
 * Note: The RE Open Extender can be used with any OptiClean Glass or Dish Rack



OPTICLEAN®

Cup Racks

- Tilted design promotes thorough washing of rims and interiors
- Encourages bases to drain more efficiently
- 16-Compartment holds larger diameter cups and mugs in tilted position; compartment size: 4.34" x 4.34"
- 20-Compartment works with most standard size cups; compartment size: 4.34" x 3.41"
- NSF Listed



RC20-1



RSP



RFP



RPC

Bakery Tray & Sheet Pan Rack

- Rack securely holds sheet or bun pans low enough to fit standard height dish machine openings
- Contents are angled to take full advantage of multiple spray arms
- NSF Listed

Food Pan/Insulated Meal Delivery Tray Rack

- Accommodates all sizes of 2.5" deep food pans and standard steam table inserts
- Racks are angled for thorough cleaning
- Perfect for health care or correctional facilities using insulated meal delivery compartment trays
- NSF Listed

Plate Cover Rack

- Use with plate covers, dishwasher safe insulated dome covers, or dishwasher safe pellet bases
- Specially designed insert keeps contents separated during washing
- NSF Listed

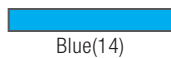

Prod No	Description	Color	Pack
Cup Racks			
RC16 Δ	16-Compartment Cup Rack	14	6 ea
RC16-1 Δ	16-Compartment Cup Rack with 1 Open Extender	14	4 ea
RC20 Δ	20-Compartment Cup Rack	14	6 ea
RC20-1 Δ	20-Compartment Cup Rack with 1 Open Extender	14	4 ea
Bakery Tray & Sheet Pan Rack			
RSP Δ	Bakery Tray & Sheet Pan Rack	14	3 ea
Food Pan/Insulated Meal Delivery Tray Rack			
RFP Δ	Food Pan/Insulated Meal Delivery Tray Rack	14	3 ea
Plate Cover Rack			
RPC Δ	Plate Cover Rack	14	3 ea

NSF Listed products are designated with a **Δ** and may be prefixed with an N

OPTICLEAN® ACCESSORIES

Hold Down Grid

- Use with small, light-weight, or delicate items to prevent them from being displaced by high pressure sprayers
- Snaps down securely and fits all OptiClean Glass & Dish Racks
- NSF Listed

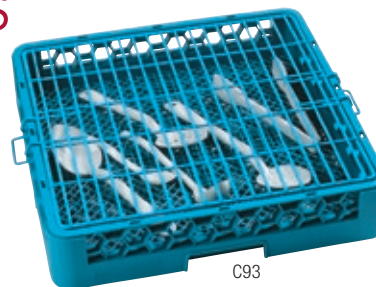

Half Size Stack-All™ Racks

- Compact 10" x 19.75" size will work in any 19.75" dishwasher
- Sturdy single wall construction
- Open design for superior water and air circulation
- Made of high impact polypropylene
- NSF Listed

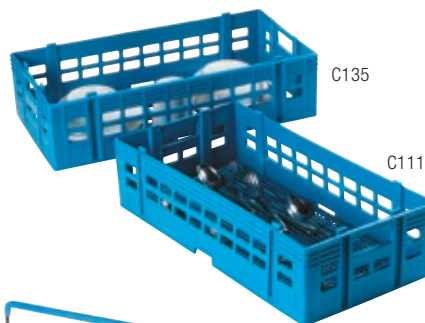

Perma-Sil™ Cylinders & Carriers

Flatware Cylinders

- Meshed bottom and open sides are best for the dispersion of water and air; ideal for washing or storing flatware

Carriers

- Heavy gauge wire construction is chrome plated
- Vinyl-coated insulated handle

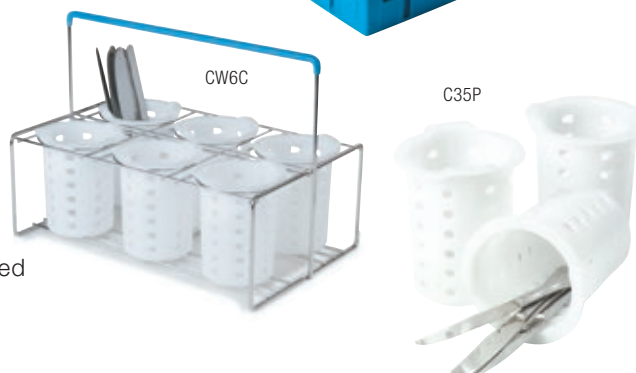

Perma-San™ Flatware Washing Baskets

- Open design for easy cleaning of vertically stored flatware
- Use with RF Flatware Rack or RB Open/Bowl Rack as part of a complete flatware sanitizing system
- Tough polypropylene material resists grease and detergents
- C32P1 and C32P2 are NSF Listed

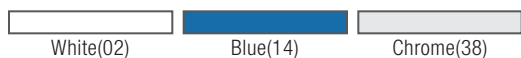
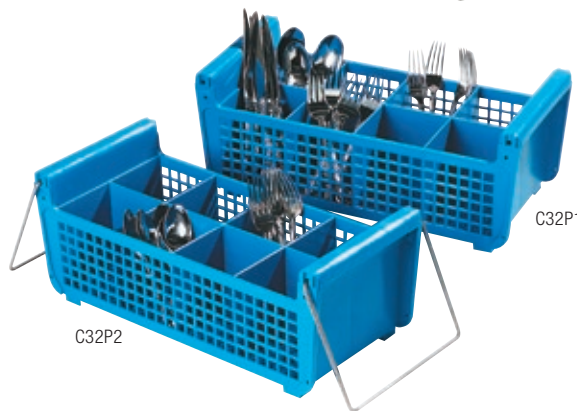

Prod No	Description	Glass Height	Color	Pack
Hold Down Grid				
C93 ▲	Vinyl Coated Wire Grid	—	14	6 ea
Half Size Stack-All Racks				
C135 ▲	Open Bowl/Cup/Glass Rack	4.5"	14	6 ea
C111 ▲	Flatware Rack	4.5"	14	6 ea
Perma-Sil Cylinders & Carriers				
C35P	Poly Cylinder	—	02	12 ea
CW6C	6-Compartment Portable Carrier	—	38	6 ea
C32P1 ▲	Flatware Basket without Handles	—	14	6 ea
C32P2 ▲	Flatware Basket with Handles	—	14	6 ea

NSF Listed products are designated with a ▲ and may be prefixed with an N



OPTICLEAN® ACCESSORIES

E-Z Glide™ Rack Dollies

Aluminum Dollies

- Hold and transport any 19.75" square stack of glass racks
- Large 4" ball bearing swivel casters with non-marking rubber wheels
- 300 lb weight capacity

Polypropylene Dollies

- C2236/C2236H injection molded dollies squared corners are designed to hold any standard 19.75" racks including older style square racks
- 350 lb weight capacity
- Dollies trap water from wet racks; convenient drain feature underneath the dolly makes emptying water easy



Dust Cover

- Heavy-duty vinyl covers keep tableware clean during storage
- Easily converts warewashing racks into storage racks
- Combine with E-Z Glide Dollies and Rack Covers (shown left) for a complete storage system

Rack Cover

- Hard cover protects rack contents during storage



Prod No	Description	Color	Pack
E-Z Glide Rack Dollies			
C2220A	Open Aluminum Dolly, No Handle	14	1 ea
C2222A	Open Aluminum Dolly with Handle	14	1 ea
C2236	Warewashing Rack Dolly, No Handle	03, 14	1 ea
C2236H	Warewashing Rack Dolly with Handle	03, 14	1 ea
C2237	Handle for C2236 & C2236H	03	1 ea
C2222C	Replacement Caster for C2220A & C2222A	00	1 ea
C2222HD	Handle for C2220A & C2222A	38	1 ea
Rack Cover			
RHC	Rack Cover	02	1 ea
Dust Covers			
RDC ♦	36" Long Rack Dust Cover	07	3 ea
RDC1 ♦	48" Long Rack Dust Cover	07	3 ea

NSF Listed products are designated with a **Δ** and may be prefixed with an N

♦ California Residents: Di(2-ethylhexylphthalate (DEHP) **WARNING:** See appendix B on page 281

BUS BOXES

Tote Boxes

- Unique reinforced rims reduce bending, bowing, and breaking
- Excellent for storing and separating food products
- Comfort Curve™ handles for a sure, comfortable grip
- Contour lid design allows easy box-on-box stacking
- Available in 8 different colors for HACCP zone use
- NSF Std 21 – meets the criteria for thermoplastic refuse containers
- NSF Std 2 – meets the criteria for food contact and cleanability

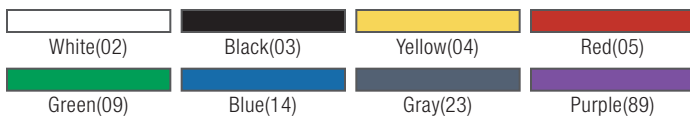

Prod No	Description	Color	Pack
Tote Boxes			
N44010 Δ	Tote Box 15" x 20" x 5" Deep	02, 03, 04, 05, 09, 14, 23, 89	12 ea
N44011 Δ	Tote Box 15" x 20" x 7" Deep	02, 03, 04, 05, 09, 14, 23, 89	12 ea
N44012 Δ	Universal Lid	02, 03, 04, 05, 09, 14, 23, 89	12 ea

NSF Listed products are designated with a Δ and may be prefixed with an N



CARLISLE
FOODSERVICE PRODUCTS

PROVEN
EFFICIENT
RELIABLE
**CLEANING
TOOLS**

Trust Carlisle's equipment cleaning brushes and kitchen tools to help keep your food service operation healthy, safe and profitable. These products are another way Carlisle helps you make work easy.



Items in this section are purchased through Carlisle FoodService Products and will ship separately from Dinex orders. Please contact your local sales representative for more information.

COLOR-CODED BRUSHES



Atlas™ Multi-Purpose Brushes

- Versatile design for a wide variety of applications
- Multiple trim angles on bristles give you better surface contact for better cleaning
- Available with ergonomic pistol grip handles in 8" and 20" lengths
- Rugged plastic handles and crimped staple set polyester bristles will not absorb oils or moisture
- Base resins used to produce blocks and bristles are made of FDA compliant materials
- Full color-coded products offer easy identification for tool segregation



	Allergen Control
	Dairy or Dry Food
	Produce
	Prepared Food
	Meat
	Fish
	Poultry

Cutting Board Brushes

- Ergonomically shaped handles and crimped staple set polyester bristles are rugged and will not absorb food oils or moisture
- Segregate brushes and boards by color to help prevent cross contamination
- Base resins used to product blocks and bristles are made of FDA compliant materials



White(02)	Black(03)	Yellow(04)	Red(05)	Green(09)
Blue(14)	Tan(25)	Purple(68)	Purple(89)	

Prod No	Description	Recommended Cleaning	Color	Pack
Atlas Multi-Purpose Brushes				
40000	12" Handle, 2.75" Round with Soft Polyester Bristles	Drinkware/Dishes	02, 25	12 ea
40000C	12" Handle, 2.75" Round with Soft Polyester Bristles, Color-Coded	Drinkware/Dishes	02, 04, 05, 09, 14	6 ea
40001	16" Handle, 3.25" Round with Soft Polyester Bristles	Drinkware/Dishes	02, 03, 68	12 ea
40001C	16" Handle, 3.25" Round with Soft Polyester Bristles, Color-Coded	Drinkware/Dishes	02, 04, 05, 09, 14	6 ea
40002	16" Handle, 3.5" x 5" Oval with Polyester Bristles	Pots/Pans/Tanks	02	6 ea
40002C	16" Handle, 3.5" x 5" Oval with Polyester Bristles, Color-Coded	Pots/Pans/Tanks	04, 05, 09, 14	6 ea
40003	30" Handle, 3.5" x 5" Oval with Polyester Bristles	Pots/Pans/Tanks	02	6 ea
40003C	30" Handle, 3.5" x 5" Oval with Polyester Bristles, Color-Coded	Pots/Pans/Tanks	04, 05, 09, 14	6 ea
40004	16" Handle, 3" Round with Polyester Bristles	Pots/Pans/Tanks	02	6 ea
40004C	16" Handle, 3" Round with Polyester Bristles, Color-Coded	Pots/Pans/Tanks	04, 05, 09, 14	6 ea
40005	16" Handle, 4" Round with Polyester Bristles	Pots/Pans/Tanks	02	6 ea
40005C	16" Handle, 4" Round with Polyester Bristles, Color-Coded	Pots/Pans/Tanks	04, 05, 09, 14	6 ea
40006	30" Handle, 3" Round with Polyester Bristles	Pots/Pans/Tanks	02	6 ea
40006C	30" Handle, 3" Round with Polyester Bristles, Color-Coded	Pots/Pans/Tanks	04, 05, 09, 14	6 ea
40007	30" Handle, 4" Round with Polyester Bristles	Pots/Pans/Tanks	02	6 ea
40007C	30" Handle, 4" Round with Polyester Bristles, Color-Coded	Pots/Pans/Tanks	04, 05, 09, 14	6 ea
40008	30" Handle, 5" Round with Polyester Bristles	Pots/Pans/Tanks	02	6 ea
40008C	30" Handle, 5" Round with Polyester Bristles, Color-Coded	Pots/Pans/Tanks	04, 05, 09, 14	6 ea
40010	16" Handle, 5" Round with Polyester Bristles	Pots/Pans/Tanks	02	6 ea
40010C	16" Handle, 5" Round with Polyester Bristles, Color-Coded	Pots/Pans/Tanks	04, 05, 09, 14	6 ea
Cutting Board Brush				
40521	6" Cutting Board Brush with Polyester Bristles, 1.38" trim	—	02, 04, 05, 09, 14, 25, 89*	12 ea

*Color available by special order only

All Purpose Utility Scrub Brushes

- Brushes offer a thick “pistol grip” block handle and short, stiff bristles for really tough cleaning
- Light-weight, break-resistant, “soak-proof” plastic handles are perfect for clean up in a foodservice environment
- Rugged construction with stapleset secure bristles
- Full color-coded products offer easy identification for tool segregation



Dual Surface Brushes

- Recommended use: Cleaning kitchen floors, under counters, around equipment and along baseboards
- Floor scrubs are made with three different brush surfaces for cleaning at different angles
- Non-absorbent plastic blocks and synthetic bristles wash easily and prevent gathering of mold and mildew



Recommended handle sold separately on page 246

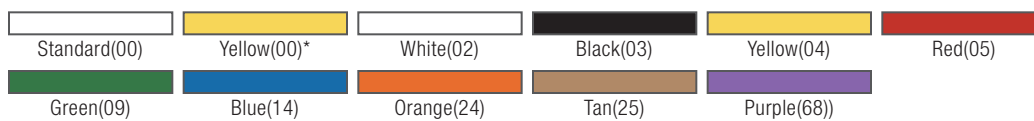

Prod No	Description	Recommended Cleaning	Color	Pack
All Purpose Utility Scrub Brushes				
40541	8" Utility Scrub Brush with Polyester Bristles, 2" trim	Pots/Pan/Medium Scrubbing	02, 04, 05, 09, 14, 24, 25, 68	12 ea
40501	20" Utility Scrub Brush with Polyester Bristles, 2" trim	Pots/Pan/Medium Scrubbing	02, 03, 05**, 14**, 24, 25, 68	12 ea
40501C	20" Color-Coded, Polyester Utility Scrub Brush Polyester Bristles, 2" trim	Pots/Pan/Medium Scrubbing	02, 04, 05, 09, 14	6 ea
40545	8" Brush with Medium Stiff Polyester Bristles, 1.6" trim	Pots/Pan/Medium Scrubbing	00	12 ea
40546	8" Brush with Medium Stiff Polyester Bristles, 1.6" trim	Pots/Pan/Medium Scrubbing	02	12 ea
40542	8" Brush with Medium Stiff Nylon Bristles, 1.4" trim	Pots/Pan/Medium Scrubbing	00	12 ea
40500	20" Brush with Medium Stiff Nylon Bristles, 1.6" trim	Pots/Pan/Medium Scrubbing	00	12 ea

Prod No	Description	Handle	Color	Pack
Dual Surface Brushes				
40423	10" Hi-Lo Floor Scrub Brush	Threaded	01, 02, 03, 04, 05, 09, 24, 68	12 ea
40422	10" Dual Surface Scrub Brush with End Bristles	Threaded	00*, 05, 09, 14	12 ea

**Color available by special order only

EQUIPMENT CLEANING BRUSHES



High Temp Fryer Brushes

- Made of stiff, PTFE bristles that withstand temperatures up to 500°F
- Saves time since equipment can be cleaned while hot
- Plastic handles stay cool to the touch
- 40110 Fryer Brush is 28" long to reach tight, narrow spaces
- 40112 Looped Brush cleans fryer bottoms easily
- 40111 and 40116 L-Tipped Fryer Brush for cleaning hot coils
- 40113 Utility Brush for cleaning hot vats, utensils and other equipment
- 40529 has 2.5" long, extra stiff nylon bristles reach through the grid of stainless steel cutters
- 40532 has 4.25" long, extra stiff, nylon bristles

Oven & Grill Brushes

- Wire brushes and stainless steel metal scrapers make quick and easy removal of heavy carbon deposits, rust and burned-on food build up
- Broiler Master and Double Broiler King rust-proof bristles are embedded in a rugged specially treated hardwood block for long-lasting cleaning power.
- 41520 and 40291 Oven Brushes have crimped brass wire bristles and full length stainless steel scrapers for cleaning high-temperature stack ovens.
- 40293 Oven Brush has crimped brass wire bristles and a full length aluminum scraper on a low-profile head for cleaning narrow spaces inside pizza ovens.
- 45772 Pizza/BBQ Oven Brush features steel wire bristles and a permanent 39" hardwood handle.
- 363725 Oven & Grill Brush has flat wire stainless steel bristles, oven scraper and a 30" handle.

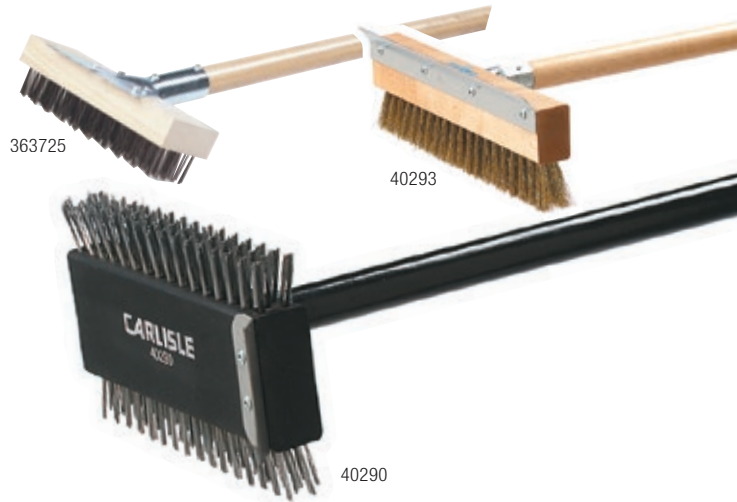

Prod No	Description	Trim	Color	Pack	
High Temp Fryer Brushes					
40110	28" Straight Fryer Brush with Teflon Bristles	1.38"	05	12 ea	
40112	24" Looped Fryer Brush with Teflon Bristles	2"	05	6 ea	
40111	23" L-Tipped Fryer Brush with Teflon Bristles	.88"	05	12 ea	
40113	20" Utility Brush with Teflon Bristles	2"	05	12 ea	
Oven & Grill Brushes					
40026	8.5" Broiler Master Brush, Carbon Steel Bristles with 30" Handle		00	6 ea	
40290	8.5" Broiler Master Brush, Stainless Steel Bristles with 30" Handle		00	6 ea	
40294	8" Double Broiler King, Carbon Steel Flat & Wire Bristles with 48" Handle		00	2 ea	
41520	8.5" Oven Brush & Scraper, Brass Wire Bristles with 42" Handle		00	1 ea	
40291*	8.5" Oven Brush & Scraper, Brass Wire Bristles (Head Only)		00	12 ea	
40293*	10" Oven Brush & Scraper, Brass Wire Bristles (Head Only)		00	12 ea	
45772	5.5" Pizza/BBQ Oven Brush, Carbon Steel Bristles and 33" Handle		00	12 ea	
363725	8" Oven Brush with Scraper, Flat Wire Stainless Steel Bristles with 30" Handle		00	1 ea	
Metal Threaded Handles					
40275	40" Metal Tip Wood Handle	.88"	Metal Thread	00	12 ea

*40291 & 40293 do not include handles; use with handle 40275 shown above
 NOTE: Heat coil must be turned off prior to using high temperature brushes

UPRIGHT BROOMS

Carlisle's upright brooms are **designed for extended use and offer superior performance**. Whether you're sweeping a lobby, kitchen floor or parking lot, we have a **high quality solution for you**.



TOP SELLER

36865

36885



Duo-Sweep® Angled

- For reaching into corners, along walls and into hard to reach areas
- Block made with tough & durable material that resists cracking, splitting and chipping
- Color coded angle brooms have one handle hole making them more hygienic and HAACP compliant
- Standard color (00) angle brooms have two handle holes; one angled, one upright

Recycled Angle Broom

- Contains 80% recycled flagged PET bristles and 60% recycled polypropylene copolymer shroud for increased stability
- Includes 48" durable vinyl coated metal handle with swivel hanging cap for storage



40650



Standard Bristles
41083

Flagged Bristles
41082

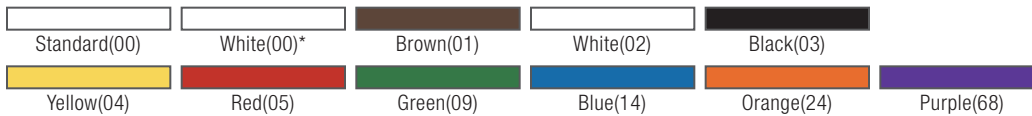

Prod No	Description	Bristle Length	Color	Pack
Flagged Duo-Sweep Angle Brooms				
36861	6.5" Flagged Duo-Sweep Angle Broom with 30" Metal Handle	5.5" - 7"	00	12 ea
36865	12" Flagged Duo-Sweep Medium Duty Angle Broom with 48" Metal Handle	5.5" - 7"	00	12 ea
41082	12" Flagged Duo-Sweep Broom with 48" Fiberglass Handle	5.5" - 7"	01, 02, 04, 05, 09, 14, 24, 68	12 ea
36867	12" Flagged Duo-Sweep Angle Broom – (Head Only)	5.5" - 7"	00, 01, 02, 04, 05, 09, 14, 24	12 ea
Unflagged Duo-Sweep Angle Brooms				
36885	12" Unflagged Duo-Sweep Heavy Duty Angle Broom with 48" Metal Handle	5.5" - 7"	00	12 ea
41083	12" Unflagged Duo-Sweep Broom with 48" Fiberglass Handle	5.5" - 7"	01, 02, 04, 05, 09, 14, 24, 68	12 ea
36868	12" Unflagged Duo-Sweep 12" Angle Broom (Head Only)	5.5" - 7"	01, 02, 03, 04, 05, 09, 14	12 ea
Replacement Handles				
41225	48" Fiberglass Handle with Self-Locking Flex™ Tip – 1" D	—	00*, 01, 03, 04, 05, 09, 14	12 ea
3620294	48" Plastic Coated Metal Threaded Handle – 15/16" D	—	03	12 ea
3620194	48" Powder Coated Metal Threaded Handle – 7/8" D	—	14	12ea
Recycled Angle Broom				
40650	12" Flagged Recycled Angle Broom with 48" Steel Handle	6" - 7"	00	12 ea

DUSTPANS & SWEEPERS

Lobby Pan & Broom Combos

- Lobby pans and brooms with sectional handles to give you over 50% reduction in carton size; lower cube saves warehouse space and shipping costs
- The lobby pans pivot and lock into place during use and release for easy carrying or emptying
- Handles feature a pivoting hanging hole at top for storage

361415 Combo includes the following:

- Serrated edge allows you to comb the broom's bristles and drop debris into the pan
- Handy clip to attach broom for convenient storage
- 30" two-piece handle made from vinyl coated steel

361416 Combo includes the following:

- Adjustable position head for more functional use in corners and under counters or tables
- 3 piece, 30" handle
- Handy clip to attach broom for convenient storage
- Shelf-friendly packaging



Dust & Lobby Pans

- Dust Pans are available in metal or plastic as well as in a "flip-up" lobby style or hand held
- Dust pan (361437) features a 90° threaded handle hole to convert it to an economy lobby dustpan
- 361420 features a 2 piece handle which reduces the carton size, saving warehouse space and shipping costs
- 361420 has plastic edged teeth on the bail which allows you to comb through broom bristles to remove debris



Black(03)

Prod No	Description	Material	Style	Color	Pack
Lobby Pan & Broom Combos					
361415	Duo-Pan™ Lobby Pan & Duo-Sweep Broom Combo	Plastic	Lobby	03	1 ea
361412	Broom Handle Clip for 361415	—	—	03	12 ea
361416	Duo-Pan™ II Lobby Pan & Broom Combo	Plastic	Lobby	03	4 ea
Dust & Lobby Pans					
361420	12" Wide Lobby Dust Pan with 2-Piece 30" Handle	—	Lobby	03	1 ea
361410	12" Duo-Pan™ Plastic Lobby Pan with 30" Metal Handle	Plastic	Lobby	03	6 ea

FLOOR SQUEEGEES

One-Piece Rubber Squeegee with Plastic Frame

- All plastic construction will not rust or bend and helps prevent hazard sparks when cleaning-up flammable fluids
- Available in colors to support HACCP compliance
- For smooth surfaces



Double Foam Squeegees with Metal Frame

- Rugged black neoprene for heavy-duty removal of dirt, water and debris on uneven surfaces
- Medium flexibility and non-marking



Straight Rubber Squeegee with Metal Frame

- Durable construction
- Non-marking single red gum rubber blade with medium flexibility
- Heavy duty steel frame with red powder coating



Double Moss Foam Rubber Squeegee with Plastic Frame

- Soft, double foam is fat and oil resistant
- All plastic construction will not rust or bend and helps prevent hazard sparks when cleaning-up flammable fluids
- For uneven or smooth surfaces



Recommended handle sold separately on page 246

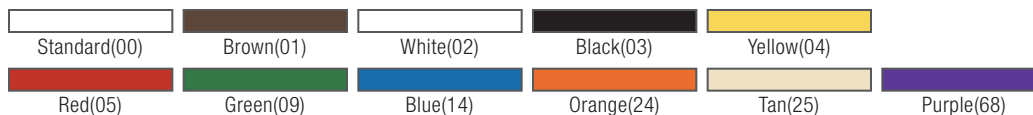

Prod No	Description	Handle	Color	Pack
One-Piece Rubber Squeegee with Plastic Frame				
36567	20" Solid, One-Piece Rubber Squeegee	Threaded	01, 02, 03, 04, 05, 09, 14, 24, 25, 68	6 ea
36568	24" Solid, One-Piece Rubber Squeegee	Threaded	01, 02, 03, 04, 05, 09, 14, 24, 68	6 ea
Double Foam Squeegees with Metal Frame				
40081	18" Double Foam Neoprene Rubber	1.13" Tapered	00	6 ea
40082	24" Double Foam Neoprene Rubber	1.13" Tapered	00	6 ea
40083	30" Double Foam Neoprene Rubber	1.13" Tapered	00	6 ea
Single Straight Rubber Squeegee with Metal Frame				
40076	24" Straight Red Gum Squeegee	1.13" Tapered	00	6 ea
Double Moss Foam Rubber Squeegee with Plastic Frame				
366918	18" Red Foam Rubber	.94" Threaded	00	10 ea
366922	22" Red Foam Rubber	.94" Threaded	00	10 ea

HANDLES

Color-Coded Fiberglass Handles

- Durable for heavy usage
- For use with push brooms, sweeps, squeegees and floor scrubs
- Self-Locking Flex-Tip Handle offers greater flexibility and reduces handle stress
- See the foodservice catalog for a complete listing of handle options

Wood Handles

- Made of lacquered hardwood
- Economical choice

FIBERGLASS



WOOD



FLOOR & RESTROOM MAINTENANCE

Drain Opener

- Convenient, sanitary way to remove floor drain covers
- One-piece construction with plastic handles for secure grip



40146

Floor Drain Brush

- Long lasting polypropylene bristles and plastic handles stand up to rugged use
- Drain Brush handles (sold separately) are prominently marked in English and Spanish for "floor drain use only" to prevent contact with food and serving utensils
- Available in a variety of sizes

40144

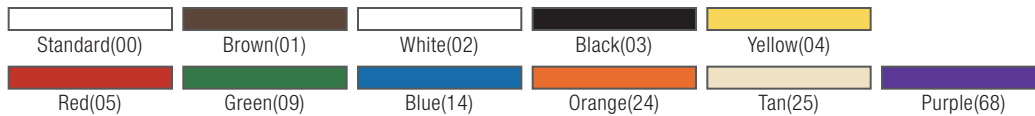

Prod No	Description	Dia	Style	Color	Pack
---------	-------------	-----	-------	-------	------

Color-Coded Fiberglass Handles

40225	60" Fiberglass Handle with Self-Locking Flex-Tip	1"	Threaded	01, 02, 03, 04, 05, 09, 14, 24, 25, 68	12 ea
-------	--	----	----------	--	-------

Tapered Handles

40261	54" Wood Handle	1.13"	Tapered	00	12 ea
-------	-----------------	-------	---------	----	-------

Prod No	Description	Color	Pack
---------	-------------	-------	------

Drain Opener

40144	Drain Opener	02	12 ea
-------	--------------	----	-------

Floor Drain Brush

40146	3" Floor Drain Brush	00	6 ea
40147	4" Floor Drain Brush	00	6 ea
41093	5" Floor Drain Brush	00	6 ea
40148	6" Floor Drain Brush	00	6 ea
40236	36" Plastic Drain Brush Handle	00	12 ea
40237	48" Plastic Drain Brush Handle	00	12 ea

LOOPED END MOPS

Synthetic/Cotton Blend Looped-End

- Maximum Durability
- 50-75 uses per mop
- S, M and L are available in brick packs

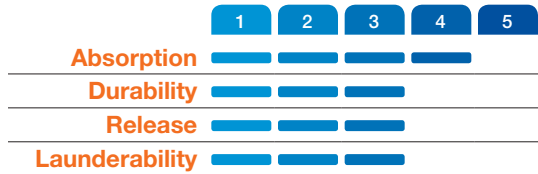

4 Ply Cotton Looped-End

- All purpose for general cleaning
- Packaged in brick packs

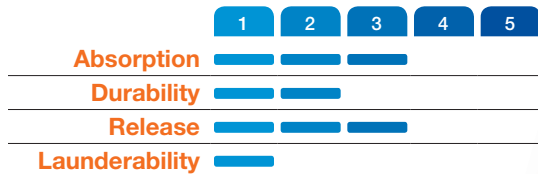

Recommended handles sold on page 240



Prod No	Description	Handle	Color	Pack
Synthetic/Cotton Blend (Wide Band)				
369412B	Small Yellow Wide Band Mop with White Yarn	Jaw Style	00	12 ea
369442B	Small Yellow Wide Band Mop with Blue Yarn	Jaw Style	14	12 ea
369472B	Small Yellow Wide Band Mop with Green Yarn	Jaw Style	09	12 ea
369418B	Medium Green Wide Band Mop with White Yarn	Jaw Style	00	12 ea
369448B	Medium Green Wide Band Mop with Blue Yarn	Jaw Style	14	12 ea
369478B	Medium Green Wide Band Mop with Green Yarn	Jaw Style	09	12 ea
369424B	Large Red Wide Band Mop with White Yarn	Jaw Style	00	12 ea
369454B	Large Red Wide Band Mop with Blue Yarn	Jaw Style	14	12 ea
369484B	Large Red Wide Band Mop with Green Yarn	Jaw Style	09	12 ea
369430	X-Large Blue Wide Band Mop with White Yarn	Jaw Style	00	12 ea
369460	X-Large Blue Wide Band Mop with Blue Yarn	Jaw Style	14	12 ea
4-Ply Cotton (Wide Band)				
369550B	Small Yellow Band Looped-End Mop	Jaw Style	00*	12 ea
369551B	Medium Green Band Looped-End Mop	Jaw Style	00*	12 ea
369552B	Large Red Band Looped-End Mop	Jaw Style	00*	12 ea
4 Ply Cotton (Narrow Band)				
369413B	Small Yellow Band Looped-End Mop	Quick Release/Quick Change	00*	12 ea
369419B	Medium Green Band Looped-End Mop	Quick Release/Quick Change	00*	12 ea
369425B	Large Red Band Looped-End Mop	Quick Release/Quick Change	00*	12 ea

LOOPED END & CUT END MOPS

Microfiber Looped-End

- Microfiber mop combines the absorbency and durability of microfiber with conventional mop design and functionality
- Washable mop dries quickly and is still effective with 500 washings
- Visit the foodservice catalog for a complete list of microfiber products

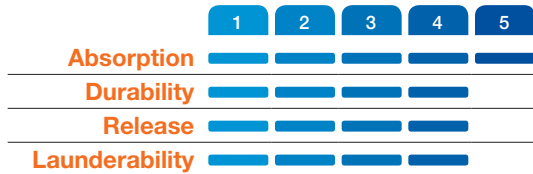

Rough Surface Looped-End

- 17 oz knitted fleece provides twice the absorbency of cotton yarn mops
- Excellent for abrasive surfaces: stone, quarry, tile and concrete

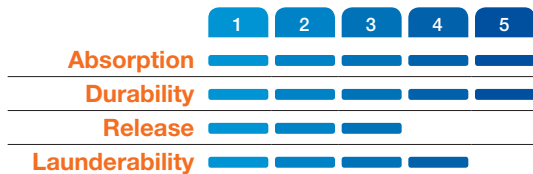

Rayon Blend Finishing Looped-End

- Durable 4-ply rayon blend has narrow band
- Releases liquid faster than a conventional mop for a smoother finish
- Brick packed

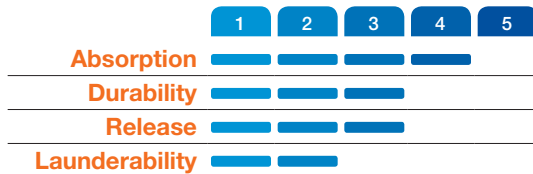

Recommended handles sold on page 240



Prod No	Description	Handle	Color	Pack
Microfiber (Wide Band)				
369420	Medium Loop End Microfiber Mop	Jaw Style	02, 14	12 ea
Rough Surface (Narrow Band)				
369320	Medium Looped-End Rough Surface Mop	Quick Release/Quick Change	00	12 ea
4 Ply Rayon Blend Finishing (Wide Band)				
369670B	#20 Medium Finishing Looped-End Mop	Quick Release/Quick Change	14	12 ea
369674B	#24 Large Finishing Looped-End Mop	Quick Release/Quick Change	14	12 ea

4 Ply Cotton Cut-End

- Economical choice for general mopping
- Brick packed

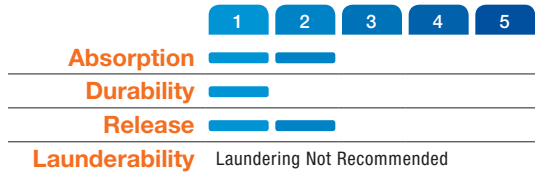

8 Ply Cotton Cut-End

- Abrasion-resistant, long lasting 8 ply cotton
- Best for general purpose cleaning

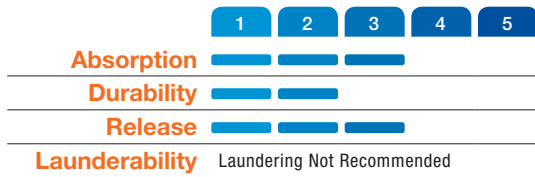

Recommended handles sold on page 240

Standard(00)

Prod No	Description	Handle	Color	Pack
4 Ply Cotton (Narrow Band)				
369816B	#16 Small Cut-End Mop	Quick Release/Quick Change	00	12 ea
369820B	#20 Medium Cut-End Mop	Quick Release/Quick Change	00	12 ea
369824B	#24 Large Cut-End Mop	Quick Release/Quick Change	00	12 ea
369832	#32 X-Large Cut-End Mop	Quick Release/Quick Change	00	12 ea
4 Ply Cotton (Wide Band)				
369811B	#16 Small Cut-End Mop	Jaw Style	00	12 ea
369814B	#20 Medium Cut-End Mop	Jaw Style	00	12 ea
369817B	#24 Large Cut-End Mop	Jaw Style	00	12 ea
369819B	#32 X-Large Cut-End Mop	Jaw Style	00	12 ea
8-Ply Cotton (Narrow Band)				
369724	#24 Select Cut-End Mop	Quick Release/Quick Change	00	12 ea
369732	#32 Select Cut-End Mop	Quick Release/Quick Change	00	12 ea

CUT END MOPS

4 Ply Rayon Cut End

- Easy to change mop heads lie flat for more efficient mopping

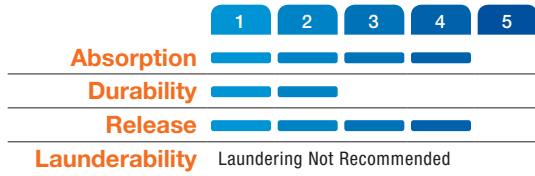

MOP HANDLES

- Mop handles available in a variety of styles including Jaw Style, Quick-Release, and Quick Change
- Visit carlislefsp.com for a complete listing of product features

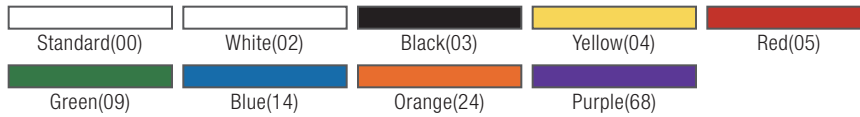

Prod No	Description	Handle	Color	Pack
4-Ply Rayon (Narrow Band)				
369066B	#16 Small Cut-End Mop	Quick Release/Quick Change	00	12 ea
369070B	#20 Medium Cut-End Mop	Quick Release/Quick Change	00	12 ea
369074B	#24 Large Cut-End Mop	Quick Release/Quick Change	00	12 ea
369082	#32 X-Large Cut-End Mop	Quick Release/Quick Change	00	12 ea
Prod No	Description	Dia	Color	Pack
Jaw Style Mop Handles				
369475	60" Fiberglass Mop Handle	1"	00, 02, 03, 04, 05, 09, 24, 68	12 ea
36970	60" Vinyl Coated Metal Mop Handle	.94"	00	12 ea
Color-Coded Quik-Release Mop Handle				
41664	60" Fiberglass Mop Handle	1"	02, 04, 05, 09, 14, 24, 68	12 ea
Quik-Release Handle				
369595	Quik-Release Powder-Coated Metal Handle	—	00	12 ea
Quick Change Handles – Wood				
369365	60" Wood Mop Handle with Plastic Head	1.13"	00	12 ea
40340	63" Wood Mop Handle with Metal Head	1.13"	00	12 ea
Quick Change Handle – Fiberglass				
369375	60" Fiberglass Mop Handle with Plastic Head	1"	00	12 ea
Quick Change Handle – Vinyl Coated Metal				
36968	60" Handle with Plastic Head	1"	00	12 ea

MOP BUCKETS & SIGNS

Bucket & Wringer Combos

- Made of durable, corrosion resistant polyethylene
- Non-marking casters
- Available in 26 or 35 quart sizes
- Individual Side Press Wringer available – fits both 26 quart (36908) and 35 quart (36904) mop buckets



36904



36908W



36905



36908

Wet Floor Signs

- Durable polypropylene
- Specially designed feet protect floor finishes
- 36900 locks into place to prevent collapsing
- Compact for easy storage



36909



36900

Freestanding Caution Cones

- 360° visibility
- Caution message appears in English, Spanish and French



36941



36942

Case for 36942 Pop Up Caution Cone



Caution Pop Up Cones

- 360° visibility
- Caution message appears in English, Spanish and French
- Case can be mounted to wall for easy access



Prod No	Description	Color	Pack
Mop Buckets			
36908	26 qt Bucket with Side Press Wringer	04, 05, 09, 14, 69	1 ea
36904	35 qt Bucket with Side Press Wringer	04, 05, 09, 14, 69	1 ea
36908W	Side Press Wringer for 26 qt and 35 qt Mop Bucket	04, 05, 09, 14, 69	1 ea
36905	35 qt Bucket with Down Press Wringer	04	1 ea
36908C	3" Swivel Casters for all Mop Buckets	00	2 ea
Folding Wet Floor Signs			
36900	Floor Sign (English/Spanish)	00	6 ea
36909	Economy Wet Floor Sign (English/Spanish/German)	04	6 ea
Caution Cones			
36941	36" Caution Cone	04	3 ea
36942	20" Pop Up Caution Cone	04	12 ea



CARLISLE
FOODSERVICE PRODUCTS

PROFESSIONAL
DURABLE
TOUGH
HARD-
WORKING
**TRANS-
PORTATION
& WASTE
MANAGEMENT**

Carlisle's high quality dollies, carts and caddies help you reduce the risk of food contamination and employee injuries.



Items in this section are purchased through Carlisle FoodService Products and will ship separately from Dinex orders. Please contact your local sales representative for more information.



CARTS

Our **unique combination** of space saving design, load capacity and long-lasting durability provide **superior value** and make Fold 'N Go the transport cart every foodservice operation needs.

Perfect for full kitchens, hallways or off-site catering; Fold 'N Go Carts **support 350 pounds** and fold up in a single, quick and easy motion. The cart **ships fully assembled** making ownership a joy from the very beginning.

Fold 'N Go® Carts

- Folds up to store easily behind doors, between counters or in small spaces
- Solid legs and sturdy shelves hold up to 350 pounds
- Cart ships fully assembled; no tools or complicated latches required
- Collapses to 9" width and 10.5" width; stores easily behind doors, in between counters or back of delivery vans
- Folds down, tucks away and is always available for multiple purposes
- Shelves are easy to clean; top shelf has ergonomically shaped, easy grip handles at both ends for a fast, secure grip
- 4" heavy-duty, non-marking swivel casters with molded-in metal reinforcement plates are permanently staked to .75" solid aluminum legs for longer life and added strength and rigidity



SBC1521

SBC2031



350 lb Capacity



Easily folds with one hand

Find replacement parts at www.carlislefsp.com/replacement-parts



Bussing Carts

- Durable construction stands up to the toughest use
- Shelves are textured to minimize scratches and provide a better grip
- Convenient knockdown design is easy to assemble
- Available with optional back panels to hide clutter or locking doors to secure sensitive items like liquor or cleaning supplies (15" x 21" size only)



CC2036DP, available with locking doors and side panels to secure sensitive items



Trash container and silverware holder sold separately

Raised edges on shelves help keep contents secure during transport

Side panels help hide clutter

Durable construction will stand up to the toughest use



Prod No	Description	Weight Capacity	Color	Pack
Fold 'N Go Carts				
SBC1521	15" x 21" Fold 'N Go Cart	350 lb	03, 23	1 ea
SBC2031	20" x 31" Fold 'N Go Cart	350 lb	03, 23	1 ea
SBCC240	Fold 'N Go Cart Replacement Caster, Swivel	—	00	1 ea
SBCC245	Fold 'N Go Cart Replacement Caster, Swivel with Brake	—	00	1 ea
SBCA30000	Fold 'N Go Cart Replacement Slide Bracket Assembly	—	—	1 ea
SBCRKIT	Fold 'N Go Hardware Replacement Kit (includes 2 casters)	—	—	1 ea
Bussing Carts				
CC2243 Δ	42" x 23" Large Bussing Cart	300 lb	03	1 ea
CC2036 Δ	18" x 36" Bussing Cart	300 lb	03	1 ea
CC2036DP	18" x 36" Bussing Cart with Doors and Back Panels	300 lb	03	1 ea
CC2036P	18" x 36" Bussing Cart with Back Panels	300 lb	03	1 set
CD2036	18" x 36" Doors and Back Panels Only	—	03	1 set
CP2036	18" x 36" Back Panels Only	—	03	1 set
CC11SH ♦	Accessory Bin for Bussing Cart	—	03	1 ea
CC11TH	Trash Bin for Bussing Cart	—	03	1 ea

NSF Listed products are designated with a **Δ** and may be prefixed with an N
 Shipping Notes: CC2036 & SBC1521 can ship UPS/FedEx Ground at
 oversize cost, CC2243 & SBC2031 cannot ship UPS/FedEx Ground
 ♦ California Residents: Bisphenol A **WARNING:** See appendix A on page 281



CARTS

Stainless Steel Utility Carts

- Utility carts are constructed of heavy gauge stainless steel for superior strength and durability
- Continuous weld construction provides added durability as compared to other, spot welded utility carts
- Non-marking soft rubber bumpers prevent scratches and scuffs on walls



UC4031529



UC3031524



UC7022133

Service Cart

- One-piece design, all plastic construction
- Polyethylene exterior and polyurethane foam core for added strength
- Heavy-duty 5" non-marking caster with molded-in metal reinforcement plates
- Optional Trash Container (SBC11TC) and Part Holder (SBC11SH) available separately
- NSF Listed



SBC230 with SBC11TC and SBC11SH



Find replacement parts at www.carlislefsp.com/replacement-parts

Black(03)

Prod No	Description	Weight Capacity	Color	Pack
Service Cart				
SBC230 Δ	Service Cart - 2 Fixed Casters, 2 Swivel Casters, 1 with Brake	500 lb	03	1 ea
SBC11SH	Part Holder for SBC230	—	03	1 ea
SBC11TC	Trash Container for SBC230	—	03	1 ea
Stainless Steel Utility Carts				
UC3031524	15.5" x 24", 3 Shelf Utility Cart	300 lb	—	1 ea
UC3031827	18" x 27", 3 Shelf Utility Cart	300 lb	—	1 ea
UC5031524	15.5" x 24", 3 Shelf Utility Cart	500 lb	—	1 ea
UC5031827	18" x 27", 3 Shelf Utility Cart	500 lb	—	1 ea
UC5032135	21" x 35", 3 Shelf Utility Cart	500 lb	—	1 ea
UC7022133	21" x 33", 2 Shelf Utility Cart	700 lb	—	1 ea
UC7032133	21" x 33", 3 Shelf Utility Cart	700 lb	—	1 ea
UC4031529	15.75" x 29.5", 3 Shelf Knock-Down Utility Cart	400 lb	—	1 ea
UC4031733	17.75" x 33.38", 3 Shelf Knock-Down Utility Cart	400 lb	—	1 ea

NSF Listed products are designated with a Δ and may be prefixed with an N

Shipping Notes: SBC230, UC3031524, UC3031827, UC5031524, UC5031827, UC5032135, UC7031524, UC7031827, UC7022133, UC7032133 cannot ship UPS/FedEx



Utility Carts

- Excellent for transporting equipment and heavy loads
- Bin top utility carts (UC4018 & UC4525) reduce the potential for items to fall off during transport
- Durable and chemical-resistant polypropylene construction; will not rust, dent, chip, or peel
- Convenient knock-down design
- Integrated cord wrap for easy access (UC1940)



UC4018



UC1940

Find replacement parts at
www.carlislefsp.com/replacement-parts



Prod No	Description	Weight Capacity	Color	Pack
Utility Carts				
UC1940	19" x 40" x 32.5" Utility Cart	500 lb	23	1 ea
UC4018	40" x 17.25" Small Bin Top Utility Cart	500 lb	23	1 ea
UC4525	45" x 25" Large Bin Top Utility Cart	500 lb	23	1 ea
UCC4018	Replacement Casters for UC4018 & UC4525 (Swivel, 2 pack)	—	00	1 cs
UCC4525	Replacement Casters for UC4018 & UC4525 (Fixed, 2 pack)	—	00	1 cs



WASTE CONTAINERS & LIDS

When it comes to **waste and material handling**, you can count on Carlisle to deliver products designed for **heavy duty usage**.

Bronco™

- Heavy-duty construction with double-reinforced stress ribs; drag skids for durability
- Comfort Curve™ handles provide easy handling
- Helper handles on base for controlled tipping or overhead lifting
- Reinforced lids have snap down tab locks with a simple press & pull release system for easy removal
- NSF Std 21 – meets the criteria for thermoplastic refuse containers
- NSF Std 2 – meets the criteria for food contact and cleanability

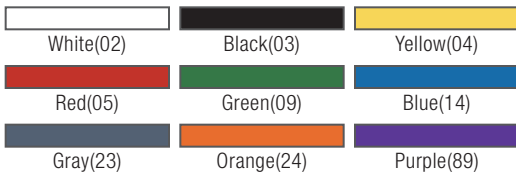

Built-In Durability

Prod No	Description	Color	Pack
Bronco Round Waste Containers & Lids			
341010 Δ	10 gal Waste Container, 16.13" x 17"	02, 03, 04, 05, 09, 14, 23, 24, 89*	6 ea
341011 Δ	10 gal Lid, 16.13" x 2"	02, 03, 04, 05, 09, 14, 23, 24, 89	6 ea
341020 Δ	20 gal Waste Container, 20" x 23"	02, 03, 04, 05, 09, 14, 23, 24, 89*	6 ea
341021 Δ	20 gal Lid, 20" x 2.13"	02, 03, 04, 05, 09, 14, 23, 24, 89*	6 ea
341032 Δ	32 gal Waste Container, 22.38" x 27.75"	02, 03, 04, 05, 09, 14, 23, 24, 89	4 ea
341033 Δ	32 gal Lid, 24" x 2.13"	02, 03, 04, 05, 09, 14, 23, 24, 89	4 ea
341034	32 gal Dome Lid	03	1 ea
341035	32 gal Funnel Lid	03	4 ea
341044 Δ	44 gal Waste Container, 26.88" x 31.38"	02, 03, 04, 05, 09, 14, 23, 24, 89	3 ea
341045 Δ	44 gal Lid 26.88" x 2.25"	02, 03, 04, 05, 09, 14, 23, 24, 89	3 ea
341055 Δ	55 gal Waste Container, 26.5" x 33"	02, 03, 04, 05, 09, 14, 23, 89*	2 ea
341056 Δ	55 gal Lid, 26.5" x 2.25"	02, 03, 04, 05, 09, 14, 23, 89*	2 ea
341057	44/55 gal Dome Lid	03	1 ea
341132 Δ	32 gal Container with Dolly, 22.38" x 38.25"	02, 04, 05, 09, 14, 23	4 ea
341144 Δ	44 gal Container with Dolly, 26.88" x 37.75"	02, 04, 05, 09, 14, 23	3 ea

NSF Listed products are designated with a Δ and may be prefixed with an N

*Color available by special order only



Carlisle Dollies

- Dollies fit our 20, 32, 44 and 55 gallon containers for safe transport of heavy loads
- Simple twist-to-lock feature securely attaches dolly to containers
- Dollies include standard Carlisle non-marking 3" swivel casters
- NSF Std 2—meets the criteria for food contact and cleanability



TrimLine™

- Designed for narrow spaces
- Self-venting for easier bag removal
- Corner tabs keep bag in place
- Helper handle on bottom makes lifting and dumping easier



342023
369210



TOP SELLER

342024

342023

342025



Helper Handle



Corner Tab



342015



369210

TrimLine™ Dolly

- Efficient transport reduces transportation time
- Low profile design allows dolly and container to fit under standard foodservice counters
- For use with 15 or 23 gallon size TrimLine container or similar competitor slim-style trash cans
- 200 lb weight capacity



Prod No	Description	Color	Pack
Carlisle Dollies			
36911 Δ	Standard Round Container Dolly, 17.75" x 6"	03	2 ea
36910 Δ	Round Container Dolly with Replaceable Casters	03	2 ea
3672231	3" Replacement Caster for 36910 Dolly	—	1 ea
TrimLine Containers			
342015	15 gal TrimLine Container	23	4 ea
342023	23 gal TrimLine Container	03, 06, 09, 14, 23, 69	4 ea
342024	TrimLine Swing Top Lid, 20.13" x 11.5" x 4.5"	03, 06, 23, 69	4 ea
342025	TrimLine Handled Lid, 20.5" x 11.5" x 3"	03	4 ea
369210	TrimLine Dolly	03	1 ea

NSF Listed products are designated with a Δ and may be prefixed with an N



THE
SOUVERS
(KICKASSING FOOD)

 **san jamar**[®]
smart. safe. sanitary.

SMART SAFE SANITARY SAN JAMAR

At San Jamar, our innovative new ideas for food safety, counter service, personal safety, bar and food management and washroom products come directly from insights we gain from our customers. That's why we work alongside our customers in every facet of their operations. We listen to their challenges, identify potential problems and look for the small changes that could make big improvements in safety and efficiency. Finally, we respond with ground-breaking new products that make their operations smarter, safer and more sanitary. Then, when we're finished, we go back and start all over again.





CUTTING BOARDS

Patented food safety hook allows for sanitary transport & storage. **Integrated Ruler** makes portioning easy, eliminating guess-work and saving money.

Saf-T-Grip® Cutting Boards

- Integrated anti-slip grips securely hold board in place
- Reduce cross-contamination with color-coded cutting boards
- Durable co-polymer construction provides superior heat, chemical and warp resistance
- Material won't dull knives and resists unsanitary cut-grooving



Cut-N-Carry® Cutting Boards

- Reduce cross-contamination with color-coded cutting boards
- Durable co-polymer construction provides superior heat, chemical and warp resistance
- Material won't dull knives and resists unsanitary cut-grooving



Black(BK)	Blue(BL)	Brown(BR)	Green(GN)	Red(RD)	Yellow(YL)	White (WH)
Prod No	Color	H x W x D		Pack		
Saf-T-Grip Cutting Boards						
CBG912* Δ	BL, BR, GN, RD, WH, YL	9" x 12" x 0.38" (229 x 305 x 9.5 mm)		1 ea		
CBG121812* Δ	BL, BR, GN, RD, WH, YL	12" x 18" x 0.5" (305 x 457 x 13 mm)		1 ea		
CBG152012* Δ	BL, BR, GN, RD, WH, YL	15" x 20" x 0.5" (381 x 508 x 13 mm)		1 ea		
CBG182412* Δ	BL, BR, GN, RD, WH, YL	18" x 24" x 0.5" (457 x 610 x 13 mm)		1 ea		
CBGW912* Δ	BL, GN, RD, YL	9" x 12" x 0.38" (229 x 305 x 9.5 mm)		1 ea		
CBGW152012* Δ	BL, GN, RD, YL	15" x 20" x 0.5" (381 x 508 x 13 mm)		1 ea		
Cut-N-Carry Cutting Boards						
CB101212* Δ	GN, YL	10" x 12" x 0.5" (254 x 305 x 13 mm)		1 ea		
CB121812* Δ	BL, BR, GN, RD, YL	12" x 18" x 0.5" (305 x 457 x 13 mm)		1 ea		
CB152012* Δ	BL, BR, GN, RD, YL	15" x 20" x 0.5" (381 x 508 x 13 mm)		1 ea		
CB182412* Δ	BL, BR, GN, RD, YL	18" x 24" x 0.5" (457 x 610 x 13 mm)		1 ea		
CB121834* Δ	BL, BR, GN, RD, YL	12" x 18" x 0.75" (305 x 457 x 19 mm)		1 ea		
CB182434* Δ	BL, BR, GN, RD, YL	18" x 24" x 0.75" (457 x 610 x 19 mm)		1 ea		
CB121812WH Δ	WH	12" x 18" x 0.5" (305 x 457 x 13 mm)		1 ea		
CB152012WH Δ	WH	15" x 20" x 0.5" (381 x 508 x 13 mm)		1 ea		
CB182412WH Δ	WH	18" x 24" x 0.5" (457 x 610 x 13 mm)		1 ea		

NSF Listed products are designated with a Δ

*Specify desired color after item number. Example: CBG912GN

SAFE FOOD PREP

CBM1622

Place Saf-T-Grip Board-Mate under cutting boards to **minimize dangerous board slips and injuries**. The non-porous material **securely holds cutting boards in place and minimizes cross-contamination**.

Saf-T-Grip® Board Mate®

- Replace unsanitary “wet towel” method to keep non-grip from sliding
- Reduce knife accidents
- Dishwasher safe



CBM1318

CBM1016

Allergen Saf-T-Zone™ System & Mats

- Purple color alerts staff to follow special food allergy procedures
- Durable purple case is easy to find in the kitchen and securely protects tools
- Purple color allergen mats alert staff to follow special food allergy procedures
- Top 8 allergens are identified on the mat and cutting board to aid in allergen awareness



ASZ121812SYS



Allergen Saf-T-Zone Cutting Board CBG121812PR

10" Chef Knife ASZKNIFE

12" Tongs ASZTONGS

13" Turner ASZTURNER



CBMASZ1212

Prod No	H x W	Pack
Saf-T-Grip Board Mate		
CBM1016 Δ ♦	10" x 16" (254 x 406 mm)	1 ea
CBM1318 Δ ♦	13" x 18" (330 x 457 mm)	1 ea
CBM1622 Δ ♦	16" x 22" (406 x 559 mm)	1 ea

Prod No	Description	Pack
Allergen Saf-T-Zone System		
ASZ121812SYS Δ	(1) Saf-T-Grip Purple Cutting Board 12" X 18" X 0.5" (1) Stainless Steel Chef Knife With Purple Handle 10" (1) Stainless Steel Tongs With Purple Handle 12" (1) Stainless Steel Turner With Purple Handle 13"	1 ea
CBMASZ2430 Δ ♦	Prep station mat 24"x 30" (304 x 304 mm)	1 ea
CBMASZ1212 Δ ♦	Server window mat 12" x 12" (609 x 609 mm)	1 ea

NSF Listed products are designated with a Δ

♦ California Residents: Styrene **WARNING:** See appendix C on page 281



SAFE FOOD PREP

Provides **safe, sanitary and secure storage** for kitchen knives. The see-through closed container **protects** knives from contaminants while **allowing staff to view knives**, making choosing the correct knife easy. The **3-piece break-resistant plastic** construction is easy to assemble, mount and disassemble for cleaning.

Saf-T-Knife® Station

- Top slot configuration includes space for up to 8 knives, even a cleaver, and a knife sharpener
- Easy to disassemble and clean
- Dishwasher safe



STK1008
*Knives not included

Saf-T-Knife® Station Jr.

- Top slot configuration includes two large slots that can accommodate a variety of knife sizes
- Color-coded lids designed to keep track of which knife is used for what purpose
- Easy to disassemble and clean
- Dishwasher safe



STK1006RDL



STK1006YLL



STK1006GRL



STK1006PRL



STK1006
*Knives not included

Prod No	Description	H x W x D	Pack
Saf-T-Knife Stations			
STK1008 Δ	Saf-T-Knife Station	15" x 15" x 4.25" (381 x 381 x 108 mm)	1 ea
STK1006 Δ	Saf-T-Knife Station Jr.	14.5" x 8.3" x 4" (368 x 211 x 102 mm)	1 ea
STK1006RDL Δ	Red lid for Saf-T-Knife Station Jr.	1.86" x 8" x 4" (48 x 203 x 102 mm)	1 ea
STK1006GRL Δ	Green lid for Saf-T-Knife Station Jr.	1.86" x 8" x 4" (48 x 203 x 102 mm)	1 ea
STK1006YLL Δ	Yellow lid for Saf-T-Knife Station Jr.	1.86" x 8" x 4" (48 x 203 x 102 mm)	1 ea
STK1006PRL Δ	Purple lid for Saf-T-Knife Station Jr.	1.86" x 8" x 4" (48 x 203 x 102 mm)	1 ea

NSF Listed products are designated with a Δ



Drastically reduce the footprint of your wrapping station with Saf-T-Wrap 12 and 18.

Saf-T-Wrap® 12 & 18

- Accommodates film or foil rolls and saves time while minimizing waste
- Includes both safety blade for flim, foil or paper – or slide cutting for one-handed film dispensing
- Film and foil rolls are fully enclosed preventing cross-contamination from unsanitary cardboard cutter boxes



Prod No	Description	Capacity	Pack
Saf-T-Wrap 12 & 18			
SW12 Δ	Saf-T-Wrap with slide cutter and optional safety blade (for film or foil)	Dispense film/foil rolls from 12" (305 mm)	1 ea
SW18 Δ	Saf-T-Wrap with slide cutter and optional safety blade (for film or foil)	Dispense film/foil rolls from 15"-18" (381-457 mm)	1 ea
SWX100 Δ	Saf-T-Wrap Stackers (2) brackets (8) wing nuts	Stacker brackets, holds 2 dispensers	1 ea

NSF Listed products are designated with a Δ



SAFE ICE HANDLING

Protect ice from dangerous contamination. Features an integrated comfort handle with raised Tri-grips™ to prevent hand contamination and for easy and safe pouring at any level.

Original & Shorty™ Saf-T-Ice® Tote

- Dedicated container for safe ice transport
- Use Original Saf-T-Ice Tote for high capacity carrying and manual cleaning
- Use Shorty Saf-T-Ice Totes for dish machine washing and smaller ice load capacity
- HACCP Hanger™ reduces back strain and injuries and attached to ice machines for faster, more efficient filling of ice totes
- Tri-grip design for easier, more controlled handling



SI6100

SI6000



Saf-T-Ice® Cart

- Cart transport system for use with up to two Saf-T-Ice Totes
- Avoid costly work injuries; doubles productivity
- Folds for easy storage



SICART60

Prod No	Description	Capacity	Pack
Saf-T-Ice Totes & Carts			
SI6000 Δ ♦	Original Saf-T-Ice Tote	6 gallons (22.7 L)	1 ea
SI6100 Δ ♦	Shorty Saf-T-Ice Tote	5 gallons (18.9 L)	1 ea
SICART60 Δ	Saf-T-Ice Cart for Original Tote	(2) SI6000 Totes	1 ea
SICART61 Δ	Saf-T-Ice Cart for Shorty Tote	(2) SI6100 Totes	1 ea

NSF Listed products are designated with a Δ

♦ California Residents: Bisphenol A **WARNING:** See appendix A on page 281



Rapi-Kool Plus Cold Paddles from San Jamar are a versatile and efficient way to **quickly and safely cool** soups, stews and other hot liquids. Help chill foods from the inside-out, **minimizing time-temperature abuse** and bacterial growth with Rapi-Kool Plus Cold Paddles.

Rapi-Kool® Plus Cold Paddles

- Wide opening allows for on-demand use by filling with ice and water
- Patented Fill-Rite™ design eliminates over-filling when pre-freezing
- Integrated hanging hook for sanitary and secure storage



Protect ice from dangerous contact with knuckles and thumbs while scooping and serving, with the **Saf-T-Scoop & Guardian System**. The **Guardian holder** provides dedicated safe and **sanitary storage** for Saf-T-Scoop when not in use.

Saf-T-Scoop® & Guardian™

- Available in sizes designed for bar and beverage stations, as well as back-of-house ice bins
- Germ-Guards™ protect ice from contact with hands
- Guardian, part of San Jamar's Safe Ice Handling System, provides safe, dedicated scoop storage
- Flexible mounting options



Prod No	Capacity	Pack
Rapi-Kool Plus Cold Paddles		
RCU64V2 Δ ♦	64 oz. (1.9 L)	1 ea
RCU128V2 Δ ♦	128 oz. (3.8 L)	1 ea
Saf-T-Scoop & Guardian		
Included Mounting Tools: (1) Mounting Bracket, (2) Wire Hanging Brackets and (2) Suction Cups		
SI5000 Δ ♦	6-10 oz. (177-295 ml)	1 ea
SI7000 Δ ♦	12-16 oz. (355-473 ml)	1 ea
SI7700 Δ ♦	20-24 oz (591-710 ml)	1 ea
SI9000 Δ ♦	64-86 oz. (1.9-2.5 L)	1 ea

NSF Listed products are designated with a Δ

♦ California Residents: Bisphenol A **WARNING:** See appendix A on page 281



SANITATION TOOLS

Kleen-Pail meets HACCP guidelines as dedicated-use, labeled containers for cleaning and sanitizing solutions.

Kleen-Pail® & Stands

- Color-coded pails for use with detergent and sanitizer
- Durable, robust handle design
- Trilingual design aids in training
- Stands allow you to move Sanitizer and Detergent Pails off of the floor or work surface



Saf-Check all-in-one system keeps your thermometer and sanitizer test strips together for easier, more frequent temperature and sanitizer strength checks.

Saf-Check®

- Combines thermometer and sanitizer test strips with easy-to-read Smart Scale™ guide
- Thumb wheel easily dispenses test strips
- Holds replaceable 15 ft. roll of chlorine or quaternary test strips



Prod No	Color	Description	Pack
Kleen-Pail & Stands			
KP97*	RD, GN	3 quart (2.84 L)	1 ea
KP196*	RD, GN, PR, KCBL, KCYL	6 quart (5.68 L)	1 ea
KP256*	RD, GN	8 quart (7.57 L)	1 ea
KP320*	RD, GN	10 quart (9.46 L)	1 ea
KPS196	Black	Kleen-Pail stand holds KP196	1 ea
KPS97	Black	Kleen-Pail stand holds KP97	1 ea
KPS196WM	Black	Kleen-Pail wall mount stand holds KP196	1 ea
KPS97WM	Black	Kleen-Pail wall mount stand holds KP97	1 ea
KP256WM	Black	Kleen-Pail wall mount stand holds KP256	1 ea

Prod No	Description	Pack
Saf-Check		
SFC1200CL Δ	Chlorine measure with thermometer	1 ea
SFC1200QT Δ	Quaternary measure with thermometer	1 ea
SFC1250CL Δ	Chlorine measure without thermometer	1 ea
SFC1250QT Δ	Quaternary measure without thermometer	1 ea
SFCROLLCL Δ	Replacement rolls - (2) chlorine 15 ft. rolls	1 ea
SFCROLLQT Δ	Replacement rolls - (2) quaternary 15 ft. rolls	1 ea

NSF Listed products are designated with a Δ

*Specify desired color after item number. Example: KP196PR

FOOD MANAGEMENT

The Dome features a patented, domed lid that rotates back for easy access and allows increased capacity when closed.

The Dome®, Mini Dome®, and Dome Stacker Garnish Centers

- Tailored to fit on standard mixing rails
- Available in a wide array of configurations with standard and deep trays
- Use standard size trays to keep food chilled with EZ-Chill™ re-freezable ice packs or deep trays for extra capacity
- Integrated snap-on caddies store straws, stirrers & picks
- Optional connectors provide modularity between Mini Dome and Dome



BD2001



BDS2203



BD4004

Insulated Food Carriers

- Maintain food quality and temperature during transport
- Insulated with 1" foam and lined with water repellent nylon
- Features outside identity pocket
- Comfortable padded handle
- Zipper closure



FC1212-RD



FC2212-RD



Prod No	Description	Capacity	Pack
Dome & Mini Dome Garnish Centers			
BD4003 Δ	(3) 2 qt. (1.9 L) deep trays; (2) handles	6 qt. (5.6 L)	1 ea
BD4004 Δ	(3) 3 pt. (2.9 L) deep trays; (2) handles	6 qt. (5.6 L)	1 ea
BD4014 Δ	(4) 1.5 pt. (0.71 L) standard trays; (2) handles	3 qt. (2.8 L)	1 ea
BD100S Δ	(2) snap-on caddies		1 set
BD2001 Δ	(1) 2 qt. (1.9 L) deep tray	2 qt. (1.9 L)	1 ea
BD2002 Δ	(1) 1 qt. (0.95 L) standard tray	1 qt. (0.95 L)	1 ea
BD2002CAR Δ	(1) 1 qt. (0.95 L) standard tray with caddy	1 qt. (0.95 L)	1 ea
BDS2203 Δ	Dome Stacker - 1/1 Mini Dome: (4) 1 pt. trays & bonus (2) 2 qt. trays	4 qt. (3.8 L)	1 ea
BDS2483NL Δ	Dome Stacker - 2/2 Mini Domes, (4) 1.5 pt. deep trays, (4) 1 pt. standard trays, (2) noyched lids & (2) standard lids	6 qt. (5.6 L)	1 ea
BDS4266 Δ	Dome Stacker - 1/1 Dome, (3) 2 qt. deep trays, (6) 1 pt. standard chillable trays	3 qt. (2.8 L)	1 ea

Prod No	H x W x D	Pack
Insulated Food Carriers		
FC1212-RD	12" x 12" x 12" (305 x 305 x 305 mm)	1 ea
FC2212-RD	12" x 22" x 12" (305 x 559 x 305 mm)	1 ea

NSF Listed products are designated with a Δ



SCALES

San Jamar's PRO MZR line of scales offer **precision and durability** met with a modern, user-friendly design and **unparalleled value.**

Round Professional Digital Scale

- Removable stainless steel platform
- Simple 2 button operation
- Tare feature and automatic shut off
- HACCP color-coded replacement platform available



SCDGP11RD



SCDGP11M



SCDGP11BK

Large Square Kitchen Scale

- Sealed display
- Tare feature
- Automatic shut-off



SCD613



Prod No	Color	Capacity	Increments	H x W x D	Adapter/Batteries	Pack
Round Professional Digital Scale						
SCDGP11* Δ	BK, RD, M	11 lb (5 kg)	0.1 oz (1 g)	1.65" x 6" x 8.5" (42 x 152 x 216 mm)	Adapter: 9VADAP available Batteries: 2 AA included	1 ea
Prod No	Capacity	Increments	H x W x D	Adapter/Batteries	Pack	
Large Square Kitchen Scale						
SCD613 Δ	13 lb (6 kg)	0.1 oz (1 g)	3.75" x 7.25" x 9.75" (95 x 184 x 284 mm)	Adapter: 9VADAP available Batteries: 9V included	1 ea	

NSF Listed products are designated with a Δ

*Specify desired color after item number. Example: SCDGP11BK



Low Profile Digital Scale

- Simple 2 button operation
- Sealed display
- Tare feature and automatic shut off
- Batteries included



SCDG13LP

M-Series Scale

- Display hold
- Sealed dual display
- Tare feature and automatic shut off
- Additional rear display
- Stainless steel removable weighing surface



SCDGM33

Mechanical Dial Scale

- Removable access panel
- Tare Feature
- Water resistant
- Analog – no batteries required



SCMDL5

Prod No	Capacity	Increments	H x W x D	Adapter/Batteries	Pack
Low Profile Digital Scale					
SCDG13LP Δ	13 lb (6 kg)	0.05 oz (0.5 g)	1.5" x 5.75" x 8.25" (38 x 146 x 210 mm)	Adapter: 9VADAP available Batteries: 2 AA included	1 ea
M-Series Scale					
SCDGM33 Δ	33 lb (15 kg)	0.1 oz (2 g)	4.15" x 10.25" x 12" (105 x 260 x 305 mm)	Adapter: 9VADAP available Batteries: 4 C included	1 ea
SCDGM66 Δ	66 lb (30 kg)	0.1 oz (2 g)	4.15" x 10.25" x 12" (105 x 260 x 305 mm)	Adapter: 9VADAP available Batteries: 4 C included	1 ea
Mechanical Dial Scale					
SCMDL2 Δ	2 lb (32 oz)	0.13 oz	8.5" x 6.75" x 6.5" (216 x 171 x 165 mm)	Analog - no batteries required	1 ea
SCMDL5 Δ	5 lb (80 oz)	0.5 oz	8.5" x 6.75" x 6.5" (216 x 171 x 165 mm)	Analog - no batteries required	1 ea
SCMDL25 Δ	25 lb	2 oz	8.5" x 6.75" x 6.5" (216 x 171 x 165 mm)	Analog - no batteries required	1 ea
SCMDL50 Δ	50 lb	4 oz	8.5" x 6.75" x 6.5" (216 x 171 x 165 mm)	Analog - no batteries required	1 ea

NSF Listed products are designated with a Δ



THERMOMETERS

Regulate temperature with **ease and accuracy** with **San Jamar's Pro MZR** line of thermometers. Whether monitoring cold storage temperatures, or ensuring food quality and consistency, our thermometers provide **unsurpassed value** and will be a chef-favored tool in any kitchen, for every application.



Gourmet Digital Thermometer

- Smooth comfort grip handle
- Stainless steel probe
- Sheath and pocket clip

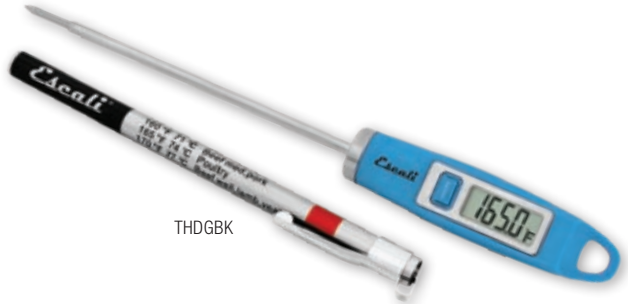

THDGBK

Digital Pen Thermometer

- Stainless steel probe
- Sheath doubles as extended handle
- Display hold



THDGPN

Oven Thermometer

- Oven safe
- HACCP hot food handling temp reminders
- Easy-read dial



THDLOV

Black(BK)	Blue(BL)					
Prod No	Color	Temp Rating	Length	Units	Digital/Analog	Pack
Gourmet Digital Thermometer						
THDG* Δ	BK, BL	-49°F to 392°F (-45°C to 200°C)	Probe: 4.75" (121 mm)	Celsius, Fahrenheit	Digital	1 ea
Prod No	Temp Rating	Length	Units	Digital/Analog	Pack	
Digital Pen Thermometer						
THDGPN Δ		32°F to 392°F (0°C to 200°C)	Probe: 3" (76 mm)	Celsius, Fahrenheit	Digital	1 ea
Prod No	Temp Rating	Dimensions	Units	Digital/Analog	Pack	
Oven Thermometer						
THDLOV Δ		40°F to 500°F (10°C to 260°C)	2.4" (61 mm)	Celsius, Fahrenheit	Analog	1 ea

NSF Listed products are designated with a Δ
 *Specify desired color after item number. Example: THDGBK



Digital Refrigerator/ Freezer Thermometer

- Large, easy to read display
- Magnetic back
- Kickstand or hanging display



THDGRF

TIMERS

The Extra Large Display Digital Timer is **easy to read** at greater distances and features a **clock mode** when not in use. Count up or down, recall last timer settings and mount it to a nearby refrigerator or set it on a countertop for **optimal visibility**.

Extra Large Display Digital Timer

- Counts up and down
- Flashing LED and loud alarm
- Magnetic stand
- Batteries included



TMDGXL

Prod No	Maximum Time	H x W x D	Batteries	Pack	
Extra Large Display Digital Timer					
TMDGXL	99 minutes, 59 seconds	3.5" x 3.25" x 0.75" (89 x 83 x 19 mm)	Batteries included	1 ea	
Prod No	Temp Rating	H x W x D	Units	Digital/Analog	Pack
Digital Refrigerator/Freezer Thermometer					
THDGRF	-4°F to 122°F (-20°C to 50°C)	2.75" x 1.75" x 0.5" (70 x 44 x 13 mm)	Celsius, Fahrenheit	Digital	1 ea



CUT PROTECTION

The Mani-Kare Bandage Dispenser provides **sanitary and secure** dispensing of bandages. Bandages dispense **ready-to-use** for easy application.

Mani-Kare® Bandage Dispenser & Bandages

- Pilferage-resistant with locked upper compartment
- Simple one-handed operation for ease of use
- One-at-a-time dispensing to reduce waste
- Wall-mounted to save space
- Blue colored bandages to avoid serving contaminated food
- Blue colored bandages are easily identifiable and metal detectable to ensure food product remains uncontaminated
- Beige colored bandages available

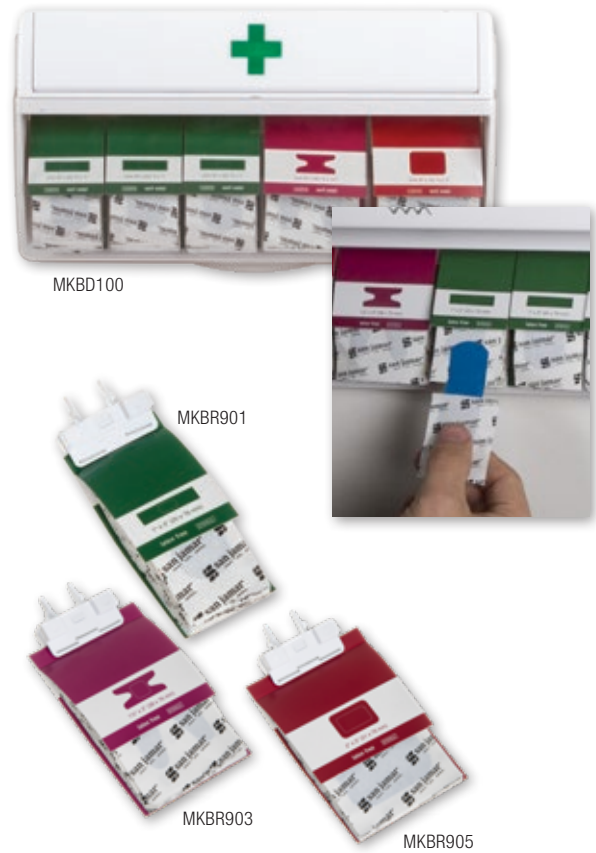

Prod No	Description	Color	H x W x D	Pack
Mani-Kare Bandage Dispenser				
MKBD100 Δ	Dispenser with blue bandage cartridges Includes: (1) large patch, (1) knuckle, (3) strip bandage cartridges, (1) quick user guide, (1) screw pack	Blue	6.38" x 12" x 2" (162 x 305 x 51 mm)	1 ea
MKBD100BE Δ	Dispenser with beige bandage cartridges Includes: (1) large patch, (1) knuckle, (3) strip bandage cartridges, (1) quick user guide, (1) screw pack	Beige	6.38" x 12" x 2" (162 x 305 x 51 mm)	1 ea
MKBR901 Δ	Blue strip bandage (3) cartridges of 15	Blue	1" x 3" (25 x 76 mm)	1 pk
MKBR901BE Δ	Beige strip bandage (3) cartridges of 15	Beige	1" x 3" (25 x 76 mm)	1 pk
MKBR903 Δ	Blue knuckle bandage (3) cartridges of 10	Blue	1.5" x 3" (38 x 76 mm)	1 pk
MKBR903BE Δ	Beige knuckle bandage (3) cartridges of 10	Beige	1.5" x 3" (38 x 76 mm)	1 pk
MKBR905 Δ	Blue large patch bandage (3) cartridges of 10	Blue	2" x 3" (51 x 76 mm)	1 pk
MKBR905BE Δ	Beige large patch bandage (3) cartridges of 10	Beige	2" x 3" (51 x 76 mm)	1 pk
MKQUG	Mani-Kare quick user guide laminated wall chart	Blue	3" x 12" (76 x 305 mm)	1 ea
MKQUGBE	Mani-Kare quick user guide laminated wall chart	Beige	3" x 12" (76 x 305 mm)	1 ea

Prod No	Shape	Description	L x W	Quantity	Pack
Mani-Kare Bandages					
MK0901		Strip bandages	1" x 3" (25 x 76 mm)	300 bandages (6 boxes of 50)	1 ea
MK0902		Small fingertip bandages	1.75" x 2" (44 x 51 mm)	240 bandages (6 boxes of 40)	1 ea
MK0903		Knuckle bandages	1.5" x 3" (38 x 76 mm)	240 bandages (6 boxes of 40)	1 pk
MK0904		Large fingertip bandages	1.75" x 3" (44 x 76 mm)	150 bandages (6 boxes of 25)	1 pk
MK0905		Large Patch bandages	2" x 3" (51 x 76 mm)	150 bandages (6 boxes of 25)	1 pk
MK0906	Assorted	Value pack: 2 boxes of MK0901, 1 box of MK0902, 1 box of MK0903, 1 box of MK0904, 1 box of MK0905	Assorted	100 strips (2 boxes), 40 small fingertips (1 box), 40 knuckles (1 box), 25 large fingertips (1 box), & 25 large patches (1 box)	1 pk
MK0909	Assorted	1 storage box with 1 MK0906	Assorted	Storage box with 100 strips (2 boxes), 40 small fingertips (1 box), 40 knuckles (1 box), 25 large fingertips (1 box), & 25 large patches (1 box)	1 pk

NSF Listed products are designated with a Δ

Bag Boa features a unique safety blade design to **reduce** the risk of **hand injury** and a durable polypropylene construction to prevent breakage.



Bag Boa™ Bag Cutter & Squeegee

- Safely open food bags
- Integrated squeegee eliminates food waste
- High-density plastic with stainless steel safety-type blade



Made with **state-of-the-art Dyneema material**, this glove provides dependable **ANSI Level A7 cut protection**.

Cut-Resistant Glove with Dyneema®

- 10 gauge Dyneema fiber
- Ambidextrous, lightweight and machine washable
- Provides a secure fit with excellent dexterity
- Available in five colors for HACCP color-coding
- ANSI level A7 cut protection



Prod No	H x W x D					Pack
Bag Boa Bag Cutter & Squeegee						
BB100 Δ	13.5" x 1.75" x 0.25" (330 x 44.5 x 6 mm)					1 ea
Prod No	Color	Size	Length	Material	Cut Protection	Pack
Cut-Resistant Glove with Dyneema						
SG10-*	White	S, M, L, XL	11" (279 mm)	Dyneema† composite yarn	Meets OSHA standard (29 CFR) 1910.132 - tested in accordance with ASTM Spec 177.20	1 ea
SG10-**	BL, GN, RD, YL, PR	S, M, L	11" (279 mm)	Dyneema† composite yarn	Meets OSHA standard (29 CFR) 1910.132 - tested in accordance with ASTM Spec 177.20	1 ea

NSF Listed products are designated with a Δ

*Specify desired size after item number. Example: SG10-S

**Specify desired color and size after item number. Example: SG10-BL-S

†Dyneema is a registered trademark of Royal DSM N.V. under license of Double Knitting & Glove, Inc.



HEAT & CHEMICAL PROTECTION

Protect vulnerable arms from inadvertent heat contact with our **Sleeve with Kevlar**.

Sleeve with Kevlar®

- Protects forearm against inadvertent heat contact
- Machine washable

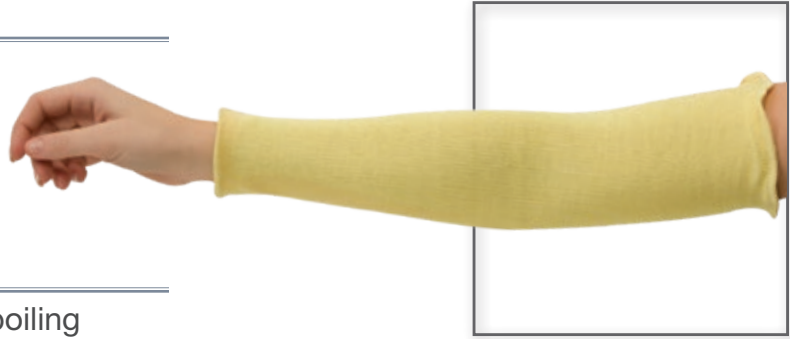

Protects against hot grease, boiling water, dangerous chemicals and vapors.

EZ-Kleen™ Full Body Protection Kit

- Oven mitt has a removable liner and protects up to 450°F for 15 seconds
- Face shield flips up as needed and features an adjustable headband
- Apron protects the torso and upper legs
- Shinguards and shoes have adjustable straps for a universal fit



Prod No	Length	Materials	Temperature Protection	Pack
Sleeve with Kevlar				
SLK16	18" (457 mm)	Kevlar	Up to 500°F (260°C) for 15 sec	1 ea

Prod No	Description	Pack
EZ-Kleen Full Body Protection Kit		
EZKKIT ♦	(2) 15" EZ-Kleen oven mitts, (1) EZ-Kleen face shield, (1) EZ-Kleen apron, (1 pair) EZ-Kleen shin guards	1 ea

Kevlar® is a registered trademark of DuPont

♦ California Residents: Bisphenol A **WARNING:** See appendix A on page 281



TEMPERATURE PROTECTION

Oven mitts with WebGuard which provide **extra heat protection** between thumb and forefinger.

UltiGrips® Oven Mitts & Hot Pads

- Non-slip, textured Neoprene material repels stains and provides superior grip ability in hot or cold applications
- Mitts provide WebGuard™ for extra protection and comfort
- Flexible and dishwasher safe



BestGuard® Oven Mitt with Kevlar® WebGuard™

- Exclusive technology provides superior heat protection while keeping hands cool
- Angled cuff for ease-of-movement and comfort
- Ambidextrous and fire retardant
- Kevlar® WebGuard™ for extra protection and comfort
- Wipes clean with damp cloth



Prod No	Size	Description	Temp Protection	Pack
UltiGrips Oven Mitts & Hot Pads				
UCMX*BK	13" (330 mm), 15" (381 mm), 17" (432 mm)	Conventional style mitt	-109°F (-78°C) up to 500°F (260°C) for 15 sec	1 ea
UPM*BK	15" (381 mm), 17" (432 mm)	Puppet style mitt	-109°F (-78°C) up to 500°F (260°C) for 15 sec	1 ea
UHP55BK	5.5" x 5.5" (140 x 140 mm)	Hot pad	-109°F (-78°C) up to 500°F (260°C) for 15 sec	1 ea
UHP77BK	7" x 7" (178 x 178 mm)	Hot pad	-109°F (-78°C) up to 500°F (260°C) for 15 sec	1 ea
UHP1010BK	10" x 10" (254 x 254 mm)	Hot pad	-109°F (-78°C) up to 500°F (260°C) for 15 sec	1 ea

Prod No	Length	Color	Description	Temp Protection	Pack
BestGuard Oven Mitt with Kevlar WebGuard					
800FG*	13" (330 mm), 15" (381 mm), 17" (432 mm), 24" (610 mm)	Tan	Conventional style	Up to 450°F (232°C) for 30 sec	1 pr
800FG*-BK	13" (330 mm), 15" (381 mm), 17" (432 mm), 24" (610 mm)	Black	Puppet style	Up to 450°F (232°C) for 30 sec	1 pr

*Specify desired length after item number. Example: 800FG13

Kevlar® is a registered trademark of DuPont



CHEMICAL PROTECTION

The ProGrip glove is the answer to wet and oily applications where safety is key.

ProGrip™ Chemical Gloves

- Cut and abrasion resistant
- Protection from a wide variety of chemicals
- Textured Nitrile coating gives it's user level 4 CE abrasion resistance
- FDA compliant (21CFR, 170-199)
- 45 milcuff/50 mil palm



Vinyl Dish Washing Apron

- Includes heavy-duty braided ties
- Institutional grade quality vinyl



614DVA-BL

Prod No	Size	Length	Material	Pack	
ProGrip Chemical Gloves					
CP14-*	S, M, L, XL	14" (356 mm)	Neoprene	1 ea	
Prod No	Color	Thickness	W x L	Material	Pack
Vinyl Dish Washing Apron					
614DVA-WH-**	White	6 mil, 8 mil	36" x 43" (91 x 109 cm)	Institutional grade quality vinyl	1 ea
614DVA-BL	Blue	8 mil	36" x 43" (91 x 109 cm)	Institutional grade quality vinyl	1 ea
614DVA	Clear	12 mil	36" x 43" (91 x 109 cm)	Institutional grade quality vinyl	1 ea

*Specify desired size after item number. Example: CP14-S

**Specify desired thickness after item number. Example: 614DVA-WH-6

● California Residents: Di(2-ethylhexylphthalate (DEHP) **WARNING:** See appendix B on page 281

■ California Residents: Styrene **WARNING:** See appendix C on page 281

SANITARY MAINTENANCE



The Smart System with IQ Sensor offers tremendous **versatility** and **reliability**. This dispenser has it all... **paper length** and **dispensing delay adjustments**, replaceable drive module, auto transfer combined with the **best sensor in the industry**.

Smart System Electronic Touchless Roll Towel Dispenser with I.Q. Sensor™

- Adjustable paper length (8", 12", 16") and delay (0, 1½, 3 seconds)
- Infinity System® automatic transfer system eliminates stub roll waste
- Replaceable drive module
- Touch-free operation provides a hygienic source of towels
- Quiet operation provides a pleasant atmosphere



T1470BKSS



T1400TBL



T1490TBK



T1470WHCL



Prod No	Color	Capacity	Core Diameter	H x W x D	Pack
Smart System Electronic Touchless Roll Towel Dispenser with I.Q. Sensor					
Classic Style					
T1400*	TBL, TBK, WH	8" (200 mm) wide roll dia. & 4" (100 mm) dia. stub roll	1.5" (38 mm)	16.5" x 11.75" x 9.25" (419 x 298 x 235 mm)	1 ea
T1400TBKHW**	TBK	8" (200 mm) wide roll dia. & 4" (100 mm) dia. stub roll	1.5" (38 mm)	16.5" x 11.75" x 9.25" (419 x 298 x 235 mm)	1 ea
Oceans® Style					
T1490*	TBL, TBK	8" (200 mm) wide roll dia. & 4" (100 mm) dia. stub roll	1.5" (38 mm)	16.5" x 11.75" x 9.25" (419 x 298 x 235 mm)	1 ea
Summit™ Style					
T1470*	BKSS, SS, WHCL, CUSTOM	8" (200 mm) wide roll dia. & 4" (100 mm) dia. stub roll	1.5" (38 mm)	16.06" x 12.69" x 9.75" (410 x 311 x 248 mm)	1 ea

*Specify desired color after item number. Example: T1400TBK

**Includes hand washing sticker



SANITARY MAINTENANCE

Rely[®] Electronic Hybrid Soap & Sanitizer Dispenser

- Touchless electronic soap and sanitizer dispensing
- Manual “push-the-cover” operation when batteries are low
- Accepts bulk hand sanitizers, lotion and foam soap
- Control dosage settings: full dose (1 ml) or half dose (0.5 ml)



SHF900TBK

SH970BKSS

The Arriba Twist Passive Air Care dispenser uses the **greenest air care technology** in the industry, including **100% recyclable refills**.

Arriba[™] Twist Passive

- QuickLoad[™] design reduces service time – no step stools or ladders needed
- Provides 60 days of air freshening
- No aerosols, sprays or batteries needed with the passive wick dispersion system



WP9070SS

WP9070WHCL

WP9070BKSS



Prod No	Color	Capacity	H x W x D	Pack
Rely Hybrid Soap & Sanitizer Dispensers				
Liquid & Lotion – Classic Style				
SH900*	TBL, TBK	875 ml (1 ml or 0.5 ml portion dispensed)	12" x 5.5" x 4" (305 x 140 x 102 mm)	1 ea
Liquid & Lotion - Summit Style				
SH970*	BKSS, SS, WHCL, CUSTOM	875 ml (1 ml or 0.5 ml portion dispensed)	12" x 5.5" x 4" (305 x 140 x 102 mm)	1 ea
Foam – Classic Style				
SHF900*	TBL, TBK	825 ml (1 ml or 0.5 ml portion dispensed)	12" x 5.5" x 4" (305 x 140 x 102 mm)	1 ea
Foam – Summit Style				
SHF970*	BKSS, SS, WHCL, CUSTOM	825 ml (1 ml or 0.5 ml portion dispensed)	12" x 5.5" x 4" (305 x 140 x 102 mm)	1 ea
Arriba Twist Passive				
WP 107 80 1202	Gray		2.88" x 4.63" x 2.88" (73 x 117 x 73 mm)	1 ea
WP 107 80 1203	White		2.88" x 4.63" x 2.88" (73 x 117 x 73 mm)	1 ea
Summit Style				
WP9070*	BKSS, SS, WHCL, CUSTOM		2.88" x 4.63" x 2.88" (73 x 117 x 73 mm)	1 ea

*Specify desired color after item number. Example: SH900TBK

Disposable Glove Dispensers prevent boxes from becoming damaged or contaminated and keep gloves sanitary and handy for use; essential at hand washing stations or food preparation areas.

Glove Dispensers

- Prevent boxes from becoming damaged or contaminated
- Available in single box and 3-box configurations to dispense multiple glove sizes



San Jamar's Venue line of napkin dispensers offer optimal, one-at-a-time dispensing of a variety of napkin types.

Venue® Countertop Napkin Dispenser with Stand

- Stand model enhances image and saves counter space
- One-at-a-time dispensing to save napkin waste
- Smooth dispensing down to the last napkin



Prod No	Color	Type	Capacity	H x W x D	Pack
Venue Countertop Napkin Dispenser with Stand					
H5000S*	CL, TBK	Minifold/Control Face	450+	17.25" x 8" x 13" (440 x 203 x 330 mm)	1 ea
H5005S*	CL, TBK	Fullfold/Control Face	450+	17.38" x 8" x 13" (441 x 203 x 330 mm)	1 ea
Prod No	Color	Capacity	Construction	Pack	
Glove Dispensers					
G0801	Stainless Steel	1 Box	22-gauge stainless steel	1 ea	
G0802	White	1 Box	22-gauge stainless steel with white baked enamel	1 ea	
G0804	White	3 Boxes	22-gauge stainless steel with white baked enamel	1 ea	
G0803	Clear	1 Box	High-grade flexible Plexiglas®	1 ea	
G0805	Clear	3 Boxes	High-grade flexible Plexiglas®	1 ea	

*Specify desired color after item number. Example: H5000SCL

PRODUCT INDEX

Prod No	Page No	Prod No	Page No	Prod No	Page No	Prod No	Page No
DINEX		DX24019000	52	DX5806	39	DX91-93	53
DX10053	136	DX2502POPO	55	DX5808	39	DX9200B	35
DX101-103	53	DX3000	30	DX5810	39	DX93-95	53
DX101-103DM	53	DX30008714	30	DX5810ST8714	39	DX9300B	35
DX1011120RS	76	DX30008775	30	DX5812	39	DX9300B7000	35
DX10251DT	136	DX3000RL	31	DX5812ST8714	39	DX9400B	35
DX103-105	53	DX3200	30	DX59-61	53	DX9407B	35
DX10454	95	DX3300	30	DX5900ST8714	38	DX95-97	53
DX10455	95	DX33008714	30	DX5999I00102	62	DX97-99	53
DX105-107	53	DX3300RL	31	DX5999M00102	63	DX99-101	53
DX107-109	53	DX3353	30	DX5999MEW02	63	DX9ACP	50
DX1077	37	DX3353IL	28	DX5999MEW50	63	DX9CP	50
DX1087	37	DX3400	30	DX5999MEW61	63	DXAC54	111
DX1089I	45	DX45-47	53	DX5999MEW84	63	DXAC56	111
DX1089M	45	DX47-49	53	DX5ACBP	50	DXCBE	36
DX1089MOC23	46	DX49-51	53	DX5CBPB	50	DXCIB	111
DX109-111	53	DX4GC12	39	DX5CFNB	50	DXCM1100C14	143
DX10CASS	50	DX4GC6	39	DX61-63	53	DXCM1101C14	143
DX111-113	53	DX4GC8	39	DX6243202836	69	DXCM1125	143
DX113-115	53	DX4GC9	39	DX63-65	53	DXCM1126	143
DX115-117	53	DX4T9	51	DX63501113	69	DXCTCAD1003	69
DX117-119	53	DX5000	27-28	DX65-67	53	DXCTCAD1041	69
DX1173X100	136	DX50008700	28	DX67-69	53	DXCTCAD35000	69
DX1173X50	136	DX50008714	28	DX69-71	53	DXCTCAD80003	69
DX1173X80	136	DX50008775	28	DX6999PF0184	69	DXCTCAD80061	69
DX1173XC10	136	DX5055I202833	62	DX6999PF0202	69	DXCTCADL1003	69
DX11810174	40	DX5055M202833	63	DX6CASS	50	DXCTCADL1041	69
DX11820174	41	DX5081A5	62	DX6SM0010000	70	DXCTCADNS1003	69
DX11830174	30	DX5081I202733	62	DX6SM016000	70	DXCTCADNS1041	69
DX11838714	52	DX5081M202733	63	DX6SM055000	70	DXCTCADS1003	69
DX11840174	42	DX5081M202733NS	63	DX6SM055109	70	DXCTCADS1041	69
DX11858700	52	DX5091M0000	63	DX6SM055190	70	DXCUT	111
DX11858714	52	DX51-53	53	DX6SM055300	70	DXD2180P	115
DX11868714	52	DX5200	27-28	DX6SM055354	70	DXD2180PL	115
DX11870174	41	DX5242I	62	DX6SM081000	70	DXD2180PW	116
DX11880174	50	DX5243I	62	DX6SM081109	70	DXD2180PWL	116
DX11890174	41	DX5243M	63	DX6SM0811585	70	DXD245P	114
DX119-121	53	DX53-55	53	DX6SM081190	70	DXD290P	115
DX1191ST8714	39	DX5300	27-28	DX6SM081222	70	DXD290PL	115
DX11928714	52	DX53008700	28	DX6SM081300	70	DXD290PW	116
DX1193ST8714	40, 52	DX53008714	28	DX6SM081354	70	DXD290PWL	116
DX11948700	52	DX5320I	62	DX6SM351109	70	DXD2VP	114
DX11948714	52	DX5320M	63	DX6SM351190	70	DXD3180P	115
DX11968714	52	DX5320MNS	63	DX6SM351300	70	DXD3180PL	115
DX1196ST8714	52	DX5322VHW	63	DX6SM351354	70	DXD3180PW	116
DX11988714	52	DX5323I	62	DX6SM351427	70	DXD3180PWL	116
DX11988714	40	DX5323J	63	DX6ST0010000	70	DXD345P	114
DX1198ST8714	40, 52	DX5331I	62	DX6ST0040000	70	DXD390P	115
DX11998714	52	DX5331M	63	DX71-73	53	DXD390PL	115
DX121-123	53	DX5333I	62	DX73-75	53	DXD390PW	116
DX121-123DM	53	DX5333M	63	DX75-77	53	DXD390PWL	116
DX1411	75	DX5350B	62	DX77-79	53	DXD3VP	114
DX14110	36	DX5350M	63	DX79-81	53	DXD4180P	115
DX20019000	52	DX5350RR	63	DX81-83	53	DXD4180PDT	115
DX20029000	52	DX5360M	63	DX811220	76	DXD4180PDTL	115
DX2002ST9000	52	DX5365M	63	DX8210	36, 76	DXD4180PDTW	116
DX2011208	75	DX5400	27	DX83-85	53	DXD4180PDTWL	116
DX21259000	40, 52	DX5402PCLR	55	DX85-87	53	DXD4180PL	115
DX2125ST9000	40, 52	DX55-57	53	DX87-89	53	DXD4180PW	116
DX21359000	52	DX55000174	41	DX89-91	53	DXD4180PWL	116
DX22259000	39, 52	DX5600ST8714	38	DX9000B	35	DXD445P	114
DX2225ST9000	39, 52	DX57-59	53	DX9000B7000	35	DXD445PDT	114

Prod No	Page No	Prod No	Page No	Prod No	Page No	Prod No	Page No
DXD490P	115	DXDCF47	106	DXDMC	109, 125	DXFSGH4	113
DXD490PDT	115	DXDCF4NR	106	DXDMC2	106	DXFSGH5	113
DXD490PDTL	115	DXDCF5	106	DXDOUT	85-86, 112	DXFSGH6	113
DXD490PDTW	116	DXDCF57	106	DXDST2	107	DXFSGHL2	113
DXD490PDTWL	116	DXDCF5NR	106	DXDST3	107	DXFSGHL3	113
DXD490PL	115	DXDCF6	106	DXDST4	107	DXFSGHL4	113
DXD490PW	116	DXDCF67	106	DXDST5	107	DXFSGHL5	113
DXD490PWL	116	DXDCF6NR	106	DXDST6	107	DXFSGHL6	113
DXD4VP	114	DXDCR45	107	DXDSW11	112	DXFSSL2	113
DXD4VPDT	114	DXDCR90	107	DXDSW11D	112	DXFSSL3	113
DXD5180P	115	DXDCS	107	DXDSW11T	112	DXFSSL4	113
DXD5180PDT	115	DXDCSD	107	DXDSW11TD	112	DXFSSL5	113
DXD5180PDTL	115	DXDDWS2	110, 119	DXDSW7	112	DXFSSL6	113
DXD5180PDTW	116	DXDDWS3	110, 119	DXDSW7D	112	DXFT12	38
DXD5180PDTWL	116	DXDDWS4	110	DXDSW7T	112	DXFT6	38
DXD5180PL	115	DXDDWS5	110	DXDSW7TD	112	DXFT9	38
DXD5180PW	116	DXDDWS6	110	DXDUS2	107	DXGB2	112
DXD5180PWL	116	DXDFT2	105	DXDUS3	107	DXGB3	112
DXD545P	114	DXDFT3	105	DXDUS4	107	DXGB4	112
DXD545PDT	114	DXDFT4	105	DXDUS5	107	DXGB5	112
DXD590P	115	DXDFT5	105	DXDUS6	107	DXGB6	112
DXD590PDT	115	DXDFT6	105	DXDVLCAST	119	DXH5455DN01	67
DXD590PDTL	115	DXDHAF	110	DXDVLCF2	118	DXH5455I003	66
DXD590PDTW	116	DXDHC2	104	DXDVLCF3	118	DXH5455M003	66
DXD590PDTWL	116	DXDHC3	104	DXDVLHF2	117	DXHC20	86
DXD590PL	115	DXDHC4	104	DXDVLHF2SL	118	DXHC24	86
DXD590PW	116	DXDHC5	104	DXDVLHF3	117	DXHCHANDLES	86
DXD590PWL	116	DXDHC6	104	DXDVLHF3SL	118	DXHCLATCH	86
DXD5VP	114	DXDHF2	102	DXDVLST2	119	DXHCMENU	86
DXD5VPDT	114	DXDHF2HIB	102	DXDVLST3	119	DXHCSLIDES	86
DXD6180P	115	DXDHF2SL	104	DXDVLUS2	119	DXHD2	111
DXD6180PDT	115	DXDHF3	102	DXDVLUS3	119	DXHD3	111
DXD6180PDTL	115	DXDHF3HIB	102	DVEC09	36	DXHD4	111
DXD6180PDTW	116	DXDHF3LL	104	DXFC5	41	DXHD5	111
DXD6180PDTWL	116	DXDHF3LR	104	DXFLP2	108	DXHD6	111
DXD6180PL	115	DXDHF3SL	104	DXFLP3	108	DXHH1	51
DXD6180PW	116	DXDHF4	102	DXFLP4	108	DXHH10	51
DXD6180PWL	116	DXDHF4HIB	102	DXFLP42	108	DXHH10A	51
DXD645P	114	DXDHF4LL	104	DXFLP43	108	DXHH20	51
DXD645PDT	114	DXDHF4LR	104	DXFLP44	108	DXHH20A	51
DXD690P	115	DXDHF5	102	DXFLP45	108	DXHH27B	51
DXD690PDT	115	DXDHF5HIB	102	DXFLP46	108	DXHH30	51
DXD690PDTL	115	DXDHF5LL	104	DXFLP5	108	DXHH8	51
DXD690PDTW	116	DXDHF5LR	104	DXFLP6	108	DXHH87	51
DXD690PDTWL	116	DXDHF6	102	DXFLPD2	108	DXHHC10	50
DXD690PL	115	DXDHF6HIB	102	DXFLPD3	108	DXHDM7	51
DXD690PW	116	DXDHOR12UCOVR	153	DXFLPD4	108	DXHPL7	51
DXD690PWL	116	DXDHOR12UCOVR2	153	DXFLPD5	108	DXHHSCM	52
DXD6VP	114	DXDHOR12UP	153	DXFLPD6	108	DXHHSCS	52
DXD6VPDT	114	DXDHOR20UP	153	DXFSEG	113	DXHR601DN01	67
DXDBC110	124	DXDHOR24UP	153	DXFSG2	113	DXHR601I001	66
DXDBC200	124	DXDHT2	103	DXFSG3	113	DXHR601M001	66
DXDBC30	124	DXDHT2HIB	103	DXFSG4	113	DXHS002DN01	67
DXDBC45	124	DXDHT3	103	DXFSG5	113	DXHS002I001	66
DXDBC70	124	DXDHT3HIB	103	DXFSG6	113	DXHS002M001	66
DXDCF2	106	DXDHT4	103	DXFSGFL2	113	DXHS052DN01	67
DXDCF27	106	DXDHT4HIB	103	DXFSGFL3	113	DXHS052I001	66
DXDCF2NR	106	DXDHT5	103	DXFSGFL4	113	DXHS052M001	66
DXDCF3	106	DXDHT5HIB	103	DXFSGFL5	113	DXHS104DN01	67
DXDCF37	106	DXDHT6	103	DXFSGFL6	113	DXHS105I001	66
DXDCF3NR	106	DXDHT6HIB	103	DXFSGH2	113	DXHS105M001	66
DXDCF4	106	DXDICF	109, 125	DXFSGH3	113	DXHS182DN01	67

PRODUCT INDEX

Prod No	Page No	Prod No	Page No	Prod No	Page No	Prod No	Page No
DXHS1821001	66	DXICTCAST8	149	DXIDT1C1222	133	DXIESORS5	161
DXHS182M001	66	DXICTCAST84P	149, 151	DXIDT1C1321	133	DXIESORS6	161
DXHS201DN01	67	DXICTCB	149	DXIDT1C1418	133	DXIESORS7	161
DXHS2011001	66	DXICTCC	149	DXIDT1C1520	133	DXIESORS8	161
DXHS201M001	66	DXICTDRAIN	149	DXIDT1C1622	134	DXIESORS9	161
DXHS325DN01	67	DXICTPH	149	DXIDT1E1418	134	DXIESORU	161
DXHS3251001	66	DXICTPT10	149	DXIDT1E1520	134	DXIESORW10	161
DXHS325M001	66	DXICTPT12	149	DXIDT1E1622	134	DXIESORW12	161
DXHS341DN01	67	DXICTPT16	149	DXIDT1S1418	134	DXIESORW14	161
DXHS3441001	66	DXICTPT20	149	DXIDT1S1520	134	DXIESORW16	161
DXHS344M001	66	DXICTPT202D	149	DXIDT1S1622	134	DXIESORW18	161
DXHS3451001	66	DXICTPT24	149	DXIDT2E1418	134	DXIESORW20	161
DXHS456DN01	67	DXICTPT242D	149	DXIDT2E1520	134	DXIESORW8	159
DXHS4561001	66	DXICTPT282D	149	DXIDT2E1622	134	DXIESR10	159
DXHS456M001	66	DXICTPT322D	149	DXIDT2S1418	134	DXIESR12	159
DXHS470DN01	67	DXICTTOW	149	DXIDT2S1520	134	DXIESR14	159
DXHS4701001	66	DXICTTR1	149	DXIDT2S1622	136	DXIESR16	159
DXHS470M001	66	DXICTTR2	149	DXIDTDR3	135	DXIESR18	159
DXHS6011001	66	DXICTTR3	149	DXIDTS1C1321	135	DXIESR20	159
DXHS601M001	66	DXICTTR4	149	DXIDTS1C1418	135	DXIESRC4	159
DXHS701DN01	67	DXICTWB	130	DXIDTS1C1520	135	DXIESRC5	159
DXHS7011001	66	DXIDP2E0912	130	DXIDTS1C1622	135	DXIESRC6	159
DXHS701M001	66	DXIDP2E1012	130	DXIDTS1S1418	135	DXIESRC7	159
DXHYDCP	87	DXIDP2E1200	131	DXIDTS1S1520	135	DXIESRC8	160
DXHYDCT	87	DXIDP200912	131	DXIDTS1S1622	135	DXIESSB10	160
DXHYDES	87	DXIDP201012	131	DXIDTS2S1418	135	DXIESSB12	160
DXHYDFLP	87	DXIDP201200	130	DXIDTS2S1520	135	DXIESSB14	160
DXHYDFLPD	87	DXIDP3E0912	130	DXIDTS2S1622	129	DXIESSB16	160
DXHYDL	87	DXIDP3E1012	130	DXIDWB20900	129	DXIESSB18	160
DXHYDLSD	87	DXIDP3E1200	131	DXIDWB30900	160	DXIESSB20	160
DXHYDRSD	87	DXIDP300912	131	DXIESB10	160	DXIESSB8	159
DXHYDSGR	87	DXIDP301012	131	DXIESB12	160	DXIESSW10	159
DXIACPHC0912	132	DXIDP301200	128	DXIESB14	160	DXIESSW12	159
DXIACPHC1012	132	DXIDPC20120	128	DXIESB16	160	DXIESSW14	159
DXIACPHC1200	132	DXIDPC30180	132	DXIESB18	160	DXIESSW16	159
DXIADWB	132	DXIDPDS0912	132	DXIESB20	160	DXIESSW18	159
DXIBDRS180	136	DXIDPDS1012	132	DXIESB8	159	DXIESSW20	111
DXIBDRS270	136	DXIDPDS1200	130	DXIESFB10	159	DXINTS2	111
DXIBDRS90	136	DXIDPH2E0912	130	DXIESFB12	159	DXINTS3	111
DXICATABLEMSS	79, 156	DXIDPH2E1012	130	DXIESFB14	159	DXINTS4	111
DXICATABLESS	79, 156	DXIDPH2E1200	131	DXIESFB16	159	DXINTS5	111
DXICT10	149	DXIDPH200912	131	DXIESFB18	159	DXINTS6	78
DXICT10S	149	DXIDPH201012	131	DXIESFB20	159	DXIQTEC	123
DXICT12	149	DXIDPH201200	130	DXIESFB8	161	DXIRAC15DOELS	123
DXICT16	149	DXIDPH3E0912	130	DXIESO1PH	161	DXIRAC15DOERS	136
DXICT1T1DS9CC	149	DXIDPH3E1012	130	DXIESO1PHT	161	DXIRDS9100	136
DXICT20	149	DXIDPH3E1200	130	DXIESO3PH	161	DXIRDS9150	136
DXICT202D	149	DXIDPH4E0912	130	DXIESO3PHT	161	DXIRDS950	92
DXICT24	149	DXIDPH4E1012	130	DXIESOAMP	161	DXISERVVISION	157
DXICT242D	149	DXIDPH4E1200	132	DXIESOBW	161	DXISS60	157
DXICT282D	149	DXIDPHD0912	132	DXIESOCP	161	DXISS72	37
DXICT2DTR3	149	DXIDPHD1012	132	DXIESOCS1	161	DXK335C9	55
DXICT322D	149	DXIDPHD1200	129	DXIESOCS2	161	DXL200PCLR	54
DXICT3DTR4	149	DXIDPWB20900	137	DXIESOFJ	161	DXL4000PCLR	54
DXICT6S	149	DXIDRC1020	137	DXIESOOS	161	DXL4000PDCLR	55
DXICT7S	149	DXIDRC2020	137	DXIESORS10	161	DXL500PCLR	55
DXICT8S	149	DXIDRD1020	137	DXIESORS12	161	DXL500PDCLR	55
DXICTABLE	78	DXIDRD2020	137	DXIESORS14	161	DXL5400PCLR	55
DXICTABLEM	78	DXIDRE1020	137	DXIESORS16	161	DXL5400PDCLR	54
DXICTCAST54S	149, 151	DXIDRE2020	137	DXIESORS18	161	DXL800PCLR	54
DXICTCAST6	149	DXIDRS1020	137	DXIESORS20	161	DXL800PDCLR	54
DXICTCAST64S	149, 151	DXIDRS2020	133	DXIESORS4	161	DXL900PDCLR	112

Prod No	Page No	Prod No	Page No	Prod No	Page No	Prod No	Page No
DXLCFC	111	DXPSCPT14	151	DXSUSIGNCUSTOM	143	DXTQ1T2D3C30	146
DXLEGS2-4	111	DXPSCPT16	151	DXSUSIGNLOGO	143	DXTQ2T1D10	145
DXLEGS2-6	110	DXPSCPT20	151	DXSUSIGNPEDIAT	143	DXTQ2T1D10CC	147
DXMD2	110	DXPSCPT202D	151	DXSUSMA	143	DXTQ2T1D12	145
DXMD3	110	DXPSCPT24	151	DXSUSOA	143	DXTQ2T1D14	145
DXMD4	110	DXPSCPT242D	151	DXSWA7	112	DXTQ2T1D16	145
DXMD5	110	DXPSCPT282D	151	DXSWA711	112	DXTQ2T1D16CC	147
DXMD6	110	DXPSCPT322D	151	DXSWC12	41	DXTQ2T1D18	145
DXMEDERN	110	DXPSCTR1	151	DXSWC5	41	DXTQ2T1D20	145
DXMID	82	DXPSCTR2	151	DXSWC6	41	DXTQ2T1D20CC	147
DXMOC20RCDX1387	82	DXPSCTR3	151	DXSWC8	41	DXTQ2T1DPT10	145
DXMOCII20	133	DXPSCTR4	151	DXSWI11	112	DXTQ2T1DPT12	145
DXMOCTD	85	DXPSCWB	151	DXSWI7	112	DXTQ2T1DPT14	145
DXMTX7C	85-86, 95	DXPSUCC	95	DXT5400PCLR	55	DXTQ2T1DPT16	145
DXMTX8C	85-86, 95	DXPSUCR	95	DXT5400PDCCLR	55	DXTQ2T1DPT18	145
DXMTXDDES	85-86	DXPSUES	95	DXTAIII4782002	83, 92	DXTQ2T1DPT20	145
DXMTXFLP	85-86	DXPSUFLP	95	DXTAIII4782003	83, 92	DXTQ2T2D20	146
DXMTXHH	85	DXPSUFTS	95	DXTAIII4782102	92	DXTQ2T2D24	146
DXMTXHR	86	DXPSUTB	95	DXTAIII4782103	92	DXTQ2T2D24CC	147
DXMTXSCHN1	85, 95	DXPSUTP	95	DXTAIII4782202	92	DXTQ2T2D28	146
DXMTXTD	85, 95	DXRB1D	111	DXTAIII4782203	92	DXTQ2T2D28CC	147
DXMTXTDVC33U	85-86, 95	DXRB2D	111	DXTAIII4792020	83, 92	DXTQ2T2D32	146
DXMTXTS	85, 86	DXRLWR1	31	DXTAIII47920204	92	DXTQ2T2D32CC	147
DXMW201PBLK	55	DXRST1520	45	DXTAIII4792024	83, 92	DXTQ2T2D36	146
DXMW4016PBLK	54	DXRST1520NSQ	45	DXTAIII47920244	92	DXTQ2T2DPT20	146
DXMW4024PBLK	54	DXRUT3	112	DXTAIII4792026	83, 92	DXTQ2T2DPT24	146
DXMW4032PBLK	54	DXRUT4	112	DXTAIII47920264	92	DXTQ2T2DPT28	146
DXMW508PBLK	55	DXRUT5	112	DXTAIII4792030	83, 92	DXTQ2T2DPT32	146
DXMW512PBLK	55	DXRUT6	112	DXTAIII47920304	92	DXTQ2T2DPT36	146
DXMW516PBLK	55	DXSB12	42	DXTAIII4794004	92	DXTQCAST54S	152
DXMW5401PBLK	55	DXSB6	42	DXTAIII4794010	92	DXTQCAST64S	147
DXMW5501PBLK	55	DXSB9	42	DXTAIII4794012	92	DXTQCAST84P	147
DXMW5501PNAT	55	DXSC1321MB	46	DXTAIII4794013	92	DXTQCAST84S	147
DXMW810PBLK	54	DXSC1531002	46, 93	DXTAIII4794014	92	DXTQTOPR31T1D	147
DXMW812PBLK	54	DXSKR2	111	DXTAIII4794015	92	DXTQTOPR31T2D	147
DXMW813PBLK	54	DXSKR3	111	DXTAIII4794020	92	DXTQTOPR31T2D3C	147
DXMW912PBLK	54	DXSKR4	111	DXTAIII4794021	92	DXTQTOPR32T1D	147
DXMW916PBLK	54	DXSKR42	111	DXTAIII4794040	92	DXTQTOPR32T2D	147
DXOHS2	113, 119	DXSKR43	111	DXTAIII4935002	92	DXTQTOPR41T1D	147
DXOHS3	113, 119	DXSKR44	111	DXTAIII4940100	92	DXTQTOPR41T2D	147
DXOHS4	113	DXSKR45	111	DXTMP1097A	37	DXTQTOPR41T2D3C	147
DXOHS5	113	DXSKR46	111	DXTMP30-176	79, 157	DXTQTOPR42T1D	147
DXOHS6	113	DXSKR5	111	DXTMP30-240	79, 157	DXTQTOPR42T2D	147
DXPSC10	151	DXSKR6	111	DXTMPHNDLIFT	37	DXTQWB1T1D	147
DXPSC12	151	DXSMC1418NSM	44	DXTMPLIFTER	37	DXTQWB1T2D	147
DXPSC14	151	DXSMC1418NSQ	44	DXTMPSTARTER	157	DXTQWB1T2D3C	147
DXPSC16	151	DXSMC1520NSM	44	DXTMPVACCUP3	37	DXTQWB2T1D	147
DXPSC20	151	DXSMC1520NSQ	44	DXTMPVACCUP4	37	DXTQWB2T2D	147
DXPSC202D	151	DXSQD10	41	DXTOWHITCHNR-2	92	DXTS3B2	110
DXPSC24	151	DXSSPH	112	DXTPEFP	112	DXTS3B3	110
DXPSC242D	151	DXSU1T1D6	143	DXTQ1T1D6	145	DXTS3B4	110
DXPSC282D	151	DXSU1T1D8	143	DXTQ1T1D8	145	DXTS3B5	110
DXPSC2DTR3	151	DXSU2T1D10	143	DXTQ1T1DS9CC	145	DXTS3B6	110
DXPSC322D	151	DXSU2T1D12	143	DXTQ1T2D10	146	DXTSBP5CNT6	147
DXPSC3DTR4	151	DXSU2T1D16	143	DXTQ1T2D12	146	DXTSBP5CNT8	147
DXPSCCAST6	151	DXSU2T1D20	143	DXTQ1T2D14	146	DXTSBP5FRT6	147
DXPSCCAST8	151	DXSU2T1DPT10	143	DXTQ1T2D16	146	DXTSBP5FRT8	147
DXPSCCB	151	DXSU2T1DPT12	143	DXTQ1T2D18	146	DXTSBP66	147
DXPSCDRAIN	151	DXSU2T1DPT16	143	DXTQ1T2D20	146	DXTSBP68	147
DXPSCPH	151	DXSUPQC48	143	DXTQ1T2D3C21	146	DXTSDRAIN	147
DXPSCPT10	151	DXSUPSDL	143	DXTQ1T2D3C24	146	DXTSLATCH	147
DXPSCPT12	151	DXSUSCH	143	DXTQ1T2D3C27	146	DXTSMENU	147

PRODUCT INDEX

Prod No	Page No	Prod No	Page No	Prod No	Page No	Prod No	Page No
DXTSPFMA84	147	10236U	198	10496U	200	10763	206
DXTSPFMA86	147	10238Z	198	10510U	200	10764	206
DXTSSR2	110, 119	10239Z	198	10511U	200	10765	206
DXTSSR3	110, 119	10240B	198	10516U	200	10766	206
DXTSSR4	110	10240Z	198	10518Z	200	10767	206
DXTSSR5	110	10241B	198	10519Z	200	10768	206
DXTSSR6	110	10250U	198	10535	200	10769	206
DXTSTOW	147	10256U	198	10536U	200	10770	206
DXTSWALLSAVER	147	10270U	199	10537U	200	10771	206
DXTT1	51	10271U	199	10538Z	200	10772	206
DXTT20	51	10276U	199	10539Z	200	10773	206
DXTT30	51	10277U	199	10601	143, 171	1200	207
DXTT39	52	10278Z	199	10602	171	1202	207
DXTT58	52	10279Z	199	10610	204	1205	207
DXTT59	52	10280Z	199	10611	204	1252	207
DXTT6	51	10290U	199	10611C	204	1800	207
DXTT8	51	10291U	199	10612	204	1805	207
DXTVL2T1D10	152	10296U	199	10612C	204	2200	207
DXTVL2T1D12	152	10297U	199	10617	204	2205	207
DXTVL2T1D14	152	10310U	199	10617C	204	30580	199, 200
DXTVL2T1D16	152	10311U	199	10620	204	30581	199, 200
DXTVL2T1D18	152	10316U	199	10621	204	30582	199, 200
DXTVL2T1D20	152	10317U	199	10621C	204	30583	199, 200
DXTVLDOR10	152	10318Z	199	10622	204	30660	199
DXTVLDOR12	152	10319Z	199	10622C	204	30661	199
DXTVLDOR14	152	10335	199	10623	204	30662	199
DXTVLDOR16	152	10336U	199	10623C	204	30669	199
DXTVLDOR18	152	10337U	199	10624	204	30670	199
DXTVLDOR20	152	10338Z	199	10624C	204	30680	199
DXTVLTR3	152	10339Z	199	10627	204	30681	199
		10400B	200	10627C	204	30682	199
		10401B	200	10628	204	30683	199
		10402B	200	10629	204	30684	199
		10410U	200	10630	205	30685	199
		10411U	200	10631	205	30686	199
		10415	200	10632	205	30687	199
		10416U	200	10637	205	30688	199
		10417U	200	10640	205	30689	199
		10420B	200	10641	205	30695	199
		10421B	200	10642	205	30860	200
		10422B	200	10643	205	30861	200
		10423B	200	10644	205	30862	200
		10430U	200	10647	205	30869	200
		10431U	200	10648	205	30870	200
		10435	200	10720	203	30880	200
		10436U	200	10721	203	30881	200
		10437U	200	10722	203	30882	200
		10438Z	200	10723	203	30883	200
		10439Z	200	10724	203	30884	200
		10440B	200	10725	203	30885	200
		10440Z	200	10726	203	30886	200
		10441B	200	10730	203	30887	200
		10450U	200	10731	203	30888	200
		10470U	200	10732	203	30895	200
		10471U	200	10733	203	30896	200
		10476U	200	10734	203	33000	166
		10477U	200	10735	203	33002	166
		10478Z	200	10736	203	33004	166
		10479Z	200	10740	203	33006	166
		10480Z	200	10741	203	33008	166
		10490U	200	10742	203	33010	166
		10491U	200	10761	206	33012	166

FOODSERVICE

0200	207
0202	207
0203	207
0205	207
0350	207
0355	207
0600	207
0602	207
0603	207
0605	207
0800	207
0805	207
10200B	198
10201B	198
10202B	198
10203B	198
10210U	198
10211U	198
10212B	198, 200
10215	198
10216U	198
10217U	198
10220B	198
10221B	198
10222B	198
10223B	198
10230U	198
10231U	198
10232B	198, 200
10235	198

Prod No	Page No	Prod No	Page No	Prod No	Page No	Prod No	Page No
33016	166	36910	249	40002C	230	41083	233
33018	166	36911	249	40003	230	41093	236
33020	166	369210	249	40003C	230	41225	233
33024	166	369320	238	40004	230	41520	232
33030	167	369365	240	40004C	230	41664	240
33032	167	369375	240	40005	230	43141	193
33034	167	36941	241	40005C	230	43142	193
33036	167	369412B	237	40006	230	43143	193
33038	167	369413B	237	40006C	230	43144	193
33040	167	369418B	237	40007	230	43145	193
33042	167	369419B	237	40007C	230	45772	232
33080	167	36942	241	40008	230	4921	192
33082	167	369420	238	40008C	230	4922	192
33086	167	369424B	237	40010	230	4923	192
341010	248	369425B	237	40010C	230	4924	192
341011	248	369430	237	40026	232	4925	192
341020	248	369442B	237	40076	235	4926	192
341021	248	369448B	237	40081	235	4927	192
341032	248	369454B	237	40082	235	4928	192
341033	248	369460	237	40083	235	4929	192
341034	248	369472B	237	40110	232	4930	192
341035	248	369475	240	40111	232	4931	192
341044	248	369478B	237	40112	232	4932	192
341045	248	369484B	237	40113	232	4933	192
341055	248	369550B	237	40144	236	4961	192
341056	248	369551B	237	40146	236	4962	192
341057	248	369552B	237	40147	236	4963	192
341132	248	369595	240	40148	236	4964	192
341144	248	369670B	238	40225	236	4965	192
342015	249	369674B	238	40236	236	4966	192
342023	249	36968	240	40237	236	4967	192
342024	249	36970	240	40261	236	4968	192
342025	249	369724	239	40275	232	5024CE29AF	178
361410	234	369732	239	40290	232	5024EG29AF	178
361412	234	369811B	239	40291	232	5024FW29AF	178
361415	234	369814B	239	40293	232	51515252SM	180
361416	234	369816B	239	40294	232	53000	164
361420	234	369817B	239	40340	240	53001	164
3620194	233	369819B	239	40378	190	53002	164
3620294	233	369820B	239	40379	190	53003	164
363725	232	369824B	239	40395	190	53004	164
36567	235	369832	239	40396	190	53005	164
36568	235	38655	213	40397	190	53006	164
366918	235	3956	192	40398	190	53007	164
366922	235	3957	192	40399	190	53008	164
3672231	249	3958	192	40400	190	53009	164
36861	233	3959	192	40401	190	53010	164
36865	233	3960	192	40402	190	53011	164
36867	233	3961	192	40422	231	53135054L	180
36868	233	3970	192	40423	231	53182554L	180
36885	233	3971	192	40500	231	53201554L	180
36900	241	3980	192	40501	231	53771822NH	179
36904	241	3981	192	40501C	231	53781717NM	179
36905	241	3990	192	40521	230	53782020NM	179
369066B	240	3991	192	40541	231	53785252SM	177
369070B	240	3992	192	40542	231	537852AITM	177
369074B	240	3993	192	40545	231	53785454SM	177
36908	241	40000	230	40546	231	537854AUTM	177
36908C	241	40000C	230	40650	233	53785858SM	177
36908W	241	40001	230	40681	193	53787272SM	177
369082	240	40001C	230	40682	193	537876RM	177
36909	241	40002	230	41082	233	537890RM	177

PRODUCT INDEX

Prod No	Page No	Prod No	Page No	Prod No	Page No	Prod No	Page No
53931717NM	179	607136	202	C93	225	DXCM1126	209
53935252SM	177	607140C	202	CC11SH	245	EMB5026AC630	176
54001	165	607140CS	202	CC11TH	245	EMB5026AC830	176
54002	165	607142	202	CC2036	245	EMB5026BS10	176
54003	165	607144	202	CC2036DP	245	EMB5026BS25	176
54004	165	607146	202	CC2036P	245	EMB5026BS5	176
54005	165	607160C	202	CC2243	245	EMB5026HT30	176
54007	165	607160CS	202	CD2036	245	EMB5026LTRC	176
54018	165	607162	202	CH03	171	EMB5026R24	176
54019	165	607164	202	CH15	171	EMB5026R72	176
59035252SM	180	607166	202	CM1012	213	EMB5026RT630	176
59085252SM	180	607190C	202	CM1013	213	EMB5026RT830	176
5CC118MP-12	178	607190CS	202	CM10238Z	211	EMB5026TLC23	176
5CC120MP-12	178	607192	202	CM10239Z	211	EMB5026TRC	176
5CC200PC-12	178	607194	202	CM10240Z	211	EMB5026TT27014	176
5CC55PC-12	178	607230C	202	CM10278Z	211	EMB5026WC35	176
5CCCCLIP-12	178	607232	202	CM10279Z	211	EMB5026WC44	176
5CCLCLIP-12	178	607236	202	CM10280Z	211	EMB5026WC55	176
60300-10	191	607550	193	CM10318Z	211	IT1000	184
60300-12	191	607552	193	CM10319Z	211	IT140	185
60300-16	191	607556	193	CM1040	212	IT160	185
60300-20	191	607560	193	CM1042	212	IT180	185
60300-24	191	607562	193	CM1042LP	212	IT250	184
60300-30	191	607566	193	CM1043	212	IT400	185
60300-40	191	608002	202	CM1045	212	IT410	185
60300-6	191	608004	202	CM1046	212	IT500	184
60300-8	191	608006	202	CM1049	212	N44010	227
604360	191	608122	202	CM1100	210	N44011	227
604361	191	608124	202	CM1100C14	209	N44012	227
604370	191	608126	202	CM1101	210	PC140N	186
604371	191	608132	202	CM1101C14	209	PC160N	186
604380	191	608134	202	CM1102	210	PC180N	186
604381	191	608136	202	CM1102C14	209	PC300N	186
604390	191	608142	202	CM1103	210	PC600N	186
604392	191	608144	202	CM1103C14	209	PC660	187
6070A	201	608146	202	CM1104	210	RB	223
607000C	202	608162	202	CM1104C14	209	RC16	224
607000CS	202	608164	202	CM1105	210	RC16-1	224
607000H	202	608166	202	CM1105C14	209	RC20	224
60700HL2	202	608192	202	CM1107	209	RC20-1	224
60700HL4	202	608194	202	CM1108	209	RDC	226
60700HL6	202	608236	202	CM1125	209, 210	RDC1	226
60700HLC	202	70900	168	CM1126	209, 210	RE	220-223
607001	202	70901	168	CM1127	210	RE16	221
607002	202	70902	168	CM1128	210	RE16C	221
607002P	202	70903	168	CM1400	213	RE25	221
607004	202	70904	168	CM1401	213	RE25C	221
607004P	202	70905	168	CM1402	213	RE36	222
607006	202	7550	170	CM1403	213	RE36C	222
607006P	202	7555	170	CM1404	213	RE49	222
6071A	201	C111	225	CM1405	213	RE49C	222
607120C	202	C135	225	CM1406	213	RE9	220
607120CS	202	C2220A	226	CM1407	213	RE9C	220
607122	202	C2222A	226	CM1408	213	REW20S	219
607122P	202	C2222C	226	CP2036	245	REW20SC	219
607124P	202	C2222HD	226	CW6C	225	REW30S	219
607124	202	C2236	226	DL1826	187	REW30SC	219
607126	202	C2236H	226	DL300	187	RF	223
607130C	202	C2237	226	DL300R	187	RFP	224
607130CS	202	C32P1	225	DXCM1100C14	209	RG16	221
607132	202	C32P2	225	DXCM1101C14	209	RG16-1	221
607134	202	C35P	225	DXCM1125	209	RG16-1C	221

Prod No	Page No	Prod No	Page No	Prod No	Page No	Prod No	Page No
RG16-2	221	RW20-3	219	CB152012	252	SCMDL5	261
RG16-2C	221	RW20-3C	219	CB152012WH	252	SCMDL50	261
RG16-3	221	RW20-4C	219	CB182412	252	SFC1200CL	258
RG16-3C	221	RW20-C	219	CB182412WH	252	SFC1200QT	258
RG16-4	221	RW30	219	CB182434	252	SFC1250CL	258
RG16-4C	221	RW30-1	219	CBG121812	252	SFC1250QT	258
RG16-5	221	RW30-1C	219	CBG152012	252	SFCROLLCL	258
RG16-5C	221	RW30-2	219	CBG182412	252	SFCROLLQT	258
RG25	221	RW30-2C	219	CBG912	252	SG10	265
RG25-1	221	RW30-3	219	CBGW152012	252	SH900	270
RG25-1C	221	RW30-3C	219	CBGW912	252	SH970	270
RG25-2	221	RW30-4C	219	CBM1016	253	SHF900	270
RG25-2C	221	RW30-C	219	CBM1318	253	SHF970	270
RG25-3	221	SBC11SH	246	CBM1622	253	SI5000	257
RG25-3C	221	SBC11TC	246	CBMASZ1212	253	SI6000	256
RG25-4	221	SBC1521	245	CBMASZ2430	253	SI6100	256
RG25-4C	221	SBC2031	245	CP14	268	SI7000	257
RG25-5	221	SBC230	246	EZKIT	266	SI7700	257
RG25-5C	221	SBCA30000	245	FC1212-RD	259	SI9000	257
RG36	222	SBCC240	245	FC2212-RD	259	SICART60	256
RG36-1	222	SBCC245	245	G0801	271	SICART61	256
RG36-1C	222	SBCRKIT	245	G0802	271	SLK16	266
RG36-2	222	SS105	171	G0803	271	STK1006	254
RG36-2C	222	TC1826N	186	G0804	271	STK1006GRL	254
RG36-3	222	UC1940	247	G0805	271	STK1006PRL	254
RG36-3C	222	UC3031524	246	H5000S	271	STK1006RDL	254
RG36-4	222	UC3031827	246	H5005S	271	STK1006YLL	254
RG36-4C	222	UC4018	247	KP196	258	STK1008	254
RG36-5	222	UC4031529	246	KP256	258	SW12	255
RG36-5C	222	UC4031733	246	KP256WM	258	SW18	255
RG49	222	UC4525	247	KP320	258	SWX100	255
RG49-1	222	UC5031524	246	KP97	258	T1400	269
RG49-1C	222	UC5031827	246	KPS196	258	T1400TBKHW	269
RG49-2	222	UC5032135	246	KPS196WM	258	T1470	269
RG49-2C	222	UC7022133	246	KPS97	258	T1490	269
RG49-3	222	UC7032133	246	KPS97WM	258	THDG	262
RG49-3C	222	UCC4018	247	MK0901	264	THDGPN	262
RG49-4	222	UCC4525	247	MK0902	264	THDGRF	263
RG49-4C	222	XDL3000H	187	MK0903	264	THDLOV	262
RG49-5C	222			MK0904	264	TMDGXL	263
RG9	220			MK0905	264	UCMXBK	267
RG9-1	220	SAN JAMAR		MK0906	264	UHP1010BK	267
RG9-1C	220	614DVA	268	MK0909	264	UHP55BK	267
RG9-2	220	614DVA-BL	268	MKBD100	264	UHP77BK	267
RG9-2C	220	614DVA-WH	268	MKBD100BE	264	UPMBK	267
RG9-3	220	800FG	267	MKBR901	264	WP 107 80 1202	270
RG9-3C	220	800FG-BK	267	MKBR901BE	264	WP 107 80 1203	270
RG9-4	220	ASZ121812SYS	253	MKBR903	264	WP9070	270
RG9-4C	220	BB100	265	MKBR903BE	264		
RG9-5	220	BD100S	259	MKBR905	264		
RG9-5C	220	BD2001	259	MKBR905BE	264		
RHC	226	BD2002	259	MKQUG	264		
ROP	223	BD2002CAR	259	MKQUGBE	264		
RP	223	BD4003	259	RCU128V2	257		
RPC	224	BD4004	259	RCU64V2	257		
RSP	224	BD4014	259	SCDG13	260		
RTP	223	BDS2203	259	SCDG13LP	261		
RW20	219	BDS2483NL	259	SCDGM33	261		
RW20-1	219	BDS4266	259	SCDGM66	261		
RW20-1C	219	CB101212	252	SCDGP11	260		
RW20-2	219	CB121812	252	SCMDL2	261		
RW20-2C	219	CB121812WH	252	SCMDL25	261		
RW20-2C	219	CB121834	252				

TERMS & CONDITIONS — Dinex

1. Terms and Method of Payment

- a. All orders are subject to approval and acceptance by SELLER. No order accepted by SELLER shall be subject to cancellation, termination, suspension, change, reduction, cutback or other modification except with SELLER'S prior written consent.
- b. Our standard terms of payment are net 30 days from invoice date. The amount of terms of credit, if extended, may be changed or credit withdrawn by SELLER at any time. No orders will be shipped on a COD basis.
- c. Prices do not include federal, state or local taxes, duties or other levies, now or hereafter enacted, applicable to the items deliverable under the sales order or invoice (hereinafter called ITEMS), which taxes, duties, or other levies will be added by SELLER to the sales price and will be paid by BUYER unless BUYER provides SELLER with a proper exemption certificate.
- d. Packaging for commercial shipment is included in the contract price. Any special packaging, crating or shipping instructions must be noted on BUYER'S original order and acknowledged by SELLER.

2. Title and Delivery

The ITEMS shall be delivered F.O.B. SELLER'S plant, and title thereto shall pass to BUYER, upon SELLER'S delivery of the ITEMS to a common carrier for shipment to BUYER. Freight is prepaid on all orders (except for equipment products and customer products) of 150 cases and over to one destination within the contiguous 48 United States. Transportation charges for all capital equipment (includes drying & storage carts, delivery carts, base heaters, etc.) are prepaid and added to invoice. Freight on prepaid International Shipments will be paid on normal ground transportation from shipping point to the consignee. When the order qualifies for prepaid freight, Seller shall have the right to select the means of transportation. If Buyer requires a means of transportation other than the one normally selected by Seller, any extra cost incurred by reason of using such other means shall be paid by Buyer. Palletized international orders requiring heat treated pallets will be charged \$4.25 net per pallet. International orders requiring heat treated certified bark-free pallets will be charged \$18.50 net per pallet. Any accessorial charges incurred because of a customer request will be the responsibility of the requester. Any items backordered from a prepaid shipment will be forwarded prepaid. Items backordered from ex works shipments will be forwarded ex works.

3. Inspection and Acceptance

Thoroughly inspect all shipments. Do not accept a damaged or short shipment until exception is noted on the freight bill. BUYER will be held responsible for all shipments with freight bills signed free and clear. If concealed damage is discovered, contact the freight company immediately for inspection. Concealed damage must be reported to the carrier within 7 days of receipt. All damaged goods and shortages that are not properly documented and reported upon receipt become the sole responsibility of the BUYER.

4. Patent Indemnification

SELLER shall protect and indemnify BUYER and its directors, officers, agents and employees against all claims for damages or profits, including all reasonable costs incurred by BUYER in connection therewith, arising from infringement of patents, copyrights, trademarks or misappropriation of designs.

5. Returns and Cancellations

There will be a 20% cancellation charge for all capital equipment orders.

No returns will be accepted without an authorization number from Carlisle Customer Service. An authorization number may be obtained by calling 800 654 8210 and requesting a Return Authorization from Customer Service. All requests for return must occur within 90 days of the original shipment of the product unless special authorization is obtained. Merchandise returned without authorization will be refused and returned to the customer, freight collect. Any merchandise must be returned freight prepaid, and is subject to a minimum of 20% restocking charge.

All returned goods must reference the original invoice and purchase order. Returned goods must be in original standard packs and in unused salable condition.

Special Order Products and discontinued items will not be accepted for exchange or return. This includes any articles custom imprinted or modified for purchaser.

6. General

- a. All prices are list and subject to change without notice. Orders from authorized accounts will be accepted with the understanding that prices are those in effect at the time of shipment. These prices are exclusive of all sales taxes which may be levied by State, Federal, or City governments.
- b. Orders less than \$100.00 net will be charged a \$10.00 handling fee. The initial order requirement for a new customer is \$3,500 net, and must be accompanied by a tax exemption certificate.
- c. Orders calling for less than a standard case pack will be automatically increased to next full case.
- d. Orders requiring 3rd party freight billing will be assessed a \$5.00 per order processing charge.
- e. All orders of custom products are subject to shipment of plus or minus 10% of the quantity ordered.
- f. No ITEMS to be furnished hereunder shall be exported by BUYER unless SELLER is first notified in writing of the intention to so export and all applicable regulations and licenses are complied with and obtained by BUYER or its customer.
- g. SELLER hereby certifies that the goods described herein of its manufacture will be produced in compliance with all applicable requirements of Sections 6, 7 and 12 of the Fair Labor Standards Act, as amended, and all order of the United States Department of Labor issued under Section 14 thereof. SELLER further certifies that it is in compliance with the Equal Employment Opportunity clause in Section 202, paragraphs 1 through 7 of Executive Order 11246, as amended, relative to equal employment opportunity and the implementing Rules and Regulations of the Office of Federal Contract Compliance.
- h. SELLER is not responsible for typographical errors made in any of its publications or for stenographic or clerical errors made in preparation of quotations, sales orders, acknowledgments, or invoices. All such errors are subject to correction.
- i. This agreement shall be governed by the laws of the state of Oklahoma.
- j. SELLER'S "Terms and Conditions" as set forth above shall govern all transactions. Any inconsistent terms of BUYER wherever set forth and whether oral or written, shall not be binding upon SELLER unless agreed to by SELLER in writing. No waiver or exception to any of the hereinabove enumerated conditions or any of the special terms and provisions relating to any order shall be binding upon SELLER unless agreed to in writing by SELLER.
- k. SELLER reserves the right to change or discontinue the color, design, component content or price of any ITEMS in SELLER'S catalog or published price lists without prior notice at any time.

The specifications and prices listed in this document are subject to change. Carlisle does not assume responsibility for typographical errors.

REV5/14

DINEX



 **APPENDIX A**
Bisphenol A (BPA)

WARNING: This product can expose you to chemicals including Bisphenol A (BPA), which is known to the State of California to cause birth defects or other reproductive harm.

For more information go to www.P65Warnings.ca.gov.

 **APPENDIX B**
Di(2-ethylhexyl)phthalate (DEHP)

WARNING: This product can expose you to chemicals including Di(2-ethylhexyl)phthalate (DEHP), which is known to the State of California to cause birth defects or other reproductive harm.

For more information go to www.P65Warnings.ca.gov.

 **APPENDIX C**
Styrene

WARNING: This product can expose you to chemicals including Styrene, which is known to the State of California to cause birth defects or other reproductive harm.

For more information go to www.P65Warnings.ca.gov.



CFSBRANDS.

www.cfsbrands.com

©2019 CFS Brands
4711 East Hefner Road
Oklahoma City, OK 73131
Phone: 405.475.5600 | 800.654.8210
Toll Free Fax: 800.872.4701
Printed in USA

CAT2019DNX