

BLAST CHILLER / SHOCK FREEZER

Item Number

DXDBC30



Item Number: DXDBC30



Application

This compact unit has a self-contained air-cooled refrigeration system and is complete with all required controls and accessories. The microprocessor control system provides a choice of operating cycles. Automatic or Manual which can be programmed for soft chilling, hard chilling and shock freezing. A core temperature probe is provided for accurate control of temperature within the product. Capacity is three (3) 12" x 20" x 2-1/2" deep food pans.

Construction

This Blast chilling cabinet is constructed of polished 304 Stainless Steel with 1-1/2" of CFC-free high density polyurethane insulation. The interior panels have a mirror finish and interior bottom corners are fully rounded. The door is equipped with a removable magnetic gasket. The door is hinged on operator's left. All motors are sealed ball bearing wash-down type. A 6' long three wire cord set with a NEMA 5-15P plug is provided.

Refrigeration System

The self-contained refrigeration system includes a condensing unit using R-404A refrigerant. The evaporator temperature range is +25°F to -40°F. The compressor is a hermetic type with inherent overload protection.

Performance

Blast chilling (soft or hard) lowers the food core temps from 160°F to 38°F in less than 2 hours. Shock freezing lowers the food core temps from 160°F to 0°F in less than 4 hours. Chilling/freezing times will vary somewhat depending on the food quality, initial temperature, density, moisture content, specific heat, and type of containers. The airflow has a high velocity, indirect pattern designed to cool all levels at identical rates. Time/temps chilling and freezing rates meet or exceed all FDA and state regulations.

Microprocessor Control System

The solid state electronic control panel is user friendly, easy to reach and can be set for automatic or manual operation. The core probe continuously measures the product temperature during the chilling or freezing cycles. Easy to read VFD display and buzzer alarm are

standard features. All settings are programmable by the operator. Both Automatic Mode and Manual Mode can be programmed for:

- **Soft Chilling:** The air temp is held in the range of 28°F to 35°F. Ideal for delicate foods. The chilling cycle is complete when the food core temp reaches 38-40°F.
- **Hard Chilling:** The air temp is lowered to 0°F. When the food core temp reaches 60°F the air temp rises to a range of 28-35°F. The chilling cycle is complete when the food core temp reaches 38-40°F.
- **Shock Freezing:** Shock freezing cycle is engineered to avoid damage to the food structure, keeping the food free of large ice crystals. The air temp is lowered to and held at -25 degrees. The freezing cycle is complete when the food core temp reaches 0°F.
- **Holding:** At the end of any cycle the unit will automatically switch to a holding mode which will keep food at 38°F (chilled) or at 0°F (frozen) until START/STOP button is pressed to end the cycle. If the door is opened before pressing start/stop button, the holding mode will resume when the door is closed and continue until START/STOP button is pressed.

Options

6" high s/s legs are standard extra heavy duty 4" diameter casters 2-w/brakes are optional.

Warranty

One year parts and labor.

DINEX[®]

Building 2, Suite 106
628 Hebron Avenue
Glastonbury, CT 06033
800.523.9752 Fax: 860.652.3135
www.dinex.com

BLAST CHILLER / SHOCK FREEZER

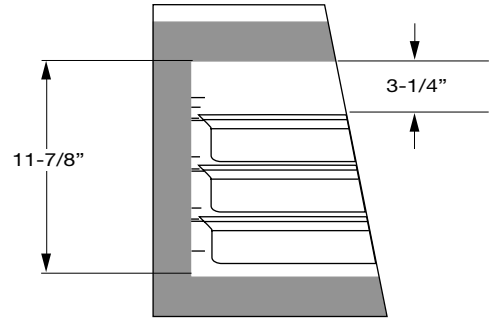
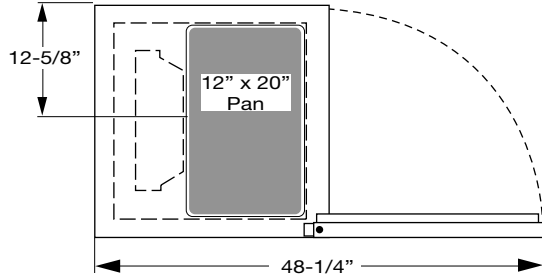

Compartment Section

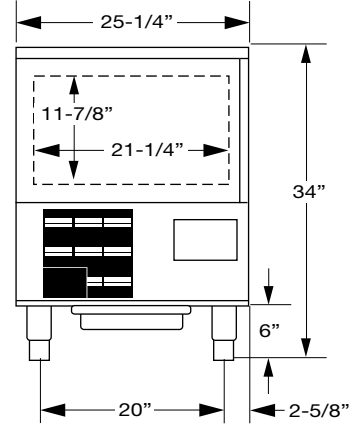
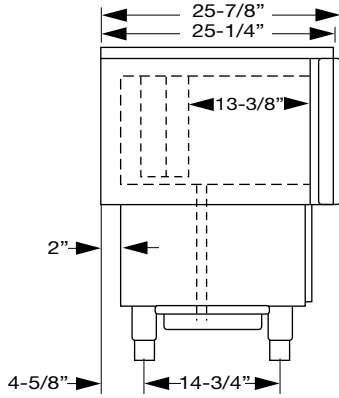

ANSI/NSF 7



Items and Dimensions

	OUTSIDE			INSIDE			DEPTH WITH DOOR OPENED	SHIP WEIGHT
	LENGTH	DEPTH	HEIGHT	LENGTH	DEPTH	HEIGHT		
English	25.25"	25.875"	34"	21.25"	13.375"	11.875"	48-3/4"	192 lb. (81kg)
Metric (cm)	64.1	65.7	86.4	54.0	34.0	30.2	123.8	

ITEM NUMBER	MODEL NUMBER	MAXIMUM LOAD PER CYCLE (LBS)		ELECTRICAL TOTAL					COMPRESSOR HP
		CHILL	FREEZE	VOLTS	PH.	HZ.	AMPS	NEMA	
DXDBC30	DBC30	30 lb.	18 lb.	120	1	60	10.0	5-15P	3/4



Please confirm that you have the most current specification sheet by visiting www.dinex.com.
 Dinex® reserves the right to change specifications and product design without notice.
 Such revisions do not entitle the buyer to corresponding changes, improvements, additions or replacements for previously purchased equipment.



Building 2, Suite 106
 628 Hebron Avenue
 Glastonbury, CT 06033
 800.523.9752 Fax: 860.652.3135
www.dinex.com