

COLD FOOD COUNTER

DineXpress®



Counter options and laminate panels available. Stainless steel panels standard.

Application

These DineXpress Cold Food Counters will help you present your food. The versatile modular design allows you to custom design either a cafeteria or a buffet unit to fit your line-up, choosing only the options and accessories that you want and need. DineXpress units are compatible and will interlock with other DineXpress units.

Construction

General: Units have a 16-gauge 300 series stainless steel top with 1-1/2" turn down on all sides.

Front and end panels are constructed of 18-gauge stainless steel. These panels can be removed without use of tools.

The Cold Food Counters have 5" deep well and a 1" drain with a shut-off valve. The stainless steel pan is separated from the top by means of full perimeter plastic breaker strips.

Corner Posts: The corner posts are constructed of 14-gauge stainless steel.

Casters: The unit is mounted on 5" diameter, heavy duty, non-marking swivel casters, 2 are fitted with brakes.

Cold Storage Optional System: The under-counter can include a 1/3 or 1/2 condensing unit. The refrigerant is type 134A. This design assures that food temperatures are always at the safe level.

Electrical: 120 volt, 1-phase with a 10' cord and NEMA 5-15P plug, on base unit only.

Item Numbers

Non Refrigerated Ice Wells

- DXDCF2NR
- DXDCF3NR
- DXDCF4NR
- DXDCF5NR
- DXDCF6NR

Mechanical Refrigeration

- DXDCF2
- DXDCF3
- DXDCF4
- DXDCF5
- DXDCF6

Options

- Tray slides
- Food protector guards
- Drop down work shelf
- In base cold storage system
- Formica laminate panels
- Duplex outlets
- Acrylic tops
- Engineered stone tops
- Hinged doors
- Intermediate undershelf
- Skirting
- Over head shelf
- Legs in lieu of casters

Warranty

One year parts and labor.

DINEX®

Building 2, Suite 106
628 Hebron Avenue
Glastonbury, CT 06033
800.523.9752 Fax: 860.652.3135
www.dinex.com

404-REV 01/10

COLD FOOD COUNTER

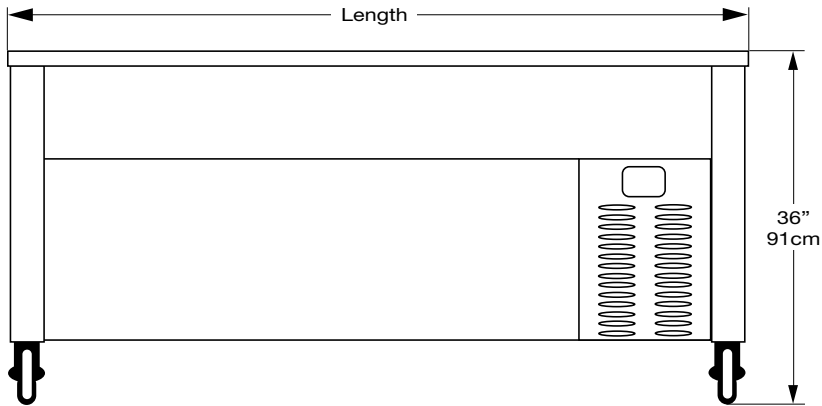

Front View

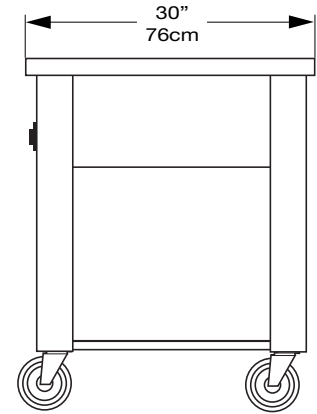

Side View



Items and Dimensions

| ITEM NUMBER | MODEL NUMBER | SHIP WEIGHT | SHIP CUBE | LENGTH | DEPTH | HEIGHT | HP | VOLTS | NEMA NUMBER |
|-------------|--------------|----------------------|-----------|----------------|---------------|---------------|-----|-------|-------------|
| DXDCF2 | DCF/2 | 390 lb. (177.1kg) | 15.6 | 35" (89cm) | 30" (76cm) | 36" (91cm) | 1/3 | 120v | 5-15P |
| DXDCF2NR | DCF/2NR | 290 lb. (131.7kg) | | | | | - | - | - |
| DXDCF3 | DCF/3 | 430 lb. (195.2kg) | 23.8 | 49" (125cm) | 30" (76cm) | 36" (91cm) | 1/3 | 120v | 5-15P |
| DXDCF3NR | DCF/3NR | 330 lb. (149.8kg) | | | | | - | - | - |
| DXDCF4 | DCF/4 | 470 lb. (213.4kg) | 29.9 | 63" (160cm) | 30" (76cm) | 36" (91cm) | 1/3 | 120v | 5-15P |
| DXDCF4NR | DCF/4NR | 370 lb. (168.0kg) | | | | | - | - | - |
| DXDCF5 | DCF/5 | 510 lb. (231.5kg) | 36.2 | 77" (196cm) | 30" (76cm) | 36" (91cm) | 1/2 | 120v | 5-15P |
| DXDCF5NR | DCF/5NR | 410 lb. (186.1kg) | | | | | - | - | - |
| DXDCF6 | DCF/6 | 555 lb. (252.0kg) | 42.4 | 91" (231cm) | 30" (76cm) | 36" (91cm) | 1/2 | 120v | 5-15P |
| DXDCF6NR | DCF/6NR | 450 lb. (204.3kg) | | | | | - | - | - |

Note: Electrical specifications are for the base model only and subject to change pending options specified.



Please confirm that you have the most current specification sheet by visiting www.dinex.com.
Dinex® reserves the right to change specifications and product design without notice.
Such revisions do not entitle the buyer to corresponding changes, improvements, additions or replacements for previously purchased equipment.

Printed in USA



Building 2, Suite 106
628 Hebron Avenue
Glastonbury, CT 06033
800.523.9752 Fax: 860.652.3135
www.dinex.com

404-REV 01/10