

HEATED CABINET



Application

The Heated Cabinet is perfect for maintaining temperatures. This cabinet is capable of heating up to 200°F. Even heat distribution is assured by a high-performance blower fan and a 1,600 watt element.

Construction

Completely welded cabinet construction and top corners, with outer cabinet formed to base and welded. All seams turned in to eliminate raw edges. Exterior wall are 20-gauge stainless steel and interior are be 24-gauge. Base frame is 12-gauge stainless steel full depth bolsters with 1" x 1" 14-gauge stainless steel perimeter tube supports welded to bolsters.

Doors

Double panel welded stainless steel door with heavy duty vinyl gasket. 20-gauge polished exterior and 24-gauge interior filled with 1" thick high density fiberglass insulation.

Hinges

Hinges are concealed stainless steel with 5/16" pins.

Push Handles

Two heavy duty aluminum push handles mounted on each end of cabinet.

Bumper

Non marking black vinyl bumper set in heavy duty 3/16" thick extruded aluminum frame with reinforced corner cut outs.

Tray Slides

Tray slides are 16-gauge stainless steel and universal with 18-gauge stainless steel rack post.

Heating System

Bottom mounted heater is removable without tools. Cabinets have a full range thermostat with power indicating light. Operates on 120 volt with 1650 watts.

Item Numbers

- DXHC20
- DXHC24

Standard Features

- 6" Performa Casters 2 with brakes
- Wheel ahead caster pattern
- 2 aluminum push handles
- Adjustable universal tray slides

Options

- Menu card holder
- Top mounted transport latch
- Stainless steel push handles
- Additional slides

Warranty

One year parts and labor.

We do not accept returns on any Dinex equipment or Dinex custom products. Please contact your local Dinex rep to ensure order accuracy prior to ordering.

DINEX[®]
A **CARLISLE** COMPANY

4711 E Hefner Road
Oklahoma City, OK 73131
800.654.8210 • 405.475.5600
www.dinex.com

HEATED CABINET

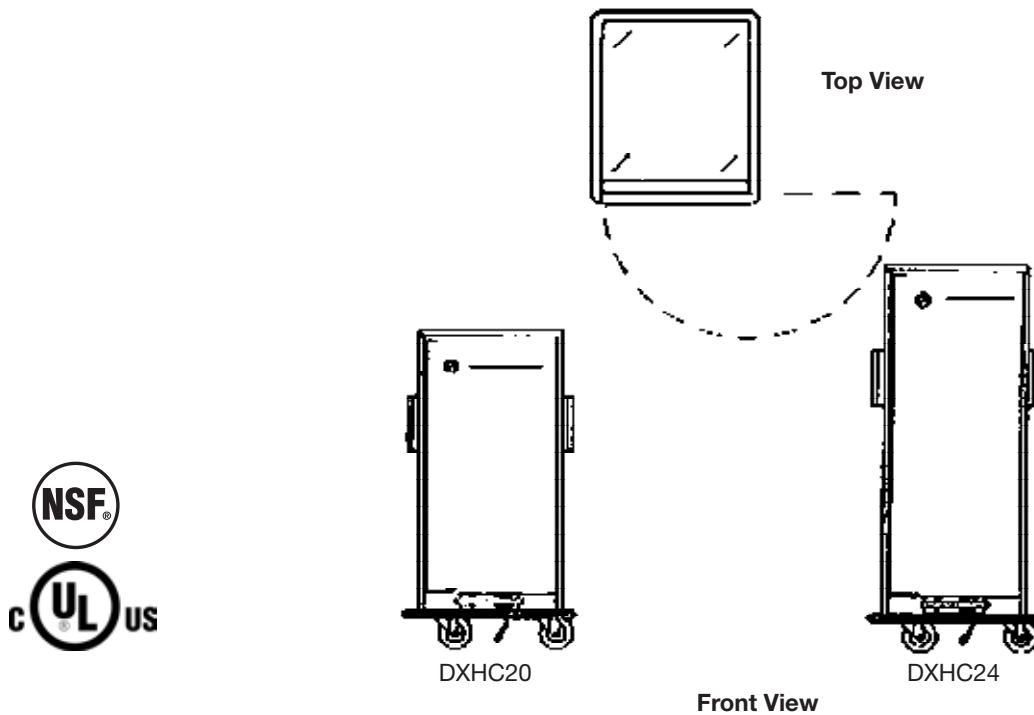

Items and Dimensions

ITEM NUMBER	MODEL NUMBER	LENGTH	DEPTH	HEIGHT	SLIDE PAIRS STANDARD	MAXIMUM PAN/TRAY SIZE CAPACITY		SHIP WEIGHT	SHIP CUBE
						18" x 26"	12" x 20"		
DXHC20	HC20	30.625" (77.8cm)	36" (91.4cm)	58" (147.3cm)	10	12	24	305 lb. (138.5kg)	36.8
DXHC24	HC24	30.625" (77.8cm)	36" (91.4cm)	71" (180.3cm)	12	16	32	350 lb. (158.9kg)	45.1

Electrical

VOLTS	WATTS	AMPS	NEMA NUMBER
120	1650	13.7	5-15P

Please confirm that you have the most current specification sheet by visiting www.dinex.com.
 Dinex® reserves the right to change specifications and product design without notice.
 Such revisions do not entitle the buyer to corresponding changes, improvements, additions or replacements for previously purchased equipment.