

MOBILE TRAY DISPENSERS



Item Numbers

Single

- DXIDT1S1418
- DXIDT1S1520
- DXIDT1S1622

Double

- DXIDT2S1418
- DXIDT2S1520
- DXIDT2S1622

Application

These self-leveling mobile tray dispensers are offered in two styles: Single stack, tubular frame with solid bottom, and double stack, tubular frame with solid bottom. These self-leveling mobile tray dispensers can be found in tray lines, in the front or back-of-the-house, or any place your needs require.

Construction

The lifting mechanism is constructed of type 304 stainless steel with all exposed parts having a No. 4 finish. The Mobile Tray Dispenser is equipped with self-lubricating delrin wheels and a full complement of stainless steel extension springs which can be easily disconnected to adjust the lifting rate.

A removable stainless steel carrier tray provides bottom support for trays being dispensed.

The base is fabricated of stainless steel and reinforced with 16-type 304 stainless steel angles. The tubular frames are fabricated from 16-gauge stainless steel tubing and securely welded to stainless steel angles on underside of base. The tubular frames are reinforced by horizontal 3/8" diameter type 304 stainless steel rods welded to each vertical frame. Four 5" heavy-duty non-marking swivel casters (2 with brakes) are securely mounted to the base and a non-marking bumper is attached at each corner.

Standard Features

- Stainless steel construction including stainless steel extension springs for long lasting dependable service.
- Patented self-leveling mechanism lifts out for easy cleaning.
- Field adjustable to accommodate different weights.
- Corner Bumpers

Warranty

One year parts and labor.

DINEX®

Building 2, Suite 106
628 Hebron Avenue
Glastonbury, CT 06033
800.523.9752 Fax: 860.652.3135
www.dinex.com

039-REV 01/10

MOBILE TRAY DISPENSERS

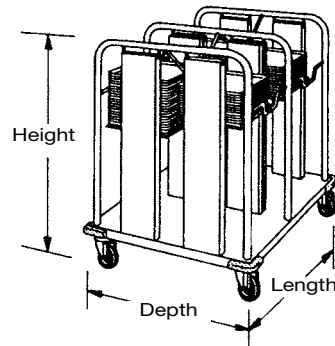
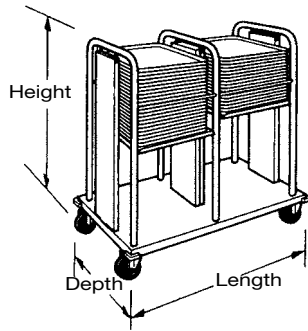

Items and Dimensions

ITEM NUMBER	MODEL NUMBER	LENGTH	DEPTH	HEIGHT	CASTERS		MAXIMUM TRAY SIZE	SHIP WEIGHT	SHIP CUBE
					TYPE	DIA.			
DXIDT1S1418	IDT1S/1418	18.6875" (47.5cm)	21.875" (55.6cm)	36.25" (92.1cm)	4 Swivel 2 w/brakes	5"	14.375" x 18.75" (36.5cm x 47.6cm)	133 lb. (60kg)	9.8
DXIDT1S1520	IDT1S/1520	19.6875" (50.0cm)	23.875" (60.6cm)	36.25" (92.1cm)	4 Swivel 2 w/brakes	5"	15.375" x 20.75" (39.1cm x 52.7cm)	133 lb. (60kg)	9.8
DXIDT1S1622	IDT1S/1622	20.6875" (52.5cm)	25.875" (65.7cm)	36.25" (92.1cm)	4 Swivel 2 w/brakes	5"	16.375" x 22.75" (41.6cm x 57.8cm)	138 lb. (63kg)	12.8
DXIDT2S1418	IDT2S/1418	36.5625" (92.8cm)	21.875" (55.6cm)	36.25" (92.1cm)	4 Swivel 2 w/brakes	5"	14.375" x 18.75" (36.5cm x 47.6cm)	152 lb. (69kg)	19.1
DXIDT2S1520	IDT2S/1520	38.5625" (97.9cm)	23.875" (60.6cm)	36.25" (92.1cm)	4 Swivel 2 w/brakes	5"	15.375" x 20.75" (39.1cm x 52.7cm)	170 lb. (77kg)	22.0
DXIDT2S1622	IDT2S/1622	40.5625" (103.0cm)	25.875" (65.7cm)	36.125" (92.1cm)	4 Swivel 2 w/brakes	5"	16.375" x 22.75" (41.6cm x 57.8cm)	174 lb. (78kg)	25.1



Please confirm that you have the most current specification sheet by visiting www.dinex.com.
 Dinex® reserves the right to change specifications and product design without notice.
 Such revisions do not entitle the buyer to corresponding changes, improvements, additions or replacements for previously purchased equipment.

Printed in USA



Building 2, Suite 106
 628 Hebron Avenue
 Glastonbury, CT 06033
 800.523.9752 Fax: 860.652.3135
www.dinex.com

039-REV 01/10