



**Project:**  
**Item Number:**  
**Quantity:**

**MIRAGE® PRO COUNTERTOP INDUCTION RANGE**



**DESCRIPTION**

The ultra-low profile, portable countertop induction range is designed for use in light to medium duty front-of-the-house cooking.

The induction ranges are equipped with a variety of safety features including:

- Over-heat protection
- Small-article detection
- Pan auto-detection function
- Empty-pan shut-off
- Safety auto-shut-off function

**AGENCY LISTINGS**

**59500P**



This device complies with Part 18 FCC Rules.

**59510P**



This device complies with Part 18 FCC Rules.

**ITEMS**

- 59500P Countertop Induction Range, 1800 Watts (US only)
- 59510P Countertop Induction Range, 1400 Watts (US and Canada)

**FEATURES**

- 1-100 power levels and °F/°C temperature control
- 90% efficiency rating
- 1-180 minute timer
- The case frame is made from heavy-duty, 18-gauge stainless steel with a ceramic top
- Variable speed knob for fast temperature adjustment
- Range display HOT when unit is turned off, if the cooking surface is still hot
- Rubber feet to prevent slipping of appliance
- 6 ft. (183 cm) power cord with plug.

**WARRANTY**

Two year parts and labor. See Vollrath.com for full warranty details.

**CLEARANCE AND ENVIRONMENT REQUIREMENTS**

- This appliance is intended for use with induction-ready cookware. It is not intended to be used with aluminum pans with a metal disk on the bottom.
- All models require adequate unrestricted intake and exhaust air ventilation for proper operation of the controls. The maximum intake temperature must not exceed 110°F (43°C). Temperatures are measured in ambient air while all appliances in the kitchen are in operation.
- Countertop models require a minimum clearance of 4 inches (10.2 cm) at the rear and 1 inch (2.5 cm) at the bottom.

Due to continued product improvement, please consult [www.vollrath.com](http://www.vollrath.com) for current product specifications.

Approvals	Date



[www.vollrath.com](http://www.vollrath.com)

**The Vollrath Company, L.L.C.**

1236 North 18th Street  
 Sheboygan, WI 53081-3201 U.S.A.  
 Main Tel: 800.624.2051 or 920.457.4851  
 Main Fax: 800.752.5620 or 920.459.6573  
 Customer Service: 800.628.0830  
 Canada Customer Service: 800.695.8560

Technical Services  
[techservicereps@vollrathco.com](mailto:techservicereps@vollrathco.com)  
 Induction Products: 800.825.6036  
 Countertop Warming Products: 800.354.1970  
 All Other Products: 800.628.0832

# MIRAGE® PRO COUNTERTOP INDUCTION RANGE

## DIMENSIONS (Shown in inches (cm))

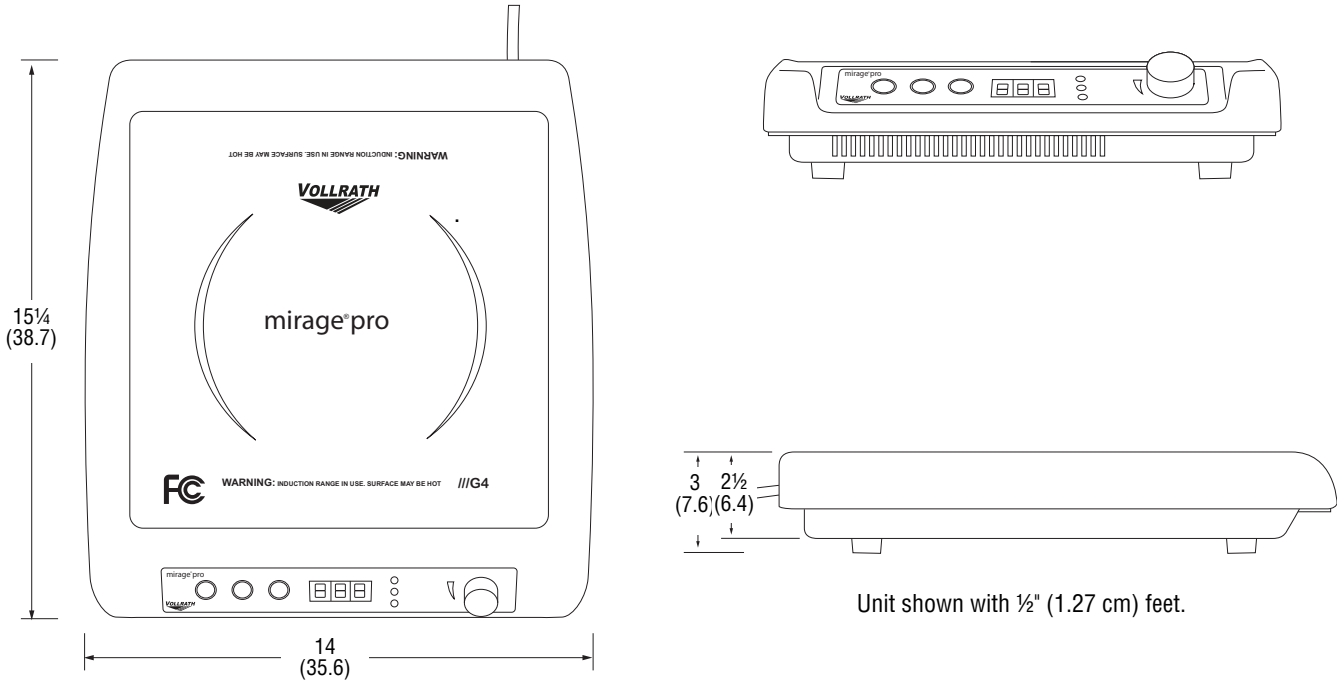

## SPECIFICATIONS

Item No.	Max Pan Diameter* IN (CM)	Watts	Volts	Amps	Phase	Hz	Plug	Weight LB (KG)
59500P	14	1800	120	15	Single	60	NEMA 5-15P	12.8
59510P	(35.6)	1400		12				(5.8)

\* Maximum pan diameter is provided as a guideline for achieving maximum performance. Other factors impact performance including pan construction material, the density and volume of the food in the pan, ambient temperature and food temperature.

### Receptacle

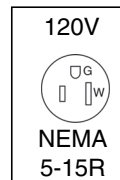

[www.vollrath.com](http://www.vollrath.com)

**The Vollrath Company, L.L.C.**  
 1236 North 18th Street  
 Sheboygan, WI 53081-3201 U.S.A.  
 Main Tel: 800.624.2051 or 920.457.4851  
 Main Fax: 800.752.5620 or 920.459.6573  
 Customer Service: 800.628.0830  
 Canada Customer Service: 800.695.8560

Technical Services  
[techservicereps@vollrathco.com](mailto:techservicereps@vollrathco.com)  
 Induction Products: 800.825.6036  
 Countertop Warming Products: 800.354.1970  
 All Other Products: 800.628.0832