



Cast Iron Panini Grill Series 20" Panini Grill

ITEM # _____

MODEL # _____

PROJECT NAME # _____

SIS # _____

AIA # _____



Cast Iron Panini Grill Series 20" Panini Grill

- 602113 (DGR20) 20" Panini Grill, ribbed/ribbed
220 V/1p/60Hz
- 602114 (DGS20) 20" Panini Grill, ribbed/smooth
220 V/1p/60Hz
- 602115 (DGM20) 20" Panini Grill, ribbed/mixed
220 V/1p/60Hz
- 602116 (DGSS20) 20" Panini Grill, smooth/smooth
220 V/1p/60Hz

Short Form Specification

Item No. _____

Unit to be Electrolux Dito 20" Panini Grill. Electrical characteristics to be 220 V SINGLE-phase operation. Thanks to its small size, it is easy to handle and to position, offering as well a large 20" cooking surface. It is available in two versions: plate L (smooth) and plate R (ribbed) and mixed surface.



Approval: _____

Main features

- Available in 4 different versions:
 - top and bottom ribbed surface.
 - top and bottom smooth surface.
 - top ribbed surface and bottom half smooth and half ribbed surface.
 - top ribbed surface and bottom smooth surface.
- Cast iron plates are covered by a vitreous enamel coating, making them scratch and rust proof and ensuring hygiene. They are acid and salt proof and resistant to oxidation.
- Stainless steel 430 construction
- Shock-proof heating elements 3.0 kW
- Mounted inside the plate for a perfect thermal conductivity
- Adjustable thermostat up to 570 °F
- Adjustable Timer built-in
- Self-balancing upper plate adjusts to different heights to halve cooking times and double performance.
- Made of Stainless steel AISI 430 and the cooking surface is made of a special cast iron treated with verified food enamel, this guarantees hygienic conditions and high resistance to acids, salts and oxidation processes.
- Dimensions: (HxLxW): 6.69" x 10" x 20.5"
- Approx. shipping weight—71 lbs
- ETL electrical and ETL sanitation listed. ETL Canada.
- NEMA # : 6-20P
- 2 year parts warranty, 1 year labor.
- Cooking Surface Dimensions: 10" x 20.5"
- Top Plate shut-off switch standard.



Cast Iron Panini Grill Series
20" Panini Grill

Electrolux Professional, Inc.

www.electroluxusa.com/professional

3225 SW 42nd Street, Fort Lauderdale, Florida, 33312 • Telephone Number: 866-449-4200 • Fax Number: 954-327-6789

Front View

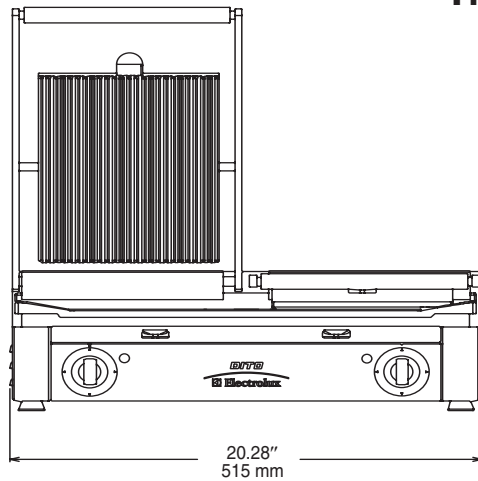

Top View

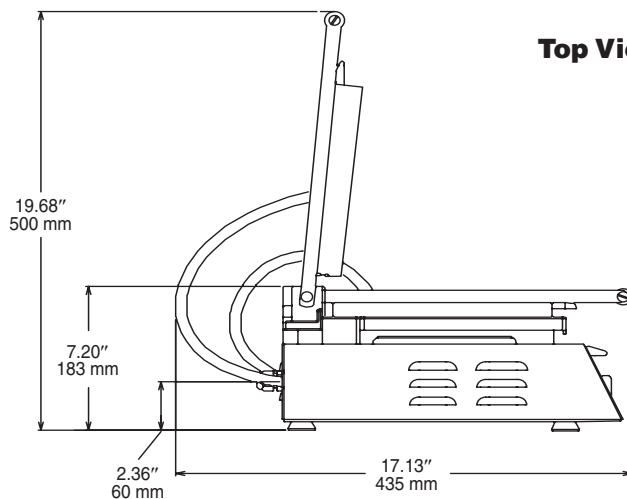

EC = Electrical connection

Side View

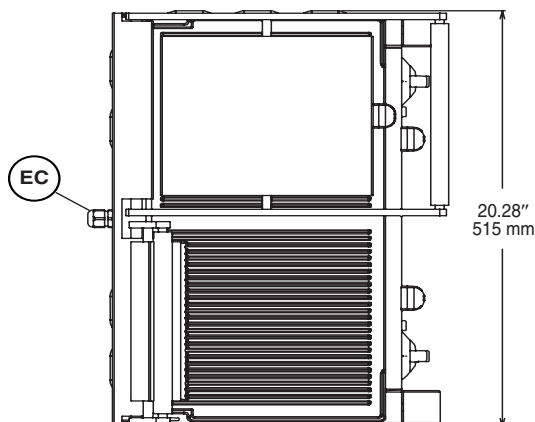

Electric

Supply voltage:

602113 (DGR20)	220 V/1p/60Hz – 16A
602114 (DGS20)	220 V/1p/60Hz – 16A
602115 (DGM20)	220 V/1p/60Hz – 16A
602116 (DGSS20)	220 V/1p/60Hz – 16A

Key Information

FIRST USE OF THE MACHINE

- When the machine is delivered, the steel surfaces are protected with a nylon anti-scratch film. This film has to be removed.
- The insulating materials used during the manufacturing and the residuals of grease due to the mechanical installation of single parts, heat and produce smoke, for this reason, **it is necessary to start the machine at maximum temperature for 15-20 minutes.**

GENERAL CLEANING

- Clean the Grill at least once a day and, if necessary more often.
- All the machine parts that are in contact with the product must be cleaned.
- Never clean the machine by means of compressed water or water jets.
- Cleaning can be performed when surface is hot, scrape with a metallic brush on the cooking grid several times.
- Empty the grease tray.
- It is advisable to perform these cleaning operations when the Grill temperature is at the minimum so that the residual grease that sticks to the grid can melt.
- Do not pour water or other liquids on the Grill when it is hot, because the changes of temperature can provoke their breaking.