

Electrolux

DITO

K120 Vertical Cutter-Mixer

ITEM # _____

MODEL # _____

PROJECT NAME # _____

SIS # _____

AIA # _____

Electrolux
DITO



Main features

- Power: 3 HP for Two Speed Model, and 3 HP for Variable Speed Model
- 1800/3600 RPM for Two Speed Model, and 300-3600 RPM for Variable Speed Model.
- 2.2 kW for Two Speed Model, and 2.2 kW for Variable Speed Model.
- Red OFF, Green ON, and PULSE Buttons
- Compact Design
- Belt Drive
- All Stainless Steel Bowl
- Magnetic safety system and motor brake. Prevents machine from running when bowl lid swings away from magnetic switch or is open.
- Delivered with :
 - 12.2 Qt. Stainless Steel bowl with smooth edge "S" blade included.
 - Complete selection of accessories available.
 - Dimensions: (HxLxW): 20.4" x 16.4" x 26.75"
 - Approx. shipping weight—128 lbs
 - NEMA L15-20P for Two Speed Model, and NEMA 6-20P for Variable Speed Model.
 - 2 year parts warranty, 1 year labor.

Included Accessories:

- Smooth Blade Rotor - 12.2 Qt. VCM (PNC 653179)
- 12.2 Qt. Stainless Bowl (PNC 653270)

Optional Accessories:

- Smooth Blade Rotor - 12.2 Qt. VCM (PNC 653179)
- Serrated Blade Rotor - 12.2 Qt. VCM (PNC 653299)
- Equipped Scraper for 12.2 Qt. VCM (PNC 653277)
- 12.2 Qt. Stainless Bowl (PNC 653270)
- Stainless Steel Mobile Stand (PNC 653017)

K120 Vertical Cutter-Mixer

- 603297 (K120FU)** K120 VCM (s/s bowl) 2 SPEED 208-240 V/3p/60Hz
- 603309 (KE120FU)** K120 VCM (s/s bowl) Variable SPEED 208-240 V/1p/50/60Hz

Short Form Specification

Item No. _____

Unit to be Electrolux Dito K120FU or KE120FU K120 Vertical Cutter-Mixer. Electrical characteristics to be 208-240 V, Three-phase operation with 2 speed at 1800 or 3600 rpm or to be 208-240 V, Single -phase operation with Variable speeds at 300-3600 rpm. Vertical Cutter-Mixer designed for vertical cutting and mixing in 12.2 quart quantities: puree, mix, chop, blend, mix and knead dough.



Approval: _____

K120 Vertical Cutter-Mixer

Electrolux Professional, Inc.

www.electroluxusa.com/professional

3225 SW 42nd Street, Fort Lauderdale, Florida, 33312 • Telephone Number: 866-449-4200 • Fax Number: 954-327-6789

Front View

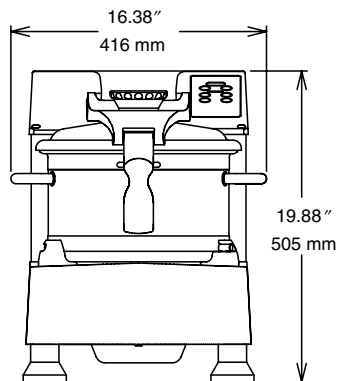

Side View

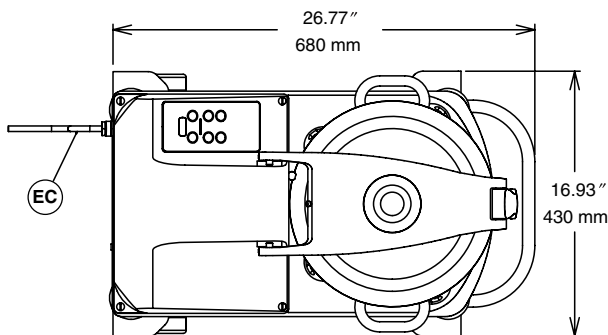

EC = Electrical connection

Top View

(Shown with optional trolley.)

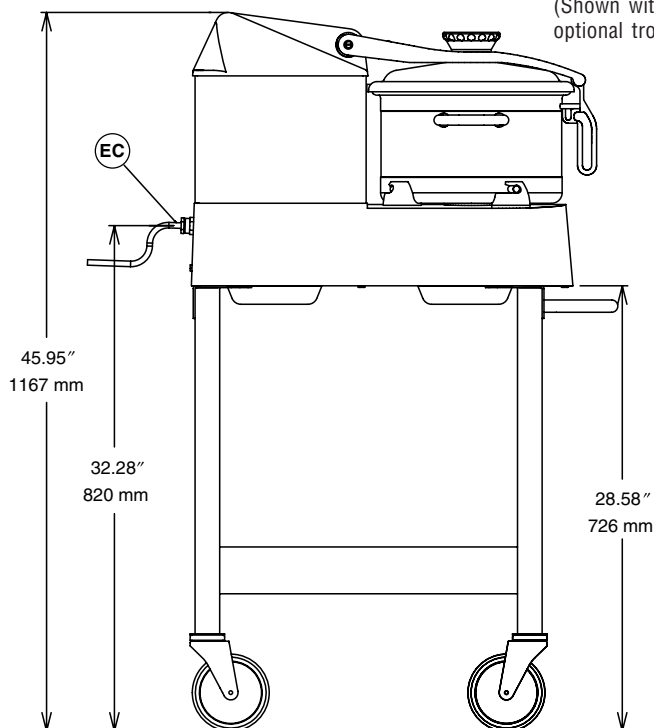

Electric

Supply voltage:

603297 (K120FU) 208-240 V/3p/60Hz – 15A

603309 (KE120FU) 208-240 V/1p/50/60Hz – 15A

Key Information

Uses of Food Processor

MEAT

Rough mincing

Pates

Small sausages

Large sausages

Minced meat

Shellfish

Fine mincing

Stuffing

Mousses

PASTRY

Shortcrust

Cold water paste

Flan

POWDER

Almonds

Hazelnuts

FRUITS AND VEGETABLES

Purees

Mousses

Syrups

CHOPPING

Parsley

Onions