



PROVEYOR® CONVEYOR OVENS

Model 314HX and 318HX

Features/Benefits:

- Holman's Proveyor® ovens are designed to cook a variety of menu items such as fresh dough pizza, blanched pizza, subs, cookies, fish and more quick and easy while preserving cooking space.
- Quartz Infrared Heaters provide faster more consistent heating than traditional heating elements. Elements are located above and below conveyor belt allowing precise even heating of products.
- Patented forced convection system keeps the conveyor oven cool to the touch and extends the life of critical components. The forced convection increases productivity by recirculating preheated air into the cooking chamber.
- Conveyor belt speed control and top & bottom heat control enables different menu items to be baked on the same oven providing superior flexibility.
- Ovens can be stacked one, two or three high with our stacking spacer to conserve cooking space.
- Product entry and exit openings are adjustable from 1-1/2" to 4" high allowing space for a variety of menu items.
- Removable extended load/unload area for ease of product removal.
- Removable crumb tray for fast and easy clean-up.
- 24/7/365 - 24 hours a day/7 days a week/365 days a year technical support by Holman technicians.



Capacity:

- Fresh dough pizza production of Proveyor Conveyor Ovens:
 #314HX - 14-16 12" pizzas/hr, 56-60 5" pizzas/hr
 #318HX - 10-12 16" pizzas/hr, 14-16 12" pizzas/hr, 90-110 5" pizzas/hr

Applications:

Holman's Proveyor® ovens are engineered keeping value and efficiency in mind and designed for you to add a variety of items to your menus. Ideal for sandwich shops, food courts, caterers, kiosks, supermarkets, deli's, restaurants or where ever you want to finish bake quickly, easily and economically.

Quality Construction:

Holman Proveyor® ovens are constructed with all stainless steel for long lasting durability. Heavy-duty motor and drive chain require no lubrication. Stainless steel conveyor belt comes standard traveling from left to right, but can be specially ordered right to left. Ovens are stackable and furnished with 2-1/2" adjustable legs. Stacked ovens must be installed at least 6" from any vertical combustible surface. High performance Quartz Infrared Heaters for superior and reliable cooking performance.

Warranty:

Proveyor® ovens are covered by Holman's one year parts and labor warranty.





PROVEYOR® CONVEYOR OVENS

Model 314HX and 318HX

Proveyor® Ovens

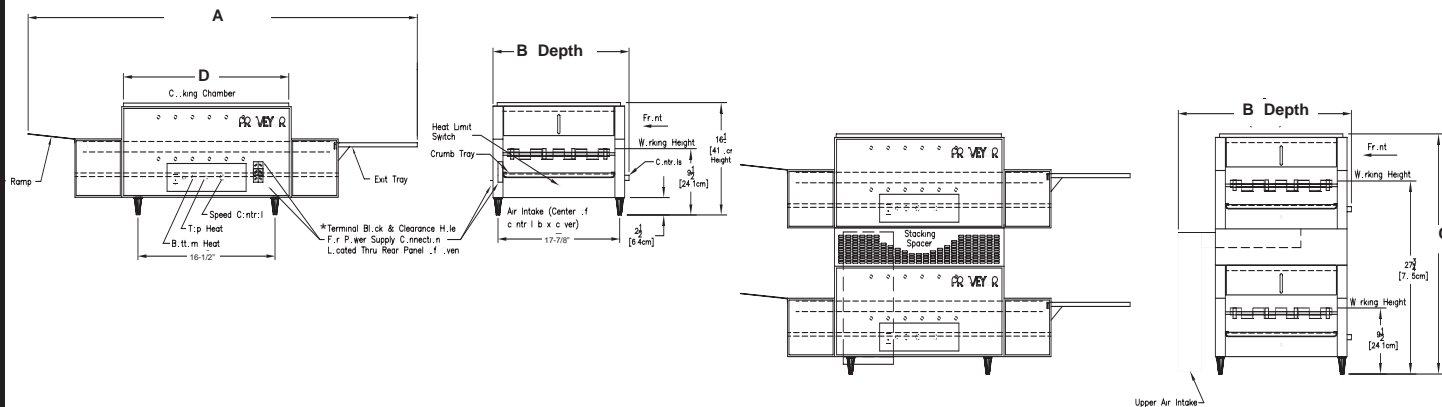

Performance Data

Model No.	Product Opening	Cooking Chamber		*Production Capacities
		Width	Length (D)	
314HX	Adjustable from 1-1/2" to 4"	16" (40.7cm)	21-1/2" (54.6cm)	14-16 12" fresh dough pizzas per hour 56-60 5" fresh dough pizzas per hour
318HX	Adjustable from 1-1/2" to 4"	19-3/4" (50.2cm)	21-1/2" (54.6cm)	10-12 16" fresh dough pizzas per hour 14-16 12" fresh dough pizzas per hour 90-110 5" fresh dough pizzas per hour

Specifications

Model No.	Dimensions			Approximate Weight		Shipping Carton		
	length(A)	Depth(B)	Height(C)	Shipping	Installed	Length	Depth	Height
314HX	60" (152.4cm)	21-1/4" (54 cm)	16-1/8" (40 cm)	115 lbs. (52 kg)	86lbs. (40kg)	47-1/2" (120.7cm)	27" (68.5 cm)	26-3/4" (68 cm)
318HX	60" (152.4cm)	24-7/8" (63.2 cm)	16-1/8" (40 cm)	130 lbs. (59kg)	96lbs. (44kg)	47-1/2" (120.7cm)	27" (68.5cm)	26-3/4" (68 cm)

Electrical Data

Model No.	*HZ	Phase	Volts	Amp	Watts	Heating Elements		NEMA	Cord
						Above	Below		
314HX	60	1/3*	208	25.9/14.9	5400	4	5	6-30P	4' N/A
	60	1/3*	240	22.5/12.9	5400	4	5	6-30P	4' N/A
	50	3	380/220	8.7	5400	4	5	6-30P	N/A
318HX	60	1/3*	208	29.8/17.2	6200	4	5	6-30P	4' N/A
	60	1/3*	240	25.8/14.8	6200	4	5	6-30P	4' N/A
	50	3*	380/220	9.9	6200	4	5	6-30P	N/A

*CE certified, 3 phase, and phase control units shipped with terminal block connections

Typical Specifications

Ovens are constructed of stainless steel. Standard range of belt speeds, internal temperatures and voltage can be modified to meet any requirements. Conveyor belt travels left to right but can be ordered right to left. Single and stacked ovens furnished with 2-1/2" adjustable legs, infrared radiant heaters with fused quartz sheathing and on/off heat switch for heat control are standard. Product opening adjustable from 1-1/2" to 4", motors are permanently lubricated and bearings are long lasting teflon. Units are UL listed, CSA certified and NSF approved. Printed in the U.S.A.

Star Manufacturing International, Inc. - 10 Sunnen Drive - P.O. Box 430129 - St. Louis, MO 63143-3800

Phone: (800) 264-7827 - FAX: (800) 264-6666 - www.star-mfg.com