

Project	Quantity	Item #
Model Specified:		CSI Section 11400

### 50 lb. Capacity Undercounter Blast Chiller Model/Self-Contained



Model RBC50



Model RBC50  
(shown with optional casters)

Like all blast chillers, Traulsen's model RBC50 is designed to quickly cool its respective capacity of hot product through the HACCP danger zone as fast, or faster, than any other equivalent brand on the market (approximately 90-minutes). However, in addition to the outstanding cabinet construction synonymous with Traulsen, what differentiates these models from competition is the operational flexibility and labor savings inherent in their easy-to-use controls, automatic HACCP documentation, and a variety of operator friendly features, such as our exclusive "By-Product" chill mode.

This model is supplied standard with a stainless steel work top, making it an ideal base for other kitchen equipment, such as an oven, in order to form a self-contained production station.

### Exclusive Standard Features

- Easy-to-Use SmartChill® Control System
- One Button EZ-START™ Feature
- Three (3) SmartProbes™ Automatically Register Product Temperatures
- On-Board Label Printer (prints adhesive labels which can be placed directly on to product containers)
- By Product Chill Mode (allows the operator to pre-program into memory the individual chilling requirements of a variety of different food products)

### Options & Accessories

- Set Of Four (4) 6" High Casters
- One or Two Day On-Site Blast Chill Training
- Stainless Steel Finished Back
- Water Cooled Self-Contained Condenser Suitable For Connection To Glycol
- BCACC-60387: SmartChill® PC Communications Software Package
- BCACC-NDPG1: Communications Gateway (required for use within a NAFEM Data Protocol compliant network)
- Two Year Service/Labor Warranty Available

### Other High Quality Standard Features

- Stainless Steel Exterior & Interior Construction
- Stainless Steel Work Top
- Communications Capable & NAFEM Data Protocol Compliant
- On-Board Batch Data Printer
- Three (3) Chilling Functions
  - 1) Blast Chill (135° to below 41°F in approx. 90-minutes)
  - 2) Soft Chill (for use with delicate products such as fresh seafood and produce)
  - 3) Freeze (target temp can be set for as low as -22°F)
- Three (3) Chilling Modes For Each Chilling Functions
  - 1) By Temperature
  - 2) By Product
  - 3) By Time
- Automatic Refrigerated Hold Mode After Each Cycle
- Self-Contained Refrigeration System
- Magnetic Door Gasket
- Self-Closing and Stay Open Door Features
- Stainless Steel Field Rehingeable Door(s) With Locks (hinged right)
- Five (5) Pairs of Tray Slides To Accommodate Five (5) 12" x 20" Steam Table Pans
- Set Of Four (5) 6" High Stainless Steel Legs
- Automatic Defrost With On-Demand Feature
- Automatic Condensate Removal
- Adjustable Product Chill Target Temperatures
- Adjustable Product Holding Temperature
- One Year Parts/Labor Warranty



Listed by Underwriters Laboratories Inc., to U.S. and Canadian safety standards and Listed by NSF International.

Approval: \_\_\_\_\_



TRAULSEN  
4401 BLUE MOUND RD.  
PHONE 1 (800) 825-8220  
Website: www.traulsen.com

FT. WORTH, TX 76106  
FAX-MKTG. 1 (817) 624-4302

Project	Quantity	Item #
Model Specified:		CSI Section 11400

## Specifications

### Construction, Hardware and Insulation

Exterior sides, front, door, work top and interior are constructed of heavy gauge stainless steel. Exterior back and bottom are constructed of heavy gauge aluminized steel. Door is equipped with guaranteed for life cam lift, self-closing hinges with a stay open feature at 120°. A full width metal door handle/gasket guard is provided. Easily removable for cleaning, vinyl magnetic gasket assures tight door seal. Anti-condensate heaters are located behind the door opening. Both cabinet and door are insulated by high density, non-CFC, foamed in place polyurethane.

### Refrigeration System

A high capacity refrigeration system using R-404A refrigerant is coupled with an advanced air circulation system within the food zone in order to promote rapid chilling. It features an easy to clean front facing condenser, thermostatic expansion valve, high speed evaporator fan, air-cooled hermetic compressor, large, high humidity evaporator coil and a non-electric condensate evaporator. A 9' cord and plug is provided. Standard operating temperature in automatic refrigeration mode is 34 to 38°F.

### Controller

The SmartChill™ microprocessor system operates using a familiar "ATM" type interface, providing for ease of training and use. The control allows the chiller to be operated in any one of three different chilling functions, and in any one of three modes. HACCP documentation is facilitated by two on-board printers which record all required product chill cycle information. This same data can also be downloaded to a PC using optional SmartChill™ communications software (available from Traulsen) or via optional NAFEM Data Protocol Compliant hardware and software (by others). An instructional DVD is included.

DIMENSIONAL DATA	RBC50
Net Capacity cu. ft.	9.2 (267 cu l)
Pan Capacity - 12" x 20" x 2 1/2"	5
Product Capacity lbs.	50 - 65 lbs.
Length - Overall in.	54 (137.2 cm)
Depth - Overall in.	34 7/16 (87.4 cm)
Depth - Cabinet only in. Over Body in.	34 (86.4 cm)
Depth - with Door Open 90° in.	58 13/16 (149.4 cm)
Clear Door Width in.	23 (64.8 cm)
Clear Door Height in.	20 7/16 (51.9 cm)
Height - Overall on Casters	33 13/16 (85.6 cm)
ELECTRICAL DATA	
Voltage	115/60/1
Feed Wires with ground	3
Full Load Amperes	13.3
Circuit Ampacity	20
REFRIGERATION DATA - Based on 90°F ambient and 0°F evaporator.	
Refrigerant	R-404A
BTU/HR - HP	4400 (1 HP)

Figures in parentheses reflect metric equivalents

**NOTE:** Unit requires a dedicated, fused circuit & electrical outlet for proper operation.



Equipped With One NEMA 5-15P Plug

**NOTE:** Freight charges are FOB destination for dock to dock delivery within the continental USA. For inside delivery charges please consult factory.

Continued product development may necessitate specification changes without notice.  
Part No. TR35797 (revised 10/12)

### Blast Chill Operation

In Blast Chill mode the high capacity refrigeration system, in conjunction with a dual-speed blower fan combine to provide cabinet air temperature as low as 0°F. The control closely monitors both the air and product temperatures to assure rapid chilling without freezing. The operator is notified upon completion of each chill cycle, and the unit automatically begins to maintain proper refrigerated storage temperatures. All chill cycle data is then stored in memory and can either be printed or downloaded to a PC on demand.

### Interior

Standard interior arrangements consist of 5 pairs of chrome wire tray slides, each of which can accommodate one (1) 12" x 20" steam table or 18" x 26" sheet pan.

### Warranties

The standard warranty is a one year parts and labor warranty on all components and the cabinet, and an additional four year parts only warranty on the compressor. Additional warranties are available at extra cost.

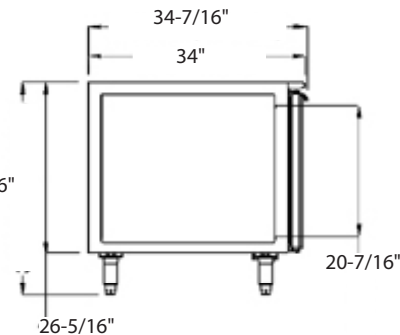
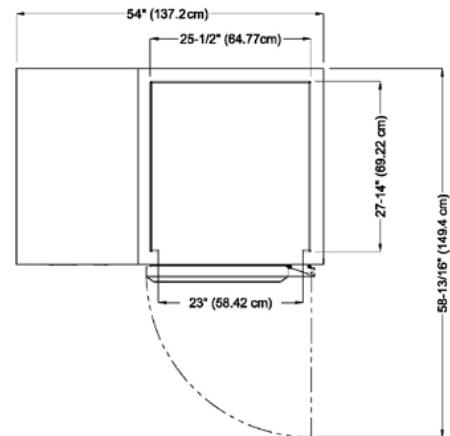
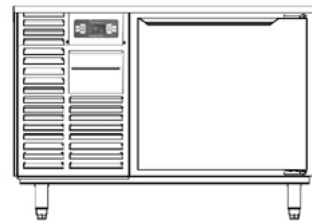

TRAUlsen  
4401 BLUE MOUND RD.  
PHONE 1 (800) 825-8220  
Website: www.traulsen.com

FT. WORTH, TX 76106  
FAX-MKTG. 1 (817) 624-4302

