



Your Solutions Partner

# Specifications

F.O.B Sedalia, Missouri 65301



1353

### OPTIONS:

- Enclosed base - 6" high
- Cord and plug - 8'
- Casters - 5" polyurethane, 2 swivel w/brakes 2 rigid
- Push bar
- Bumpers - stainless steel
- Door Panels - laminated plastic
- Additional pair 3" angle slides
- Door locks
- 440-480V Circuit
- Celsius thermometer in lieu of Fahrenheit
- 208V/1Ph; 208V/3Ph; 240V/1 PH; 240/3PH

### AGENCY LISTING:



**DUKE MANUFACTURING CO.**  
2305 N. Broadway  
St. Louis, MO 63102

**800.735.3853 Toll Free**  
**314.231.5074 Fax**  
**www.dukemfg.com**

SS-DM-00186-THM-13

### Approval Stamp(s):

### PRODUCT INFORMATION:

PROJECT: \_\_\_\_\_

ITEM: \_\_\_\_\_

QUANTITY: \_\_\_\_\_

MODEL:

### Thermotainer Food Holding Cabinets - "C" Series 9"H x 29"W x 23-1/2" D Compartments

- 1353** Reach-In 1 thermostat controls all 3 compartments, w/legs
- 1353P** Pass-Thru 1 thermostat controls all 3 compartments, w/legs

### BODY:

- Heavy gauge stainless steel, all panels except bottom
- Shell welded to interior
- Die-stamped compartment openings

### DOORS:

- Stainless steel, die-stamped, embossed front
- Ribbed Interior
- Reinforced for mounting hardware
- Insulated with fiberglass
- Spring hinges die-stamped, with built-in-stop externally adjustable, completely concealed

### COMPARTMENT:

- Heavy gauge stainless steel
- Rounded corners
- Stainless steel studs for angle slides at 3 levels
- (4) removable, adjustable, stainless steel, 3" angled slide pairs
- Removable liner for inspection and maintenance

### ELECTRICAL CONTROLS:

- Recessed thermostat w/built-in On-Off switch
- Heat range 100° - 300° and dial thermometer
- Pilot lights
- Recessed connection box
- Removable access panel

### DAMPERS:

- 2-position sliding type
- Controlled by push buttons
- Compartments individually controlled

### INSULATION:

- Body fully insulated with 1-1/2" fiberglass

### HEATING ELEMENTS:

- Sheath type strip heaters, 120 Volt, 1 Phase
- Removable compartment for ease of access to heating elements.

### LEGS:

- Stainless steel die-stamped adjustable - 6" high

### SHORT FORM SPECIFICATIONS:

**Duke Thermotainers Food Holding Cabinets.** Models 1353/1353P constructed with three (3) compartment. Compartment 9"H x 29" W x 23-1/2" D. Each compartment to have four (4) pairs of removable stainless steel slides. One thermostat controls all compartments. 100° - 300° heat range and dial thermometer with 6" high stainless steel legs. Built-in installation - allow 1/4" tolerance greater than body with.



**THERMOTAINER FOOD HOLDING CABINETS - "C" SERIES  
9"H x 29"W x 23-1/2"D COMPARTMENTS**

- **1353** Reach-In 1 thermostat controls all 3 compartments, w/ legs
- **1353P** Pass-Thru 1 thermostat controls all 3 compartments, w/legs

LEGEND	
▲	- ELECTRICAL CONNECTION

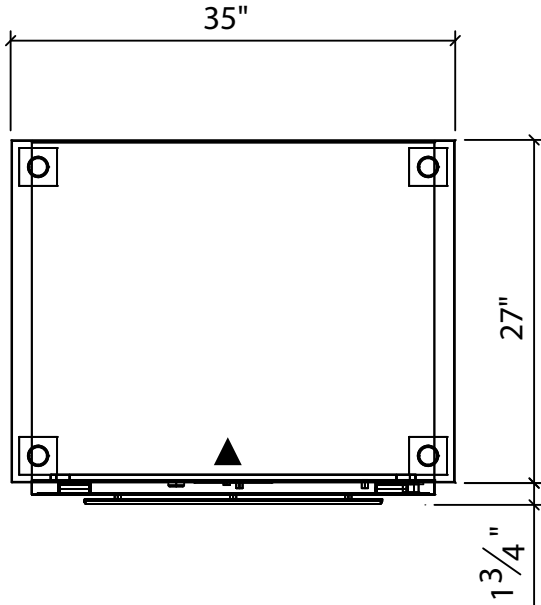

1353

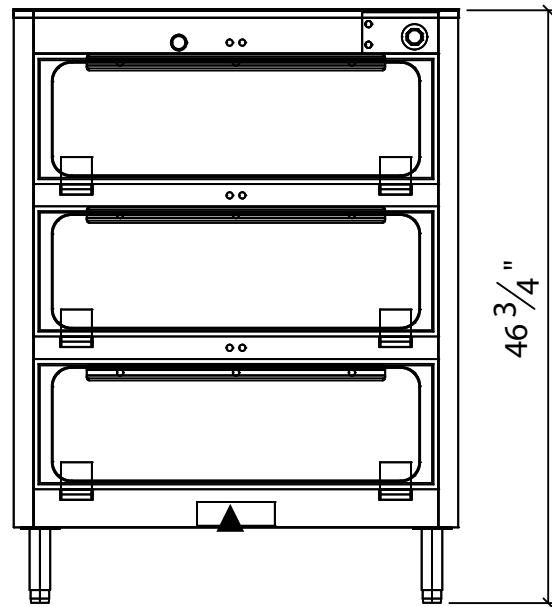

**DIMENSIONS:**

Freight Class: 100

Model	Width		Depth		Height		Comp. Depth		Cube ft. crated	Weight	
	in	cm	in	cm	in	cm	in	cm		lbs	kg
1353	35	88.9	28-3/4	73.0	46-3/4	118.8	23-1/2	59.7	42.5	500	227.3
1353P	35	88.9	30-1/2	77.5	46-3/4	118.8	25-1/2	64.8	44.8	550	250.

**ELECTRICAL SPECIFICATIONS:** (Consult factory for 3-phase electrical requirements and other options.) 120V, 1Ph

Model	Connected Load
1353	2000 watts
1353P	2000 watts

	1353/1353P
<b>Capacity w/standard slides</b>	(18) 12" x 20" x 2" pans or (12) 12" x 20" x 4" pans or (6) 12" x 20" x 8" pans

1353 Reach In - hinged doors on front only

1353P Pass Thru - hinged doors on front & back for pass-thru service



**DUKE MANUFACTURING CO.**

2305 N. Broadway  
St. Louis, MO 63102

800.735.3853 Toll Free  
314.231.1130 In Missouri  
314.231.5074 Fax  
www.dukemfg.com

Specification subject to change