



Your Solutions Partner

Specifications

F.O.B Sedalia, Missouri 65301

1601

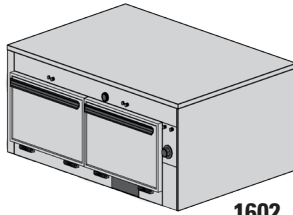
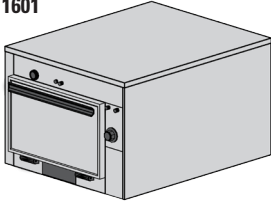

1602

OPTIONS:

- Enclosed base - 6" high
- Cord and plug - 8'
- Casters - 5" polyurethane, 2 swivel w/brakes 2 rigid
- Push bar
- Bumpers - stainless steel
- Door Panels - laminated plastic
- Additional pair 3" angle slides
- Door locks
- Legs
- 440-480V Circuit
- Celsius thermometer in lieu of Fahrenheit
- 208V/1Ph; 208V/3Ph; 240V/1 PH; 240/3PH

AGENCY LISTING:



DUKE MANUFACTURING CO.
 2305 N. Broadway
 St. Louis, MO 63102

800.735.3853 Toll Free
314.231.5074 Fax
www.dukemfg.com

SS-DM-00194-THM-21

Approval Stamp(s):

PRODUCT INFORMATION:

PROJECT: _____

ITEM: _____

QUANTITY: _____

MODEL:

Thermotainer Food Holding Cabinets - "A" Series 9"H x 14"W x 23-1/2" D Compartments

- 1601** Reach-In 1 thermostat for 1 compartment , w/o legs
- 1601P** Pass-Thru 1 thermostat for 1 compartment, w/o legs
- 1602** Reach-In 1 thermostat for 2 compartments , w/o legs
- 1602P** Pass-Thru 1 thermostat for 2 compartments, w/o legs

BODY:

- Heavy gauge stainless steel, all panels except bottom
- Shell welded to interior
- Die-stamped compartment openings

DOORS:

- Stainless steel, die-stamped, embossed front
- Ribbed Interior
- Reinforced for mounting hardware
- Insulated with fiberglass
- Spring hinges die-stamped, with built-in-stop externally adjustable, completely concealed

COMPARTMENT:

- Heavy gauge stainless steel
- Rounded corners
- Stainless steel studs for angle slides at 3 levels
- (2) removable, adjustable, stainless steel, 3" angled slide pairs
- Removable liner for inspection and maintenance

ELECTRICAL CONTROLS:

- Recessed thermostat w/built-in On-Off switch
- Heat range 100° - 300°
- Pilot lights
- Recessed connection box
- Thermostat, pilot lights set in removable access panel

DAMPERS:

- 2-position sliding type
- Controlled by push buttons
- Compartments individually controlled

INSULATION:

- Body fully insulated with 1-1/2" fiberglass, doors with fiberglass.

HEATING ELEMENTS:

- Sheath type strip heaters, 120 Volt, 1 Phase
- Removable compartment for ease of access to heating elements.

SHORT FORM SPECIFICATIONS:

Duke Thermotainers Food Holding Cabinets. Models **1601/1601P** constructed with one (1) compartment. Models **1602/1602P** to have two (2) compartments. Compartments 9"H x 14"W x 23-1/2"D. Each compartment to have two (2) pairs of removable stainless steel slides. One thermostat for all compartments. 100° - 300°F heat range with dial thermometer. Built-in installation - allow 1/4" tolerance greater than body width.



THERMOTAINER FOOD HOLDING CABINETS - "A" SERIES
9"H x 14"W x 23-1/2"D COMPARTMENTS

- 1601** Reach-In 1 thermostat for 1 compartments, w/o legs
- 1601P** Pass-Thru 1 thermostat for 1 compartments, w/o legs
- 1602** Reach-In 1 thermostat for 2 compartments, w/o legs
- 1602P** Pass-Thru 1 thermostat for 2 compartments, w/o legs

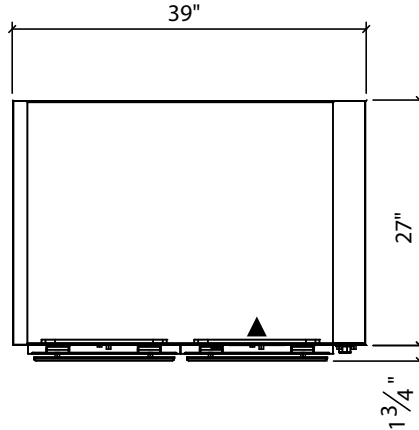
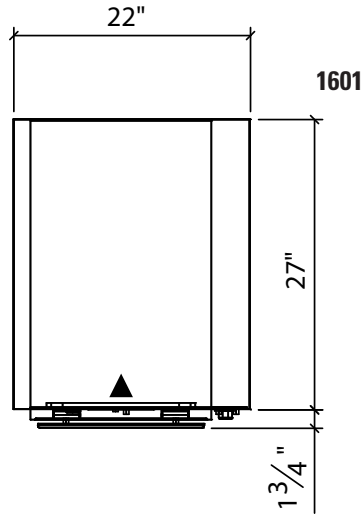

LEGEND	
	- ELECTRICAL CONNECTION

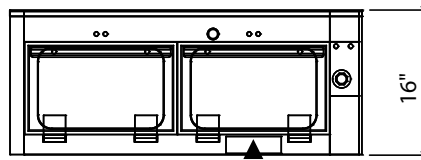
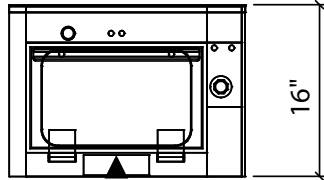

DIMENSIONS:

Freight Class: 100

Model	Width		Depth		Height		Comp. Depth		Cube ft. crated	Weight	
	in	cm	in	cm	in	cm	in	cm		lbs	kg
1601	22	55.9	28-3/4	73.0	16	40.6	23-1/2	59.7	12.7	130	59.1
1601P	22	55.9	30-1/2	77.5	16	40.6	25-1/2	64.8	13.2	130	59.1
1602	39	99.1	28-3/4	73.0	16	40.6	23-1/2	59.7	20.0	225	102.3
1602P	39	99.1	30-1/2	77.5	16	40.6	25-1/2	64.8	21.1	225	102.6

ELECTRICAL SPECIFICATIONS: (Consult factory for 3-phase electrical requirements and other options.)

Model	Connected Load
1601	750 watts
1601P	750 watts
1602	1125 watts
1602P	1125 watts

	1601/1601P	1602/1602P
Capacity w/standard slides	(3) 12" x 20" x 2" pans or (2) 12" x 20" x 4" pans or (1) 12" x 20" x 8" pans	(6) 12" x 20" x 2" pans or (4) 12" x 20" x 4" pans or (2) 12" x 20" x 8" pans

- 1601** Reach In - hinged doors on front only
- 1601P** Pass Thru - hinged doors on front & back for pass-thru service
- 1602** Reach In - hinged doors on front only
- 1602P** Pass Thru - hinged doors on front & back for pass-thru service



DUKE MANUFACTURING CO.

2305 N. Broadway
 St. Louis, MO 63102

800.735.3853 Toll Free
 314.231.1130 In Missouri
 314.231.5074 Fax
www.dukemfg.com

Specification subject to change