

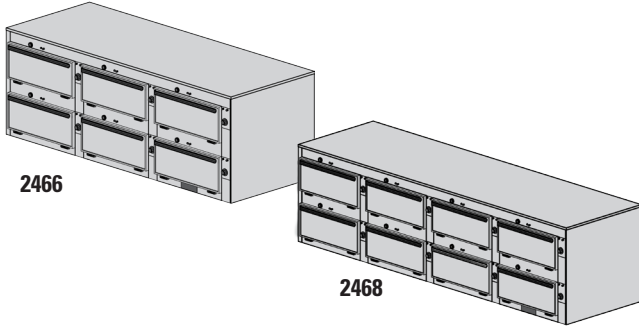

Your Solutions Partner

Specifications

F.O.B Sedalia, Missouri 65301



OPTIONS:

- Enclosed base - 6" high
- Cord and plug - 8'
- Casters - 5" polyurethane, 2 swivel w/brakes 2 rigid
- Push bar
- Bumpers - stainless steel
- Door Panels - laminated plastic
- Additional pair 5" angle slides
- Door locks
- Legs
- 440-480V Circuit
- Celsius thermometer in lieu of Fahrenheit
- 208V/1Ph; 208V/3Ph; 240V/1 PH; 240/3PH

AGENCY LISTING:



DUKE MANUFACTURING CO.
2305 N. Broadway
St. Louis, MO 63102

800.735.3853 Toll Free
314.231.5074 Fax
www.dukemfg.com

SS-DM-00209-THM-36

Approval Stamp(s):

PRODUCT INFORMATION:

PROJECT: _____
ITEM: _____
QUANTITY: _____

MODEL:

Thermotainer Food Holding Cabinets - "B" Series
9"H x 22"W x 28-1/2" D Compartments

- 2466** Reach-In 1 thermostat per compartment , w/o legs
- 2466P** Pass-Thru 1 thermostat per compartment , w/o legs
- 2468** Reach-In 1 thermostat per compartment , w/o legs
- 2468P** Pass-Thru 1 thermostat per compartment , w/o legs

BODY:

- Heavy gauge stainless steel, all panels except bottom
- Shell welded to interior
- Die-stamped compartment openings

DOORS:

- Stainless steel, die-stamped, embossed front
- Ribbed Interior
- Reinforced for mounting hardware
- Insulated with fiberglass
- Spring hinges die-stamped, with built-in-stop externally adjustable, completely concealed

COMPARTMENT:

- Heavy gauge stainless steel
- Rounded corners
- Stainless steel studs for angle slides at 3 levels
- (2) removable, adjustable, stainless steel, 5" angled slide pairs
- Removable liner for inspection and maintenance

ELECTRICAL CONTROLS:

- Recessed thermostat w/built-in On-Off switch
- Heat range 100° - 300° and dial thermometer
- Pilot lights
- Recessed connection box
- Removable access panel

DAMPERS:

- 2-position sliding type
- Controlled by push buttons
- Compartments individually controlled

INSULATION:

- Body fully insulated with 1-1/2" fiberglass

HEATING ELEMENTS:

- Sheath type strip heaters, 120 Volt, 1 Phase
- Removable compartment for ease of access to heating elements.

SHORT FORM SPECIFICATIONS:

Duke Thermotainers Food Holding Cabinets. Models 2466/2466P constructed with six (6) compartments. Models 2468/2468P to have eight (8) compartments. Compartments 9"H x 22"W x 28-1/2"D. Each compartment to have two (2) pairs of removable stainless steel slides. One thermostat per compartment. 100° - 300°F heat range with dial thermometer. Built-in installation - allow 1/4" tolerance greater than body width.



**THERMOTAINER FOOD HOLDING CABINETS - "B" SERIES
9"H x 22"W x 28-1/2"D COMPARTMENTS**

- 2466** Reach-In 1 thermostat per compartment, w/o legs
- 2466P** Pass-Thru 1 thermostat per compartment, w/o legs
- 2468** Reach-In 1 thermostat per compartment, w/o legs
- 2468P** Pass-Thru 1 thermostat per compartment, w/o legs

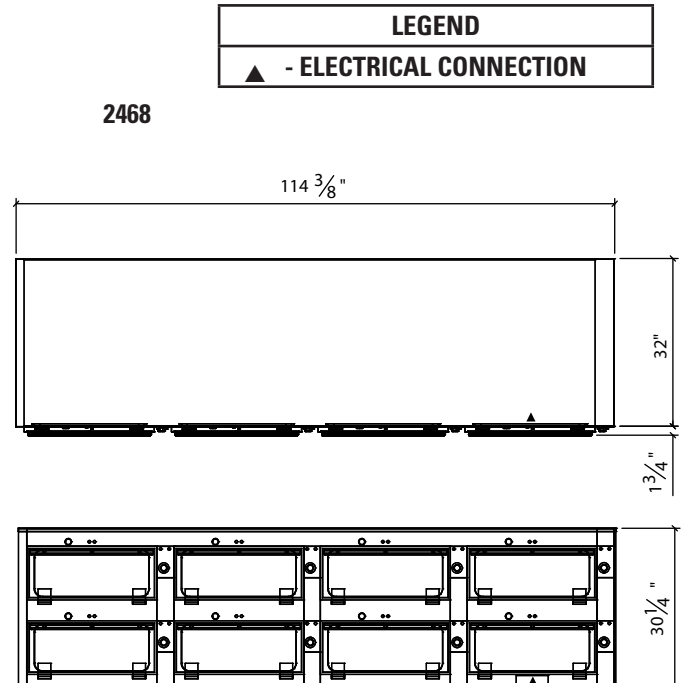
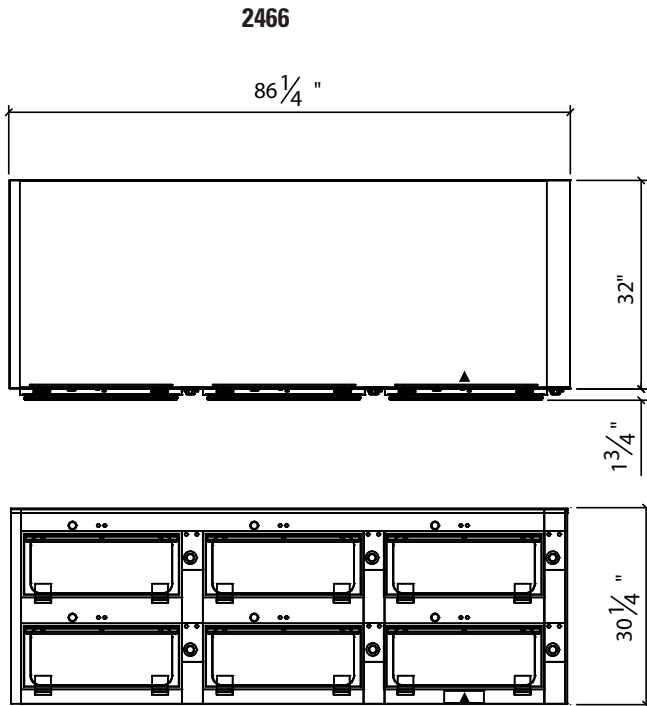

DIMENSIONS:

Freight Class: 100

Model	Width		Depth		Height		Comp. Depth		Cube ft. crated	Weight	
	in	cm	in	cm	in	cm	in	cm		lbs	kg
2466	86-1/4	219.1	33-3/4	85.7	30-1/4	76.8	28-1/2	72.4	77.1	950	431.8
2466P	86-1/4	219.1	35-1/2	90.2	30-1/4	76.8	30-1/2	77.5	80.7	950	431.8
2468	114-3/8	290.6	33-3/4	85.7	30-1/4	76.8	28-1/2	72.4	100.6	1100	500.0
2468P	114-3/8	290.6	35-1/2	90.2	30-1/4	76.8	30-1/2	77.5	105.3	1100	500.0

ELECTRICAL SPECIFICATIONS: (Consult factory for 3-phase electrical requirements and other options.) 120V, 1Ph

Model	Connected Load
2466	4500 watts
2466P	4500 watts
2468	6000 watts
2468P	6000 watts

	2466/2466P	2468/2468P
Capacity w/standard slides	(36) 12" x 20" x 2" pans or (24) 12" x 20" x 4" pans or (12) 12" x 20" x 8" pans (18) 18" x 26" bake sheets	(48) 12" x 20" x 2" pans or (32) 12" x 20" x 4" pans or (16) 12" x 20" x 8" pans (24) 18" x 26" bake sheets

- 2466** Reach In - hinged doors on front only
- 2466P** Pass Thru - hinged doors on front & back for pass-thru service
- 2468** Reach In - hinged doors on front only
- 2468P** Pass Thru - hinged doors on front & back for pass-thru service



DUKE MANUFACTURING CO.

2305 N. Broadway
St. Louis, MO 63102

800.735.3853 Toll Free
314.231.1130 In Missouri
314.231.5074 Fax
www.dukemfg.com

Specification subject to change