

# CONTINUOUS FLOW FROZEN CUSTARD MACHINE

CC202



- Quick-Freeze Technology minimizes size of ice crystals to ensure smoother, creamier product.
- Hold cycle keeps barrels at a safe temperature during off-cycle periods.
- Easy to clean design ensures sanitary operation and ensures product is always fresh.
- Refrigerated hopper with independent temperature control maintains safe storage temperatures in any environment.
- Delrin, food grade plastic blades provide quiet operation and superior durability.
- Standard dipper well keeps scoops and spades clean.
- Highest production model (per barrel) without sacrificing the quality of product.
- Continuous feed system provides high-speed production with low overrun.
- Service panel provides easy access to temperature controls.
- Optional dual temperature control switch allows for production of various types of frozen treats, such as Italian ice, sorbet, and frozen custard.
- Optional hopper rinse faucet.



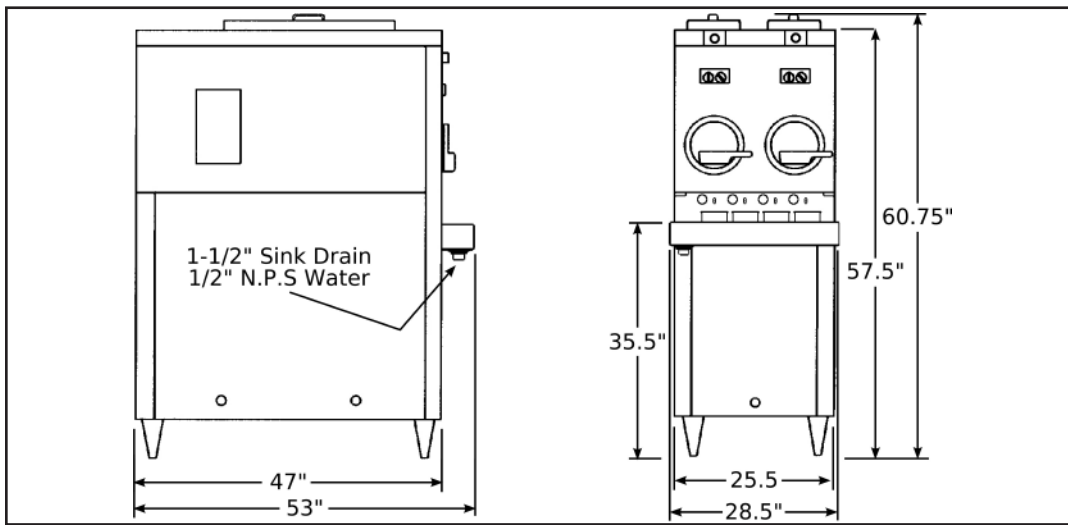

	CC202 Air Cooled		CC202 Water Cooled	
Dimensions	Freezer	with crate	Freezer	with crate
width	25-1/2" (64,8 cm)	42-1/2" (108,0 cm)	25-1/2" (64,8 cm)	42-1/2" (108,0 cm)
height	61-1/2" (156,2 cm)	67" (170,2 cm)	61-1/2" (156,2 cm)	67" (170,2 cm)
depth	47" (119,4 cm)	60" (152,4 cm)	47" (119,4 cm)	60" (152,4 cm)
<b>Weight</b>	905 lbs (410,5 kg)	1205 lbs (546,5 kg)	1206 lbs (547,0 kg)	1506 lbs (683,1 kg)
<b>Electrical</b>	1 Phase, 208-230 VAC, 60Hz		3 Phase, 208-230 VAC, 60Hz	
circuit ampacity	24A minimum	17A minimum	25A minimum	21A minimum
overcurrent protection device	30A maximum	25A maximum	37A maximum	31A maximum
<b>Hopper Condenser</b>	1 Phase, 115 VAC, 60Hz NEMA5-15P power cord provided			
<b>Drive Motor</b>	Two - 3 hp			
<b>Cooling</b>	Air cooled units require a remote condenser and approximately 24 lbs of R-404A (depending on line set length) per barrel.		Water cooled units are self contained and require a Standard Hose Adapter water fitting and a 5/8" OD drain fitting for each barrel. They are charged with R-404A.	
<b>Hopper Volume</b>	Two - 7.5 gallon (28,40 liters)			
<b>Warranty</b>	Two-year warranty on compressor, evaporator assembly, drive motor and auger. One-year warranty on remaining parts and labor.			

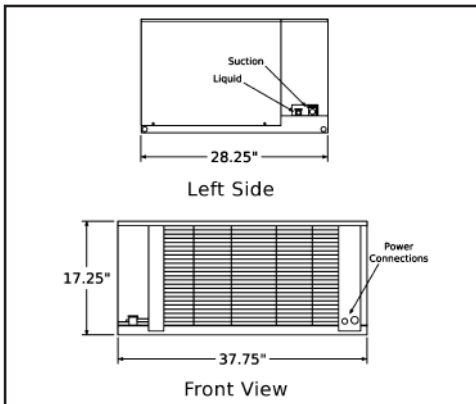

	Remote Condenser
Dimensions	Condenser
width	37-3/4" (95,9 cm)
height	17-1/4" (43,7 cm)
depth	28-1/4" (71,7 cm)
<b>Weight</b>	222 lbs (100,7 kg)
<b>Electrical</b>	<b>3 Phase, 208-230 VAC, 60Hz</b>
<b>Refrigerated Line Sizes</b>	Liquid Line - 3/8" Suction Line - 7/8"

Continuous research leads to ongoing product improvements; therefore, these specifications are subject to change without notice.

Distributed by:



**FOODSERVICE EQUIPMENT**  
 502 Highway 67 • Kiel, WI 53042-1600  
 920-894-2293 • 800-558-5807  
 Fax: 920-894-7029  
 E-mail: [foodservice@stoelting.com](mailto:foodservice@stoelting.com)  
[www.stoeltingfoodservice.com](http://www.stoeltingfoodservice.com)

ISO 9001:2000 Registered

Certified, Listed and/or Recognized by:

