

Item No. \_\_\_\_\_

**Model Number:** 2004SL

**Description**

**ASTRO POP WARMER**



These two high capacity three shelf warmers are ideal for busy theatres or other locations, which use cafeteria service.

High capacity forced hot air Corn Freshener System works fast. The large 36W x 28D x 44"H cabinet with illuminated sign features 1830 watts of corn freshening.

The SL version features self-closing sliding doors on the customer side for self serve. A perfect compliment to the Pop-O-Gold in high traffic locations. Shipping weight - 150 lbs. Be sure to specify #2004 or #2004SL. (Deluxe Neon version available on special order. Ask for quotation.)



### **Gold Medal Products Co.**

10700 Medallion Drive  
Cincinnati, Ohio 45241-4807  
E-Mail [goldme19@eos.net](mailto:goldme19@eos.net)  
Web Site [gmpopcorn.com](http://gmpopcorn.com)

Phone: (513) 769-7676  
(800) 543-0862  
Fax: (513) 769-8500  
Toll Free Fax (800) 542-1496

Model Number: 2004SL

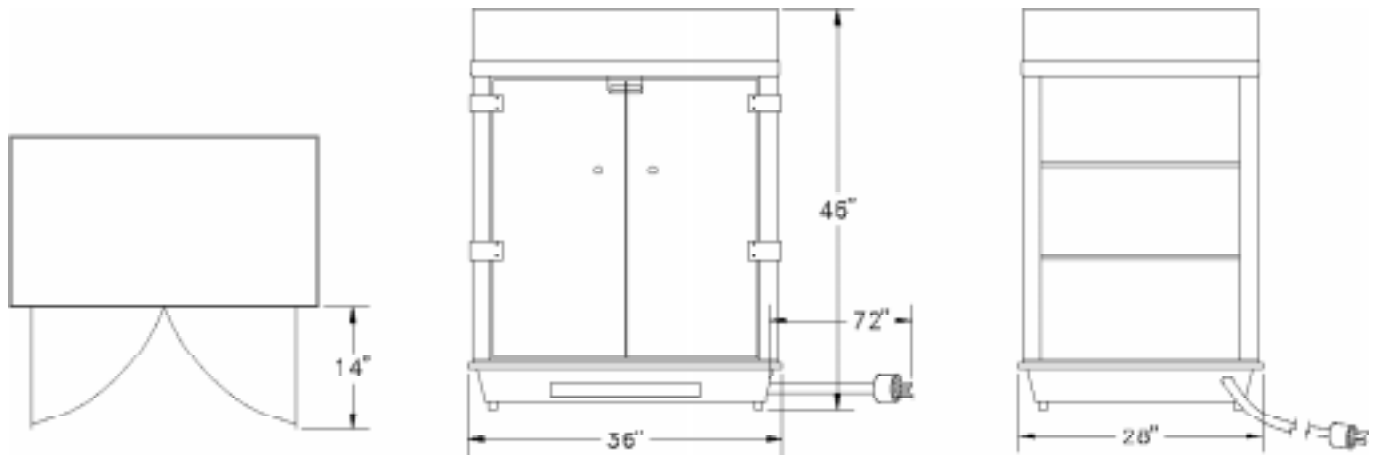

Width: 36.00  
Length: 28.00  
Height: 40.00  
Weight: 145

Pkg Width: 39.00  
Pkg Length: 31.00  
Pkg Height: 52.00  
Pkg Weight: 151.00  
CU/FT: 36.38

Voltage: 120  
AMPS: 16  
Wattage: 1830

Hertz: 60  
Receptacle: 5-20R  
Plug Type: 5-20P

#### Model Variations

### Gold Medal Products Co.

10700 Medallion Drive  
Cincinnati, Ohio 45241-4807  
E-Mail [goldme19@eos.net](mailto:goldme19@eos.net)  
Web Site [gmpopcorn.com](http://gmpopcorn.com)

Phone: (513) 769-7676  
(800) 543-0862  
Fax: (513) 769-8500  
Toll Free Fax (800) 542-1496