



Profit from the Eagle Advantage®

Specification Sheet

Short Form Specifications

Eagle Hot Food Tables, Spec-Master® series, model _____ enclosed base design. Top and body to be heavy gauge type 430 stainless steel (Open Front or Sliding Doors). Beaded top openings to be 12½" x 20½". Heating compartments to be 8" deep, galvanized, and insulated on all four sides and bottom with 1" fiberglass or equal. Recessed control panel with individual thermostatic controls. Each compartment fitted with 750-watt tubular heating element above the insulated bottom. Wiring terminates at junction box for final field wiring. Complete unit wired to master toggle switch with indicator light. Furnished with polycarbonate cutting board. 7½" high legs are 1½" O.D. stainless steel tubing with adjustable non-marking plastic bullet feet.



#HT3OB-120 unit with open front

Options / Accessories

- Thermoplastic cutting boards
- 1000-watt heater*
- Spillage pans
- Rolltop cover
- Food pans/insets
- Tray slides/shelves
- Top adapters
- Hardwood cutting board
- Decorative laminates
- Spec-Master® marine edge

* For 208V and 240V models only. To order, add suffix "-1". Example: HT30B-120-1
* See Catalog Sheet #EG30.18 for more information on Flex-Master® overselves

EAGLE GROUP

100 Industrial Boulevard, Clayton, DE 19938-8903 USA
Phone: 302-653-3000 • Fax: 302-653-2065
www.eaglegrp.com

Foodservice Division: Phone 800-441-8440
MHC/Retail Display Divisions: Phone 800-637-5100

For custom configuration or fabrication needs, contact our SpecFAB® Division.
Phone: 302-653-3000 • Fax: 302-653-3091 • e-mail: specfab@eaglegrp.com

Spec sheets available for viewing, printing or downloading from our online literature library at www.eaglegrp.com

Eagle Foodservice Equipment, Eagle MHC, SpecFAB®, and Retail Display are divisions of Eagle Group. ©2010 by the Eagle Group

KaTom Restaurant Supply, Inc.

Item No.: _____
 Project No.: _____
 S.I.S. No.: _____

Spec-Master® Electric Hot Food Tables—Enclosed Base, Stationary

MODELS:

- HT2CB-120
- HT2CB-240*
- HT2OB-120
- HT2OB-240*
- HT3CB-120
- HT3CB-240*
- HT3OB-120
- HT3OB-240*
- HT4CB-120
- HT4CB-240*
- HT4OB-120
- HT4OB-240*
- HT5CB-240*
- HT5OB-240*
- HT6CB-240*
- HT6OB-240*

* These units are available in three-phase. To order, add suffix "-3". Ex: HT3CB-240-3

Construction

- Table body constructed of 20 gauge type 430 series stainless steel, top constructed of 22 gauge type 430 series stainless steel.
- Top has die-stamped beaded openings measuring 12½" x 20½" (307 x 510mm).
- A poly cutting board, 8" wide x ½" (203 x 13mm) thick, is mounted on stainless steel brackets located on control side of unit.
- Legs are 1½" (41mm) O.D. stainless steel tubing fitted with adjustable non-marking plastic feet.

Controls

- Individual thermostatic controls offer a wide range of temperature settings.
- Indicator light remain on continuously while control is on.

Heat Compartments

- Each heat compartment is 8" (203mm) deep and lined with 22 gauge galvanized steel.
- Each compartment is insulated on all four sides and bottom with 1" (25mm) thick fiberglass or equal.

Electrical

- Each compartment is fitted with a 750-watt tubular element above the insulated bottom.
- ALL UNITS ARE DESIGNED FOR FIELD WIRING. All wiring to terminate in a junction box located within cabinet for field wiring to power source. Complete unit is wired to a master toggle switch with indicator light.
- 120-volt units are single phase. 240-volt units available in single- and three-phase.

Sliding Doors (when indicated)

- 22 gauge stainless steel construction complete with recessed stainless steel handle.
- Doors sit within an exclusive rollerless track assembly, providing easier cleaning and lower maintenance.

Certifications / Approvals



New York MEA 376-84-E





Item No.: _____
 Project No.: _____
 S.I.S. No.: _____

Electric Hot Food Tables—Enclosed Base, Stationary

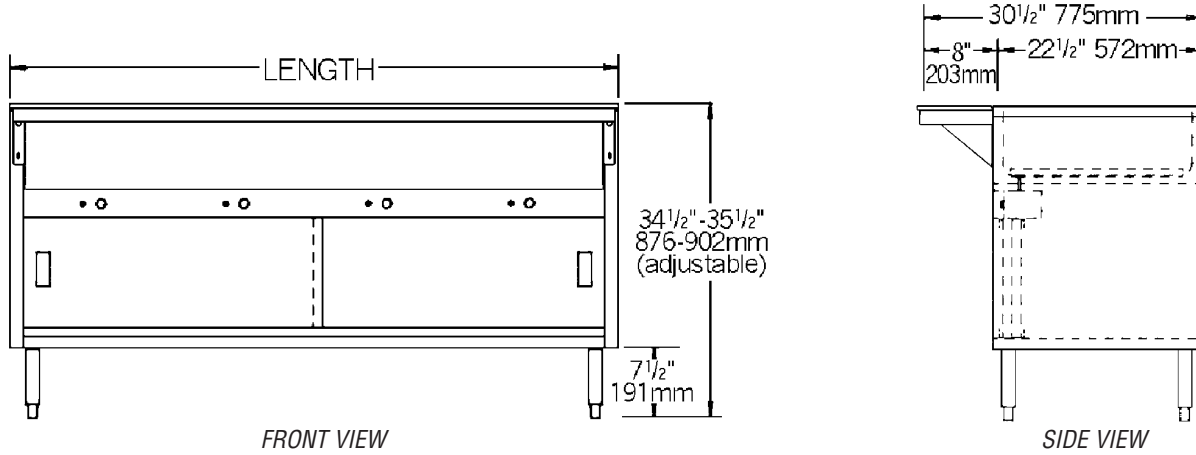

(note: unit with sliding doors shown)

# of top openings	length in. mm		weight lbs. kg		volts watts		WITH OPEN FRONT				WITH SLIDING DOORS			
							SINGLE-PHASE		THREE-PHASE		SINGLE-PHASE		THREE-PHASE	
							amps	model #	amps	model #	amps	model #	amps	model #
2	33"	838	200	90.7	120V	1500W	12.5A	HT2OB-120	n/a	12.5A	HT2CB-120	n/a		
2	33"	838	200	90.7	240V	1500W	6.3A	HT2OB-240	5.4A	HT2OB-240-3	6.3A	HT2CB-240	5.4A	HT2CB-240-3
3	48"	1219	240	108.9	120V	2250W	18.8A	HT3OB-120	n/a	18.8A	HT3CB-120	n/a		
3	48"	1219	240	108.9	240V	2250W	9.4A	HT3OB-240	5.4A	HT3OB-240-3	9.4A	HT3CB-240	5.4A	HT3CB-240-3
4	63 1/2"	1613	280	127.0	120V	3000W	25.0A	HT4OB-120	n/a	25.0A	HT4CB-120	n/a		
4	63 1/2"	1613	280	127.0	240V	3000W	12.5A	HT4OB-240	8.3A	HT4OB-240-3	12.5A	HT4CB-240	8.3A	HT4CB-240-3
5	79"	2007	320	145.2	240V	3750W	15.7A	HT5OB-240	10.8A	HT5OB-240-3	15.7A	HT5CB-240	10.8A	HT5CB-240-3
6	94 1/2"	2400	363	164.7	240V	4500W	18.8A	HT6OB-240	10.8A	HT6OB-240-3	18.8A	HT6CB-240	10.8A	HT6CB-240-3

Note: 240-volt units also available in 208 volt. To order, replace suffix "-240" with suffix "-208". Example: HT3OB-208

FLEX-MASTER® Overshelf Kits

Both kits include two 16/304 overshelves and four 30" (762mm) posts. Add suffix specified to order kit (example: DHT2-120-FMU), or design your own using standard components from EG30.18.

description	add suffix
10" (254mm) overshelves	-FM
15" (381mm) overshelves, plus one ladle rack	-FMU

EAGLE GROUP

100 Industrial Boulevard, Clayton, DE 19938-8903 USA
 Phone: 302-653-3000 • Fax: 302-653-2065
 www.eaglegrp.com

Foodservice Division: Phone 800-441-8440
 MHC/Retail Display Divisions: Phone 800-637-5100

Printed in U.S.A.
 ©2010 by Eagle Group
 Rev. 05/10

Spec sheets available for viewing, printing or downloading from our online literature library at www.eaglegrp.com

Although every attempt has been made to ensure the accuracy of the information provided, we cannot be held responsible for typographical or printing errors. Information and specifications are subject to change without notice. Please confirm at time of order.