



Profit from the Eagle Advantage®

Specification Sheet

Short Form Specifications

Eagle Panco® Full Size Stationary Can Rack, model FCR-10-9A. All-welded aluminum construction, crossbraced front-to-back and side-to-side. Aluminum angle rack slides secured to frame at a slight angle to allow for gravity feed. Capacity: 162 #10 cans or 216 #5 cans.

Eagle Panco® Full Size Mobile Can Rack, model OCR-10-9A. All-welded aluminum construction, crossbraced front-to-back and side-to-side. Aluminum angle rack slides secured to frame at a slight angle to allow for gravity feed. Furnished with 4"-diameter casters. Capacity: 162 #10 cans or 216 #5 cans.



model #OCR-10-9A
mobile can rack

Options / Accessories

- Casters with locking brakes (for mobile unit only)*
- Perimeter bumpers
- Vertical corner bumpers

* Stationary unit cannot accept caster option.

EAGLE GROUP

100 Industrial Boulevard, Clayton, DE 19938-8903 USA
Phone: 302-653-3000 • Fax: 302-653-2065
www.eaglegrp.com

Foodservice Division: Phone 800-441-8440

MHC/Retail Display Divisions: Phone 800-637-5100

For custom configuration or fabrication needs, contact our **SpecFAB®** Division.

Phone: 302-653-3000 • Fax: 302-653-3091 • e-mail: specfab@eaglegrp.com

Item No.:	_____
Project No.:	_____
S.I.S. No.:	_____

Panco® Can Racks —Full Size

MODELS:

- FCR-10-9A
- OCR-10-9A

Design and Construction Features

- All-welded construction. Both racks are constructed of high-strength aluminum sections.
- Frame and supports: square aluminum tubing. Crossbraced front-to-back and side-to-side on top and bottom of unit.
- Rack slides made from aluminum angles, secured to frame at a slight angle for gravity feed.
- Casters on mobile unit: 4" (127mm)-diameter non-marking swivel plate casters with polymer tread, two with brake.
- Stationary unit comes with adjustable feet.
- Provides automatic stock rotation when loaded from rear.
- Shipped assembled.

Certifications / Approvals



EG60.15A Rev. 08/08

Spec sheets available for viewing, printing or downloading from our online literature library at www.eaglegrp.com

Eagle Foodservice Equipment, Eagle MHC, SpecFAB®, and Retail Display are divisions of Eagle Group. ©2008 by the Eagle Group

KaTom Restaurant Supply, Inc.



Item No.: _____
 Project No.: _____
 S.I.S. No.: _____

Panco® Can Racks—Full Size

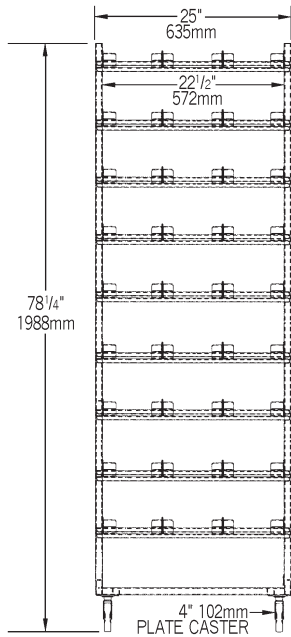

FRONT VIEW

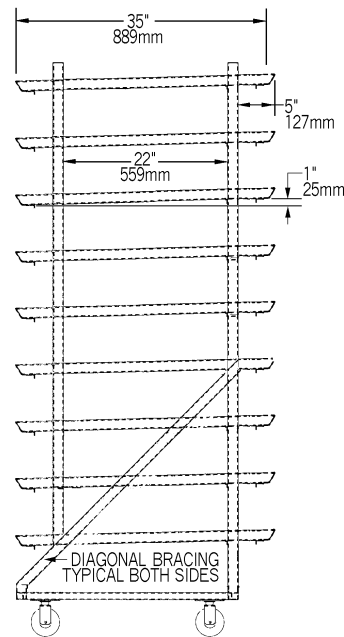

SIDE VIEW

(#OCR-10-9A shown)

model #	description	overall dimensions						sliding space		can capacity		# of tiers high	weight	
		in.	mm	in.	mm	in.	mm	in.	mm	#10	#5		lbs.	kg
FCR-10-9A	full size, stationary	25"	635	35"	889	71"	1803	7 1/2"	191	162	216	9	63	28.6
OCR-10-9A	full size, mobile	25"	635	35"	889	78 1/4"	1988	7 1/2"	191	162	216	9	63	28.6

EAGLE GROUP
 100 Industrial Boulevard, Clayton, DE 19938-8903 USA
 Phone: 302-653-3000 • Fax: 302-653-2065
 www.eaglegrp.com

Foodservice Division: Phone 800-441-8440
 MHC/Retail Display Divisions: Phone 800-637-5100

Printed in U.S.A.
 ©2008 by Eagle Group
 Rev. 08/08

Spec sheets available for viewing, printing or downloading from our online literature library at www.eaglegrp.com

Although every attempt has been made to ensure the accuracy of the information provided, we cannot be held responsible for typographical or printing errors. Information and specifications are subject to change without notice. Please confirm at time of order.