



**BLAST CHILLER / SHOCK FREEZER
(Self-Contained)
Model: AP10BCF100-2**

JOB _____

ITEM # _____

QTY. REQUIRED _____

AIA FILE # _____

SPEC # _____

SPECIFICATIONS

SCOPE: This specification covers the model AP10BCF100-2 HurriChill™ Blast Chiller/Shock Freezer. This compact unit has a self-contained, air-cooled refrigeration system and is complete with all required controls and accessories. Several options are also available.

GENERAL: The microprocessor control system provides a choice of operating cycles: soft chilling, hard chilling, shock freezing, holding, and sterilizing. A heated core temperature probe is provided for accurate control of temperature within the product. Cabinet interior has removable pan slides and a capacity of (10) 12" x 20" x 2-1/2" deep food pans.

PERFORMANCE: Blast chilling (soft or hard) lowers the food core temperature from 160°F to 38°F within 90 minutes. Shock freezing lowers the food core temperature from 160°F to 0°F within 4 hours. Chilling and freezing times will vary somewhat, depending on the food quantity, initial temperature, density, moisture content, specific heat, and type of container. The airflow has a high velocity, indirect pattern designed to cool all levels at identical rates. Time/temperature chilling and freezing rates meet or exceed all FDA and state regulations.

CONSTRUCTION: The chilling/freezing cabinet is constructed of polished type 304 stainless steel, with 2" of CFC-free, high density polyurethane insulation. The interior panels have a mirror finish and interior bottom corners are fully rounded. The door is equipped with a removable magnetic gasket. The door is hinged on operator's left. All motors are sealed ball bearing wash-down type. A 6' long three wire cord set with a NEMA L6-20P plug is provided.

REFRIGERATION SYSTEM: The self-contained refrigeration system includes a condensing unit using R-404A refrigerant. The evaporator temperature range is +25°F to -40°F. The compressor is a hermetic type with inherent overload protection.

MICROPROCESSOR CONTROL SYSTEM: The solid state electronic control panel is user friendly, easy to reach, and can be set for automatic or manual operation. The heated core probe continuously measures the product temperature during the chilling or freezing cycles. At the end of the freezing cycle the probe can be heated for ease of removal from the frozen product. Easy to read VFD display and buzzer alarm are standard features. All settings are programmable by the operator. The standard operating cycles include the following:

- Soft Chilling:** The air temperature is held in the range of 28°F to 35°F, ideal for delicate food items. The chilling cycle is completed when the food core temperature reaches 38°F to 40°F.
- Hard Chilling:** The air temperature is lowered to 0°F. When the food core temperature reaches 60°F, the air temperature rises to a range of 28°F to 35°F. The chilling cycle is completed when the food core temperature reaches 38°F to 40°F.
- Shock Freezing:** This cycle is designed to avoid damage to the food structure, keeping the food free of large ice crystals. The air temperature is lowered to and held at -25°F. The freezing cycle is completed when the food core temperature reaches 0°F.



- Thawing (Optional):** Air temperature is carefully monitored and alternates between gentle heat and refrigeration to safely thaw food product.
- Holding:** At the end of any cycle (soft chilling, hard chilling or shock freezing), the unit will automatically switch to a holding mode which will keep the food at 38°F (chilled) or at 0°F (frozen) until the **START/STOP** button is pressed to end the cycle. If the door is opened before pressing the **START/STOP** button, the holding mode will resume when the door is closed and continue until the **START/STOP** button is pressed.

ADDITIONAL FEATURES:

- Defrost:** An automatic defrost cycle is factory preset and will initiate after each 24 hours of operation. A manual defrost override can be selected at any time at the user's discretion.
- Recipe Names:** Up to 150 recipe names can be programmed by the user.

BLAST CHILLER / SHOCK FREEZER (Self-Contained)
Model: AP10BCF100-2



Details and Dimensions

BLAST CHILLER / SHOCK FREEZER (Self-Contained) Model: AP10BCF100-2

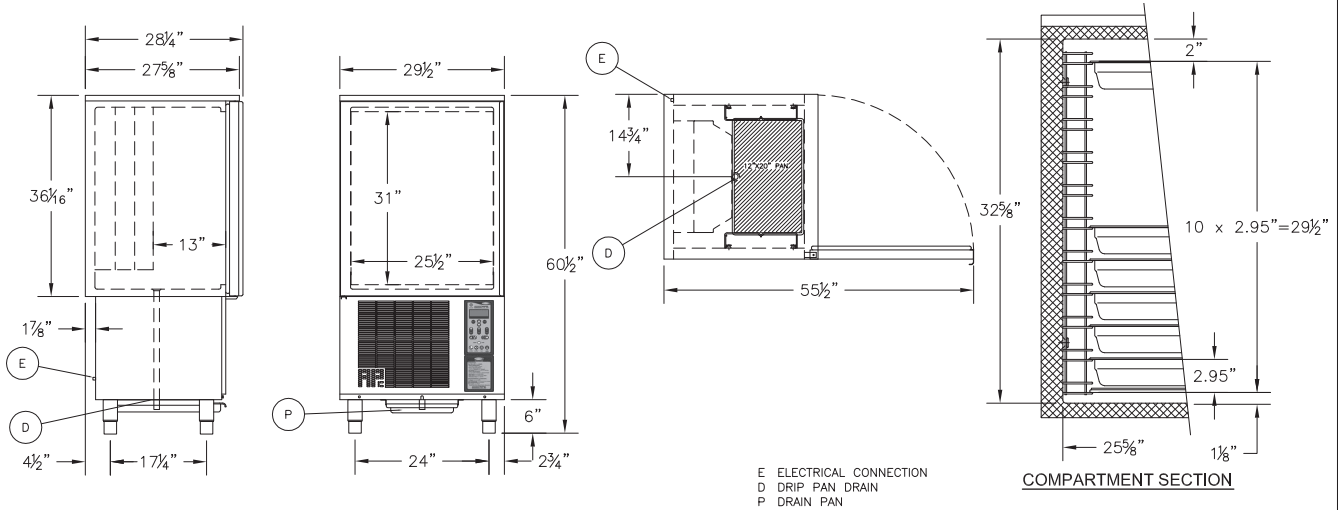

| DIMENSIONS | OUTSIDE | | | INSIDE | | | DEPTH WITH DOOR OPENED | SHIPPING WEIGHT [LBS] |
|-------------|---------|---------|---------|---------|-------|---------|------------------------|-----------------------|
| | WIDTH | DEPTH | HEIGHT | WIDTH | DEPTH | HEIGHT | | |
| ENGLISH | 29-1/2" | 28-1/4" | 60-1/2" | 25-5/8" | 13" | 32-5/8" | 55-1/2" | 510 |
| METRIC [MM] | 749 | 718 | 902 | 651 | 352 | 378 | 1410 | |

| MODEL | MAXIMUM LOAD PER CYCLE [LBS] | | ELECTRICAL TOTAL | | | | | COMPRESSOR HP |
|--------------|------------------------------|--------|------------------|-----|-----|-------|--------|---------------|
| | CHILL | FREEZE | VOLTS | PH. | HZ. | AMPS. | NEMA | |
| AP10BCF100-2 | 100 | 60 | 208 | 1 | 60 | 12 | L6-20P | 1.20 |

OPTIONS:

- Sterilizing:** The ultraviolet system sterilizes all metal surfaces within the cabinet in a preset time of 30 minutes. The mirror finish of the cabinet interior is specifically designed to optimize the performance of the UV cycle. The system is not intended to sterilize food.
- Automated Report Documentation (ARD) Software Package:** Allows for complete two-way communication between the unit and a remote PC. Supported functions include programming, system diagnostics, operation, and downloading of data for HACCP compliance.
- Temperature Recorder:** A strip recorder provides a record of the units operating parameters during a cycle and the following holding period. The information recorded includes date, time, cycle identification, recipe name, and product core temperature at prescribed intervals.
- Label Printer:** Clearly label food product with a product name and information regarding the product's life cycle throughout the entire chilling/freezing process.
- Wire Rack (WR-1):** Removable wire racks allows use of fractional size pans or half size sheet pans.
- Second Food Probe:** One heated food probe is standard. A second heated food probe can be provided as an option.
- Thaw Cycle Module:** Allows unit to be operated as a thaw cabinet and includes a non-heated thaw probe.
 - Automatic Mode:** Air temperature is controlled by monitoring the food product using a non-heated probe. Once the product reaches 38°F the cycle is complete and the unit switches into holding mode.
- Mobile Units:** 6" high stainless steel legs are standard. Heavy duty duty 4" or 5" dia. casters, two with brakes, are optional.

INSTALLATION: A detailed installation manual is provided. It must be carefully followed to ensure proper operation and to protect your rights under the warranty.

WARRANTY: The warranty covers all parts found to be defective and the labor required to replace them for a period of one year from the date of shipment. The compressor only is covered for an additional period of four years, as a part only, no labor.

TRAINING AND ORIENTATION: Detailed installation and operating manuals are provided with the unit. As an option, operational training can be provided.

