



BLAST CHILLERS
(Roll-In, Remote Refrigeration)
Models: AP24BC250-3 / AP40BC350-3

JOB _____
 ITEM # _____
 QTY. REQUIRED _____

AIA FILE # _____

SPEC # _____

SPECIFICATIONS

SCOPE: This specification covers the models AP24BC250-3 and AP40BC350-3 HurriChill™ Blast Chillers. They are complete with all required controls and accessories. Remote condensing unit sold separately. Several options are also available.

GENERAL: The microprocessor control system provides a choice of operating cycles: soft chilling, hard chilling, holding, sterilizing, and defrost. One core temperature probe is provided for accurate control of temperature within the product. An optional strip recorder provides a record of the unit's operating parameters during the cycle and the following holding period. The information recorded includes date, time, cycle identification, product identification and product core temperature at prescribed intervals. Models AP24BC250-3 and AP40BC350-3 are each sized for one mobile rack (not included) holding up to (40) 12" x 20" x 2-1/2" deep food pans or up to (20) 18" x 26" sheet pans. Pass-thru models are available as an option.

PERFORMANCE: Blast chilling (soft or hard) lowers the food core temperature from 160°F to 38°F within 90 minutes. Chilling times will vary somewhat, depending on the food quantity, initial temperature, density, moisture content, specific heat, and type of container. The airflow has a high velocity, indirect pattern designed to cool all levels at identical rates. Time/temperature chilling rates meet or exceed all FDA and state regulations.

CONSTRUCTION: The chilling cabinet is constructed of polished type 304 stainless steel, with 3-1/4" of CFC-free, high density polyurethane insulation. The interior corners are fully rounded. The door is equipped with a removable magnetic gasket. All motors are sealed ball bearing wash-down type. The cabinet floor is insulated (1/2" CFC-free high density polyurethane) and is provided with an integral 3" long ramp to facilitate access. A minimum 15" clear space is required above the cabinet for service. A minimum 6" clear space is required on the control panel side of the cabinet for service. A minimum 12" clear space is required on the hinge side of the cabinet for door opening.

REFRIGERATION SYSTEM: The cabinet refrigeration system is complete with all components, including controls, evaporator and blower system. The evaporator is of the forced convection type and designed specifically for blast chilling operation. Air circulation motors, multi-fin and tube type coils, and fan guards are contained within the cabinet. Also included in the cabinet are the liquid line solenoid valve, thermostatic expansion valves, the inlet and outlet connections, and a drain connection. Access to the evaporator for cleaning shall be via a convenient hinged, swing-out ventilator panel. Fan motors have inherent overload protection and the fan blades are guarded to prevent injury.

MICROPROCESSOR CONTROL SYSTEM: The solid state electronic control panel is user friendly, easy to reach, and can be set for automatic or manual operation. The core probe continuously measures the product temperature during the chilling cycles. Easy to read VFD display and buzzer alarm are standard features. All settings are programmable by the operator. The standard operating cycles include the following:

- Soft Chilling:** The air temperature is held in the range of 28°F to 35°F, ideal for delicate food items. The chilling cycle is completed when the food core temperature reaches 38°F to 40°F.



- Hard Chilling:** The air temperature is lowered to 10°F. When the food core temperature reaches 60°F, the air temperature rises to a range of 28°F to 35°F. The chilling cycle is completed when the food core temperature reaches 38°F to 40°F.
- Thawing (Optional):** Air temperature is carefully monitored and alternates between gentle heat and refrigeration to safely thaw food product.
- Holding:** At the end of any cycle (soft chilling or hard chilling), the unit will automatically switch to a holding mode which will keep the food at 38°F until the cycle is stopped.

ADDITIONAL FEATURES:

- Defrost:** An automatic defrost cycle is factory preset and will initiate after each 24 hours of operation. A manual defrost override can be selected at any time at the user's discretion.
- Recipe Names:** Up to 150 recipe names can be programmed by the user.

BLAST CHILLERS (Roll-In, Remote Refrigeration)
Models: AP24BC250-3 / AP40BC350-3



Details and Dimensions



BLAST CHILLERS (Roll-In, Remote Refrigeration)

Models: AP24BC250-3 / AP40BC350-3

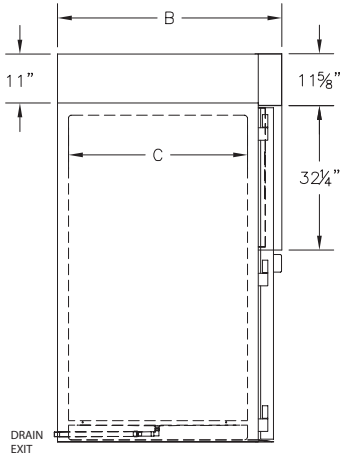

LATERAL VIEW

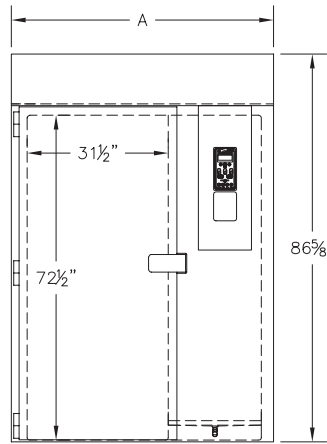

FRONT VIEW

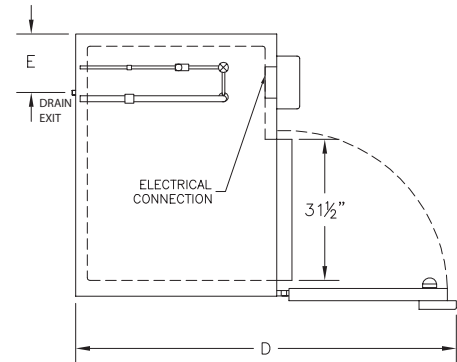

TOP VIEW

CABINET DATA	160°F TO 38°F FOOD LOAD PER CYCLE [LBS]	CABINET DIMENSIONS [IN]					CABINET ELECTRICAL					SHIPPING WEIGHT [LBS]
		MODEL	A	B	C	D	E	V	PH	HZ	A	
AP24BC250-3	250	54-3/8	46-1/4	35-3/4	81	11-1/4	208	3	60	8	15	1,240
AP40BC350-3	350	59	50-1/8	40	85	13-1/8	208	3	60	10	15	1,390

REFRIGERATION DATA	CAPACITY [BTU/H] AT: 14°F EVAP. TEMP 105°F COND. TEMP	REFRIGERANT	DISCHARGE LINE [IN] (UP TO 60 FT)	SUCTION LINE [IN] (UP TO 60 FT)	CONDENSING UNIT (OPTIONAL)
AP24BC250-3	25,000	404A	1/2	1-1/8	MEDIUM TEMP 40°F TO -10°F
AP40BC350-3	35,000		5/8	1-3/8	

OPTIONS:

- Sterilizing:** The ultraviolet system sterilizes all metal surfaces within the cabinet in a preset time of 30 minutes. The mirror finish of the cabinet interior is specifically designed to optimize the performance of the UV cycle. The system is not intended to sterilize food.
- Printer:** A strip recorder provides a record of the unit's operating parameters during a cycle and the following holding period. The information recorded includes date, time, cycle identification, recipe name, and product core temperature at prescribed intervals.
- Label Printer:** Clearly label food product with a product name and information regarding the product's life cycle throughout the entire chilling/freezing process.
- Four Food Probes:** One probe is standard. Four food probes can be provided as an option.
- Automated Report Documentation (ARD) Software Package:** Allows for complete two-way communication between the unit and a remote PC. Supported functions include programming, system diagnostics, operation, and downloading of data for HACCP compliance.
- Air-Cooled Remote Condensing Unit.**
- Water-Cooled Remote Condensing Unit.**
- Thaw Cycle Module:** Allows for thaw cabinet functionality and adds a non-heated thaw probe.
 - Automatic Mode:** Air temperature is controlled by monitoring the food product using a non-heated probe. Once the product reaches 38°F the cycle is complete and the unit switches into holding mode.
- Mobile Racks:** Model AP24BC250-3 can accommodate one mobile rack with maximum dimensions of 27" wide, 30-1/2" deep and 72" high. Model AP40BC350-3 can accommodate one mobile rack with maximum dimensions: 29" wide, 37" deep and 72" high.
- Rear Door:** For pass-thru operation (increases depth by 3")
- Prison Security Package.**

INSTALLATION: A detailed installation manual is provided. It must be carefully followed to ensure proper operation and to protect your rights under the warranty.

WARRANTY: The warranty covers all parts found to be defective and the labor required to replace them for a period of one year from the date of shipment.

