

Commercial Manual Dual Heat Press

The D-TXM-2-18 commercial manual dual-heat dough press's versatility in that it can be used with dual-heat, upper heat only or no heat, makes it the perfect choice for all types of products. The D-TXM-2-18 is press for medium to high volume production. It's heavy duty stainless steel construction and cam over-lock make it the top manual press in the industry. The dough press is an easy, affordable way to improve your production time, as well as your finished product. The D-TXM-2-18 is a swing away design with upper and lower heated platens.

Dual Heated Platens:

Pizza/Tortilla Dough

- speeds up production (faster pressing times)
- enables pressing thinner products
- aids dough flow
- allows dough to be pressed straight from refrigeration unit
- helps keep dough from shrinking back

Pizza Dough

- enables pressing thinner products
- aids in pressing sticky dough
- helps activate yeast for faster proofing if desired
- enables par baking pizza crust

Tortilla Dough

- initial grill off for tortillas

Variable Thickness Control

- makes it possible to achieve desired thickness and ensures consistent thickness at the same dough ball weight

Production:

- 18" platen allows for making variable crust sizes and thickness up to 18 inches – the size of the crust is determined by the weight of the dough ball and the thickness setting.
- depends on the desired size of the crust...9" to 18" = 150-200/hr, 7" to 9" = 300-400/hr, 6" or under = 600-800/hr

Finished Product:

- pressed dough keeps air in the crust vs. sheeted dough where the air is forced out of the crust. Pressed dough is consistent in thickness and size vs. hand tossed where the thickness and size can be inconsistent

Labor:

- presses require no skilled labor
- presses are safe and have no age requirements unlike sheeters/rollers

Use:

- D-TXM-2-18 is easy to use... prepare dough balls, set temp/thickness, place dough ball in center of lower platen, and press the dough.



Pressing Tips:

Tortilla Dough (Pre-Grill)

- Recommended Time: 1-3 seconds
- Recommended Temperature: 275°-325°

Par Bake Pizza Dough

- Recommended Time: Depends on percent par bake desired
- Recommended Temperature: 250°-350°

Fresh Pizza Dough

- Recommended Time: Warm dough, moderate to high yeast...2 seconds
Cold dough, moderate yeast...4-6 seconds
Cold dough, small amount of yeast...8 seconds
- Recommended Temperature: Warm dough...110°F, Cold dough...150°F



doughXpress

HIX Corporation Food Division

Product improvement may require us to change specifications without notice.

Revised July 2018

DOUGHXPRESS

1201 E. 27th Terrace
Pittsburg, KS 66762 USA

Toll Free: (800) 835-0606 ext.205

Tel: (620) 231-8568 ext.205

Fax: (620) 231-1598

doughxpress@hixcorp.com or visit www.doughxpress.com



Model No.

D-TXM-2-18

Commercial Manual Dual Heat Press

Features Include:

- cam over-lock linkage keeps upper platen in pressing position until handle is lifted by operator
- digital temperature control displays current reading
- digital timer (count down begins automatically when platen lowers and resets after the platen raises)
- thickness adjustment for various product thicknesses
- bottom swing out design saves space and is easier to use than top swinging models
- illuminated On/Off switch
- heat indicating light that turns off when set temperature is reached
- flattens dough balls into pizzas up to 18" in diameter
- stainless steel exterior with aluminum upper and lower platens
- sleek, modern, durable, easy to clean design

Optional Features:

- Non-stick PTFE coated upper and lower platens
- powder coated white finish

Certifications:

- ETL Electrical Safety
- ETL Sanitation

Recommended Cleaning Instructions:

- wipe down with a moist towel - if needed, use damp sponge with minimal soap and water and then dry off

DIMENSIONS

Width: 22-1/2 inches, 57.2 centimeters
Height: 31-3/8 inches, 79.7 centimeters
Depth: 30-7/8 inches, 78.4 centimeters

WEIGHT

Shipping: 250 lbs.

ELECTRICAL

220 Volt / 60 Hz
3100 Watts
15 Amps / Single Phase
6-20P NEMA Plug

TEMPERATURE RANGE

Off-450°F, 232°C upper platen

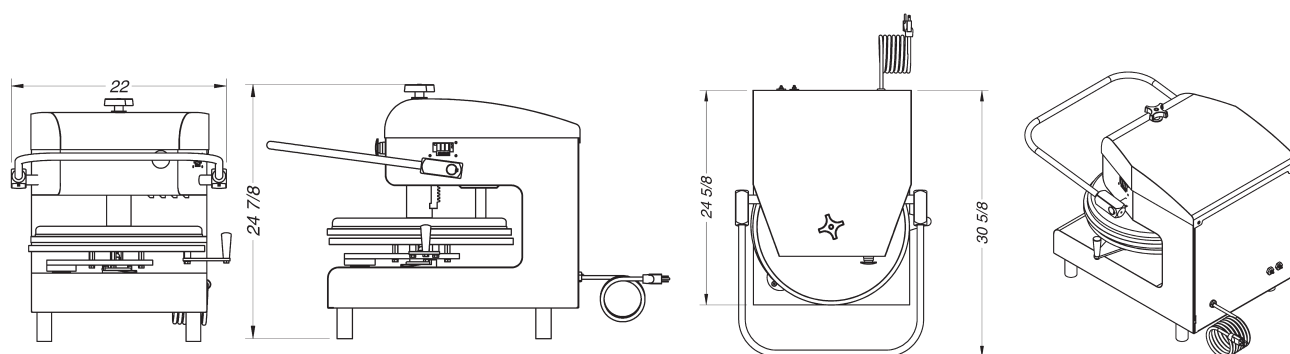

doughXpress

HIX Corporation Food Division
Product improvement may require us to change specifications without notice.
Revised July 2018

DOUGHXPRESS
1201 E. 27th Terrace
Pittsburg, KS 66762 USA

Toll Free: (800) 835-0606 ext.205
Tel: (620) 231-8568 ext.205
Fax: (620) 231-1598

doughxpress@hixcorp.com or visit www.doughxpress.com