



# TOWN



**TOWN FOOD SERVICE EQUIPMENT CO., INC.**  
72 BEADEL STREET, BROOKLYN, NY 11222  
Ph. (718) 388-5650 Fax (718) 388-5860  
(800) 221-5032 [www.townfood.com](http://www.townfood.com)

## STEAMER RANGE & CABINET



### GENERAL

The Town YF-STMR is a gas fired two compartment steamer range. It is self contained and requires only gas and water connections. The unit features "Town AutoFill" which will automatically maintain the proper water level in the steam tank and insure copious steam production. The unit is NOT thermostatically controlled. The primary usage is for cooking Asian foods, such as dumplings or dim sum. Foods such as whole fish or soup can be steamed in this unit. It can be used to cook any food that requires high, continuous, steam heat. Exterior of unit is constructed in 304 Stainless Steel. The steam generation tank is Stainless Steel, which has cast iron heat plates mounted on the tank bottom for faster heating and long tank life. The doors are double wall, insulated, complete with a positive latching mechanism. The interior fire chamber is constructed in steel angle iron and is fully insulated by 1" thick fiber ceramic material. Unit is fired by a high power 32 tip jet burner (116 MBTUH). A pilot safety gas valve is provided. The unit can be customized with different body and cabinet sizes, as well as custom dim sum steamer plates.

### MODELS

The base model is YF-STMR-SS. Natural or Propane fuel models are available.

### STANDARD FEATURES

- Listed by ETL to conform to ANSI Z83.11-2007
- Listed by ETL to conform to ANSI/NSF4
- 2 Door Stainless Steel Steam Cabinet with 4 shelves
- Stainless Steel Door Hinges/ Left or Right Hinging
- 4 Perforated Stainless Steel trays to hold product for steaming
- Stainless Steel , positive lock latches
- "Autofill" Water Tank with dump valve
- Steam tank access from top of unit for easy cleaning/de-scaling
- Single valve control with pilot safety device
- Stainless Steel legs with height adjustment "bullets"
- Rear drain connection
- Works with cold or hot water supply. Hot recommended
- Steam Tank dump valve
- Water cooled deck

### OPTIONS

- Custom size steam cabinets
- Custom size base unit
- Dim sum steamer plates to replace cabinet
- Drop or Slide in base units
- Manual faucet mounted on Backsplash

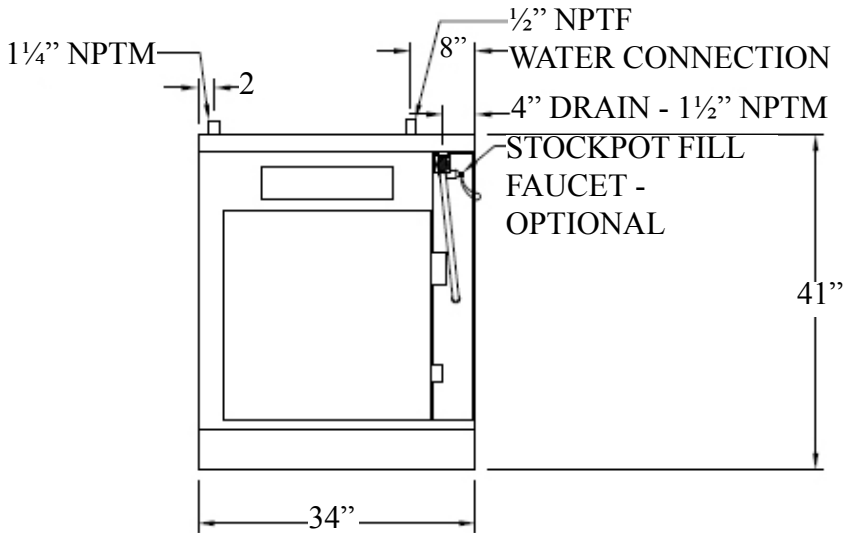

# YF-STMR-SS STEAMER RANGE

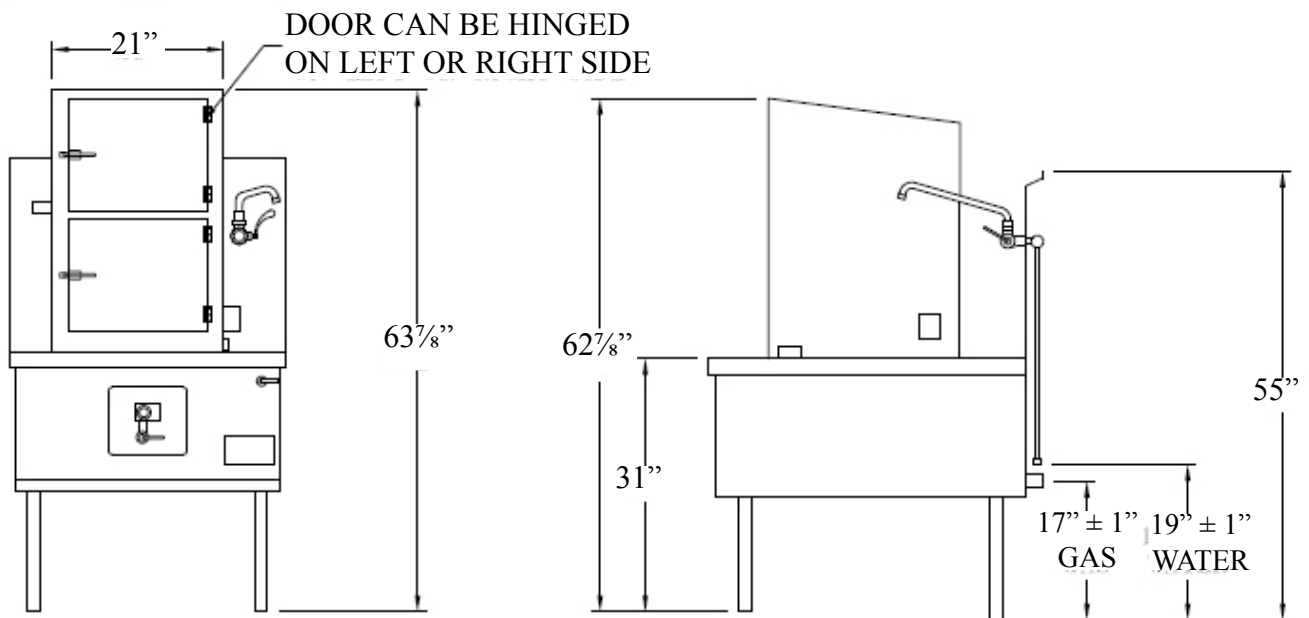

## IMPORTANT

Commercial gas range(s) must be installed in accordance with state and local codes, or in the absence of local code with the NATIONAL FUEL GAS CODE- ANSI Z223.1. COMPLIANCE WITH ALL CODES IS THE RESPONSIBILITY OF THE OWNER AND THE INSTALLER.

COMMERCIAL GAS UNITS NEED ADEQUATE VENTILATION SYSTEMS. REFER TO NATIONAL FIRE PROTECTION ASSOCIATION STANDARD NO 96- "VAPOR REMOVAL FROM COOKING EQUIPMENT"

CERTIFIED BY ETL TO CONFORM TO ANSI Z83.11- "GAS FOODSERVICE EQUIPMENT."  
NOT INTENDED FOR HOUSEHOLD USE. FOR USE BY PROFESSIONAL TRAINED PERSONNEL ONLY.

CERTIFIED BY ETL/NSF TO NSF4/ANSI-4-COMMERCIAL COOKING, RETHERMALIZATION AND HOT FOOD EQUIPMENT- "SANITATION."

MINIMUM CLEARANCES- COMBUSTIBLE AND NON COMBUSTIBLE:  
Back Wall- 6" Left and Right Sides- 6" For use on non combustibile floors only.

Town reserves the right to change design without notification.