

E**PREMIER SERIES HIGH
PERFORMANCE ELECTRIC
CONVECTION OVEN**

JOB NAME: _____

ITEM NO.: _____

NO. REQUIRED: _____



*3000 Shown on Stainless Steel Stand
and with Optional Glass Door*

MODEL: 3000

SIZE: 40" Wide X 62" High x 46" Front-to-Back
(1016mm Wide x1575mm High x 1168mm Front-to-Back)

DESCRIPTION: The Market Forge 3000 High Performance Convection Oven is designed to provide superior cooking with five-racks and even distribution of heat.

The design engineered baffle system combined with 11kW's adds up to higher volume production in less time with energy conservation in mind at all times.

The 3000 Convection Oven provides many standard features that are optional in other brands. Stainless Steel handle adds to the rugged construction and beauty of your kitchen. If you're looking for premium quality and commitment to performance, you can rely on the High Performance Electric Convection Oven.

STANDARD FEATURES:

- Design Engineered Anti-Static Thermal Features.
- 11 kW's for high performance cooking and production.
- Porcelainized interior for easy maintenance.
- Twelve rack positions with five racks.
- Durable 1/2 H.P. 2 speed motor.
- 50/50 doors, one hand opens both doors.
- Stainless Steel Front, sides, top.
- Stainless Steel Solid Doors. N/C
- Stainless Steel Door gasket, for long lasting service.
- Two interior lights, with momentary switch.
- Stainless Steel adjustable legs.
- 60 minute timer with audible buzzer.
- One year parts and labor warranty.
- Cool Down Switch.
- Temperature Range 150° to 500°F.
- One Power Supply.

The manufacturer reserves the right to modify materials and specifications without notice.

Spec No. S-6141
06/05**FOOD SERVICE EQUIPMENT**
Premier Series Oven**MARKET FORGE**
INDUSTRIES INC.*An Employee Owned Company*

35 Garvey Street • Everett • MA • 02149
Tel: (617) 387-4100 • Fax: 1-800-227-2659 (Ex. MA) • (617) 387-4456 (MA and Overseas)
E-Mail: CUSTSERV@mfi.com • Website: www.mfi.com

E**PREMIER SERIES HIGH PERFORMANCE ELECTRIC CONVECTION OVEN****DETAILS & DIMENSION****CLEARANCE REQUIRED:**

When installing ovens against combustable surfaces 6" 152mm clearance is required.

When installing ovens against non-combustable surfaces (rear or side walls) 0" clearance is required.

OPTIONAL AT EXTRA COST:

- Stainless Steel Bottom Shelf and Rack Supports.
- Stainless Steel Bottom Shelf Only.
- Extra Oven Rack.
- Casters, (2) with Breaks.
- One Glass Door.
- 480 Volt, 3pH.

SERVICE CONNECTIONS**Electrically Operated**

EC	Electrical Connection - Connection for incoming power supply wire on terminal block.		
EP	Power supply - 1 3/8 (44mm) Ø access holes for power supply wires. Use wire suitable for at least 90°C. Nominal amp per line wire per oven: 11 kW		
VOLTS	1pH	3pH	
208V	53	31	
240V	46	27	
480V	—	15	

Details of other electrical systems available upon request.

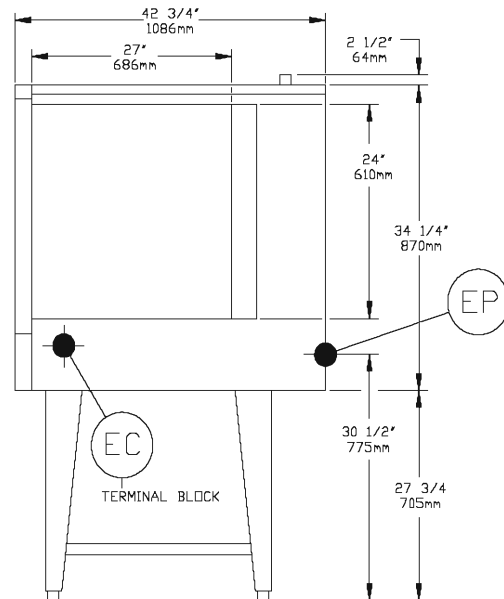
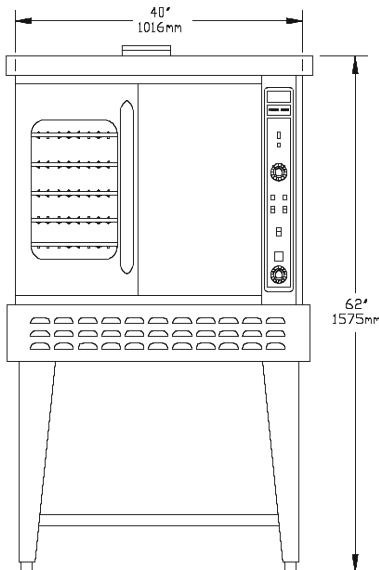
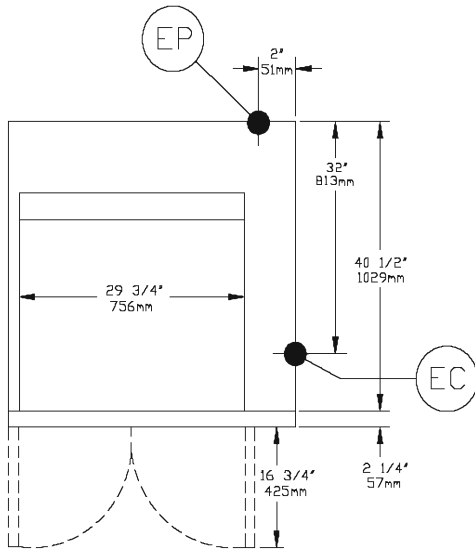

*It is our policy to build equipment which is design certified by ETL Certified, U.L. and UL Sanitation. However, a continuing program of product improvement makes it necessary to submit new models to the agencies as they are developed and consequently not all models bear the appropriate agency labels at all times.

Spec No. S-6141
06/05

FOOD SERVICE EQUIPMENT
Premier Series Oven



MARKET FORGE
INDUSTRIES INC.

An Employee Owned Company



Printed in U.S.A.

35 Garvey Street • Everett • MA • 02149
Tel: (617) 387-4100 • Fax: 1-800-227-2659 (Ex. MA) • (617) 387-4456 (MA and Overseas)
E-Mail: CUSTSERV@mfi.com • Website: www.mfi.com