

**E****UNIVERSE PLUS  
ELECTRIC TILTING SKILLET**JOB NAME: \_\_\_\_\_  
ITEM NO.: \_\_\_\_\_  
NO. REQUIRED: \_\_\_\_\_MODELS:     30P-STEL     40P-STEL  
               30P-STEM     40P-STEM**DESCRIPTION:**

The Market Forge Electric Universe Plus Tilting Skillets are available in 30-gallon (87-liter) and 40-gallon (114-liter) pan bodies with 12kW and 18 kW inputs respectively. Both models are available in open-leg and closed-base frame assemblies with manual or power tilt capabilities.

The heavy duty construction of our Universe Plus Skillets incorporate sides formed of 10 gage stainless steel and a 5/8" thick stainless steel clad plate that will provide a rigid flat cooking surface with improved heat distribution. The balanced design of the pan allows the operator to easily and quickly tilt to the desired position. Our new power tilt operates smoothly, with manual override that works easily when needed and without the use of tools or drills as required by other manufactures.

**Construction:**

The Universe Plus Skillet has a fully polished stainless steel cooking surface that reduces food from adhering and helps to safely clean the equipment. Heaters turn off automatically when the cooking pan is tilted from the horizontal position. The skillet is provided with a heavy-duty spring assisted cover with a condensate vent. The cooking pan and cover are supported by two consoles with a fully welded stainless steel tubular frame system that provides stable support to the unit.

The consoles are completely covered with stainless steel that provides protection to the controls and is also easily cleanable and provides clear access for easy floor cleaning. The closed-base model incorporates an easily removable stainless steel front and rear panel. The sloped front of the pan allows for complete draining of the pan when tilted to 70°. The tilting mechanism includes a precision ground and polished worm for smooth and long lasting tilt operation and positive control with a collapsible hand crank. A power tilting option is available and is also supplied with the collapsible handle for manual override operation if required.

**TECHNICAL SPECIFICATIONS:****Cooking Pan:**

The unitized cooking pan with integral clad plate cooking surface is welded with full penetration to resist cracking due to expansion and contraction. The polished cooking surface resists product adherence and improves cleanup and appearance. The pan incorporates an easy-pour lip and

*30P-STEL Shown*

5-gallon increment markings. The clad plate cooking surface has electric tubular elements attached to the bottom of the pan for even and efficient heat transfer. An interlock switch is provided to turn the heaters off when the pan is tilted more than 10° from the normal horizontal position. The spring assisted cover with integral vent, condensate drip guide and full width handle affords effortless operation and will maintain an open position.

**Controls:**

The skillet comes standard with a solid-state temperature control with a positive OFF position and 100°-450° Fahrenheit scale, a pilot light to indicate when the elements are ON, and a 1 hour mechanical timer. The optional power tilting mechanism also utilizes an UP/DOWN rocker switch. The manual tilting mechanism uses a collapsible hand crank conveniently located below the control panel. The controls are resistant to dripping and light splashing water (NEMA T-2).

**OPERATION SHALL BE BY:**

All UniVerse Plus Tilting Skillets models are available in 208VAC, 240VAC, field convertible to 1 or 3 phase, or 480VAC 3 phase. 30 Gallon models are rated at 12 kW and the 40 Gallon models are rated at 18 kW.

The manufacturer reserves the right to modify materials and specifications without notice

Spec No. S-4325  
01/05FOOD SERVICE EQUIPMENT  
Universe Plus Tilting Skillet**MARKET FORGE**  
INDUSTRIES INC.*An Employee Owned Company*35 Garvey Street • Everett • MA • 02149  
Tel: (617) 387-4100 • Fax: 1-800-227-2659 (Ex. MA) • (617) 387-4456 (MA and Overseas)  
E-Mail: CUSTSERV@mfi.com • Website: www.mfi.com

**E****UNIVERSE PLUS  
ELECTRIC TILTING SKILLET**

DETAILS &amp; DIMENSION

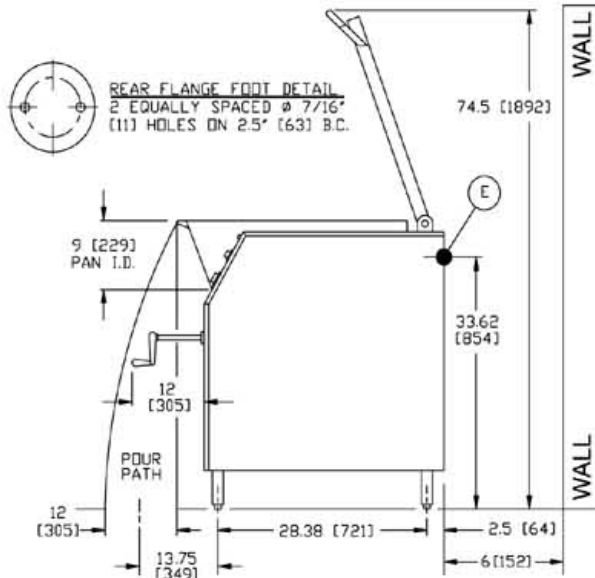
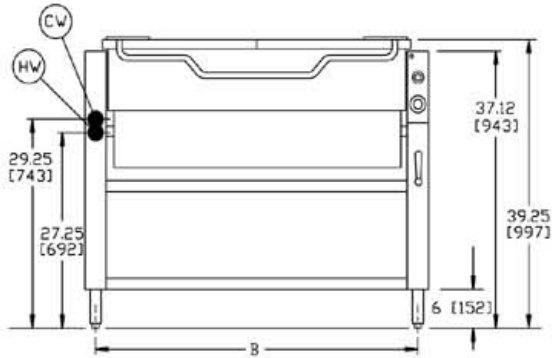
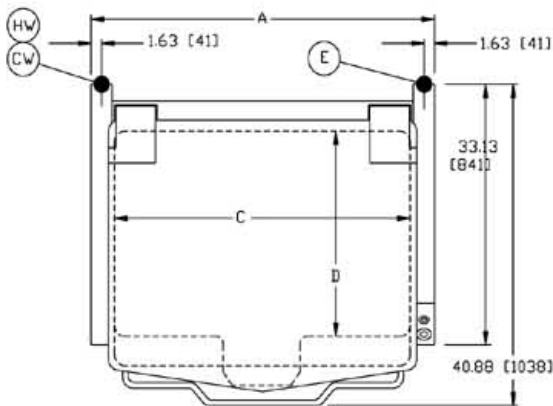
**SERVICE CONNECTIONS****Electrically Operated**

E	Electrical Connection - Use wire suitable for 90°C. A stepdown transformer provides power to the 120V control circuit.				
		40P-STEM & 40P-STEL (18 kW)		30P-STEM & 30P-STEL (12 kW)	
	VOLTS AC	1 pH	3 pH	1 pH	3 pH
	208	87	50	58	33
	240	75	43	50	29
	480 (3 pH Only)	--	22	--	14.5
Details of other electrical systems are available upon request.					
CW	Cold Water - 3/8" O.D. NPT to faucet (Optional).				
HW	Hot Water - 3/8" O.D. NPT to faucet (Optional).				

**OPTIONAL AT EXTRA COST:**

- 2" Draw-Off Valve w/Strainer
- Modular Joining Kit
- Pan Support
- Pan Holder Inserts
- Pouring Lip Strainer
- Single Pantry Faucet
- Posi-Set
- 2" Tangent Draw-Off Valve with Drain Hose Assembly, Includes:
  - 2" Tangent Draw-Off Valve with Strainer
  - 90° Stainless Steel Elbow
  - 8 Foot Long of 2" ID Hose (cut to required length)
  - Hose Clamp
- Drain Cup Assembly, Includes:
  - Stainless Steel Cup Assembly
  - 8 Foot Long of 2" ID Hose (cut to required length)
  - Hose Clamp
- Drain Pan Assembly, Includes:
  - 6" x 12" x 20" Stainless Steel Solid Pan with Elbow
  - 8 Foot Long of 2" ID Hose (cut to required length)
  - Hose Clamp
- Double Pantry Faucet
- Single Pantry Spray Hose
- Double Pantry Spray Hose
- Caster Kit w/Strain Relief
- Correctional Package

**DIMENSIONS**

MODEL	CAPACITY		A	B	C	D
30P-STEL	30 Gallon	inches	36	34.63	30.5	25.75
30P-STEM	114 liter	mm	914	879	775	654
40P-STEL	40 Gallon	inches	46	44.63	40.5	25.75
40P-STEM	152 liter	mm	1168	1133	1029	654

**CLEARANCE:**                      **12 kW**                      **18 kW**

- Left Side                      0"                      0"
- Right Side                      0"                      0"
- Back                      6"                      6"

\*It is our policy to build equipment which is design certified by N.S.F., N.E.M.A. and C.S.A. However, a continuing program of product improvement makes it necessary to submit new models to the agencies as they are developed and consequently not all models bear the appropriate agency labels at all times.

Spec No. S-4325  
01/05FOOD SERVICE EQUIPMENT  
Universe Plus Tilting Skillet**MARKET FORGE**  
INDUSTRIES INC.

An Employee Owned Company



Printed in U.S.A.

35 Garvey Street • Everett • MA • 02149  
 Tel: (617) 387-4100 • Fax: 1-800-227-2659 (Ex. MA) • (617) 387-4456 (MA and Overseas)  
 E-Mail: CUSTSERV@mfi.com • Website: www.mfii.com