

MSS MOBILE STAND

JOB NAME: _____

ITEM NO.: _____

NO. REQUIRED: _____

MODELS

- MSS Mobile Stand with Work Shelf and Tray 92-1012

DESCRIPTION

Stand is constructed of stainless steel with all welded construction. The stand is supplied with swivel casters, two with brakes. The stand is 30" high and comes assembled. The top is fitted with four (4) foot clips for placement for a 4- or 6-pan steamer. Foot clips position the steamer and keep the steamer from moving on the top of the stand.

Stand is equipped with a pull-out shelf with a built-in stop to provide a fourteen (14) inch deep work surface at the front of the steamer. The stop is designed as a lever to easily remove the shelf for sink cleaning. Shelf can move in a stainless steel U bracket with neoprene glides. A welded stainless steel shelf is provided at the base of the stand for storage. Stand can accommodate a pan rack assembly that holds ten 2" pans.

OPTIONAL AT EXTRA COST

- Pan Rack (PRM) Holds (10) 2" Removable Pans (for 92-1014 & 92-1012 stands only)



CHARACTERISTICS:	92-1012
Overall Width	24" (610mm)
Overall Depth	28" (711mm)
Overall Height + Legs	34.5" (876mm)
No. of Shelves	1
Shelf Area (Square Feet)	2.05
No. of 2" Pans (PRM 92-1013)	Holds 10

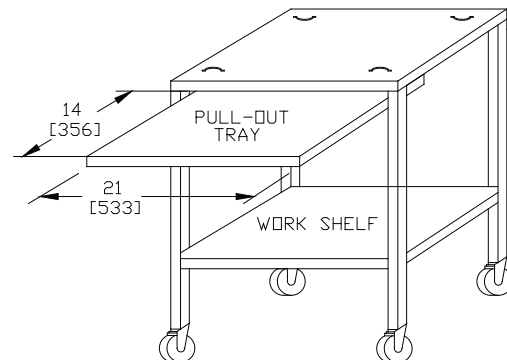
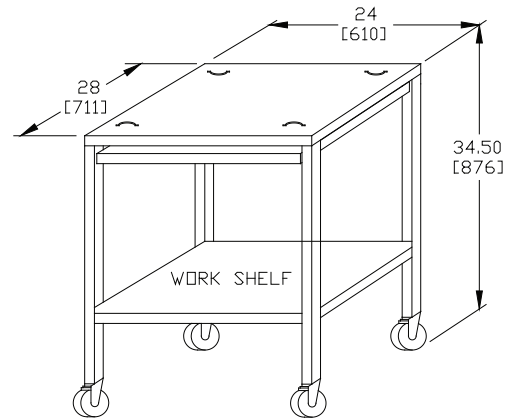

The manufacturer reserves the right to modify materials and specifications without notice.

FOOD SERVICE EQUIPMENT
Mobile Stand with Work Shelf & Tray

X**MODEL NAME**

DETAILS & DIMENSIONS

SERVICE CONNECTIONS

G	Gas Connection - x
CW	Cold Water - x
D	Drain - x
EC	Electrical Connection - x

INSTALLATION CLEARANCE

Left Side	Right Side	Rear
x	x	x

ELECTRICAL CHARACTERISTICS

MODEL	kW	Hz	1 Phase		3 Phase	
			208V	240V	208V	240V
XX	x	x	x	x	x	x
	x	x	x	x	x	x

FOOD SERVICE EQUIPMENT

x

x
x
x
x

It is our policy to build equipment which is design certified by C.S.A. and N.S.F. However, a continuing program of product improvement makes it necessary to submit new models to the agencies as they are developed and consequently not all models bear the appropriate agency labels at all times.



MARKET FORGE
INDUSTRIES INC.