



MOBILE STAND

JOB NAME: _____
 ITEM NO.: _____
 NO. REQUIRED: _____



Mobile Stand STSM (92-1021)

MODEL: STSM / Part No. 92-1021

DESCRIPTION:

The STSM 16-5/8" Stand is constructed of stainless steel with all welded construction. The stand is supplied with a set of four (4) swivel casters, two (2) with brakes. Unit shall be used for 6- and 8-pan steamers.

Unit comes assembled. Top is fitted with four (4) foot clips for placement of Altair II or Sirius II steamer. Foot clips position the steamer and keep the steamer from moving on the top of the stand. Standard features include, rigid all stainless steel construction, welded construction, shipped assembled, and foot clips on top surface for unit placement.

CHARACTERISTICS:	92-1021
Overall Width	24" (610mm)
Overall Depth	28.5" (724mm)
Overall Height + Casters	16-5/8" (422mm)

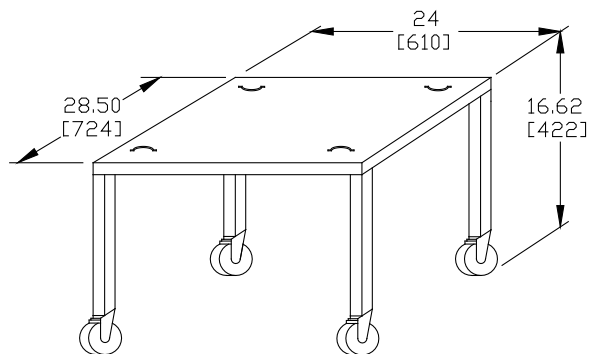

The manufacturer reserves the right to modify materials and specifications without notice.

It is our policy to build equipment which is design certified by U.L., C.S.A. and N.S.F. However, a continuing program of product improvement makes it necessary to submit new models to the agencies as they are developed and consequently not all models bear the appropriate agency labels at all times.

SPEC SHEET: S-6179
09/13

FOOD SERVICE EQUIPMENT
Mobile Stand



MARKET FORGE

INDUSTRIES INC.

PRINTED IN U. S. A.

35 Garvey Street • Everett • MA • 02149-4403
 Tel: (617) 387-4100 • Toll Free: (866) 698-3188
 Fax: (617) 387-4456 (MA and Overseas) • Fax: (800) 227-2659 (Ex. MA)
 E-mail: custserv@mfi.com • www.mfi.com