

D

DIRECT STEAM STATIONARY PEDESTAL BASE KETTLE

JOB NAME: _____

ITEM NO.: _____

NO. REQUIRED: _____

MODELS

- F-20P - 20 gallon (76 liter), direct steam, stationary, pedestal
- F-30P - 30 gallon (114 liter), direct steam, stationary, pedestal
- F-40P - 40 gallon (152 liter), direct steam, stationary, pedestal
- F-60P - 60 gallon (227 liter), direct steam, stationary, pedestal
- F-80P - 80 gallon (303 liter), direct steam, stationary, pedestal
- F-100P - 100 gallon (380 liter), direct steam, stationary, pedestal

DESCRIPTION

Will be a Market Forge direct steam connected, pedestal steam jacketed kettle constructed of welded satin finish stainless steel, type 304. A double wall kettle interior will form a 2/3 steam jacket around the lower of the kettle. The kettle bottom will be of elliptical design for superior heat circulation. The F-20, 30 & 40 gallon kettles come standard with a 316 type stainless steel inner liner. The F-60, 80 & 100 gallon kettles come standard with a 304 type stainless steel inner liner.

The pedestal base shall have 7/16" (11mm) holes evenly spaced for securing unit to the floor.

Unit will include as standard a steam control kit (STA-1), which includes a steam trap, steam inlet globe valve, check valve, and a line strainer. Unit comes standard with 2" tangent draw-off valve with perforated strainer, and a spring assist hinged stainless steel cover with a heat resistant handle.

OPERATION WILL BE BY:

Direct steam source at a minimum of 5 PSI (34kPa) and a maximum of 30 PSI (241kPa). Kettles are built as standard with a MAWP of 35 PSI.

STEAM FLOW REQUIREMENTS:

34 lbs. (15.5 kg) steam pre hour or 1 BHP per 20 gallons (76 liters) of kettle capacity.

MODEL	BHP/HR	LBS STEAM/HR
F-20P	1.0	34.5
F-30P	1.5	52.0
F-40P	2.0	69.0
F-60P	3.0	103.5
F-80P	4.0	138.0
F-100P	5.0	172.5

SHIPPING WEIGHT

- F-20P - 225 lbs (102 kg)
- F-30P - 245 lbs (111 kg)
- F-40P - 270 lbs (122 kg)
- F-60P - 295 lbs (134 kg)
- F-80P - 320 lbs (145 kg)
- F-100P - 345 lbs (156 kg)



F-20P shown

OPTIONS & ACCESSORIES

(at additional charge)

- **Pantry Faucet**
 - 12" double pantry faucet w/swing spout & bracket
 - 12" single pantry faucet w/swing spout & bracket
 - 18" double pantry faucet w/swing spout & bracket
 - 18" single pantry faucet w/swing spout & bracket
 - Double kettle filler
 - Single kettle filler
 - Double faucet spray hose kit w/bracket & plumbing
 - 60" water hose with quick disconnect
 - Faucet bracket
- Etched gallon markings
- BFT (ball float trap)
- Quick chill
- Tri-basket strainer
- 3" (76mm) draw-off valve with strainer
- Graduated measuring stick
- Wall models (consult factory)
- Type 316 s/s liner (for high acid content over 40 gallons)
- MAWP of 50 PSI (345kPa) for high pressure operation for higher cooking temperature
- PRV pressure reducing valve
- Prison package, s/s plate over tangent draw-off valve, tamper proof screws, chrome plated steam control, lockable s/s spring assist hinged cover, reinforcement bar



D

DIRECT STEAM STATIONARY PEDESTAL BASE KETTLE

DETAILS & DIMENSIONS

DIMENSIONS

MODEL	A	B	C	D*	E	F (2")	F (3")	G (2")	G (3")	H	J	K
F-20P	21 [533]	18 [457]	37 [940]	22.75 [578]	16 [406]	12.75 [324]	14 [356]	17 [432]	16.5 [419]	25.88 [657]	59.75 [1518]	16.88 [429]
F-30P	24 [610]	20 [508]	37 [940]	25.88 [657]	17.5 [445]	13.5 [343]	15.25 [387]	15 [381]	14.5 [368]	26.88 [683]	62.88 [1597]	16.88 [429]
F-40P	26 [660]	22.5 [572]	37 [940]	27.88 [708]	18.5 [470]	14.25 [362]	16.5 [419]	12.5 [318]	12 [305]	23.88 [606]	64.88 [1648]	16.88 [429]
F-60P	29.5 [749]	26 [660]	40.5 [1029]	31.38 [797]	17.75 [451]	15.5 [394]	17.25 [438]	12.5 [318]	12 [305]	24.69 [627]	72.88 [1851]	16.88 [429]
F-80P	33 [838]	28 [711]	42.5 [1080]	34.75 [883]	19.5 [495]	17.5 [445]	19.25 [489]	10.5 [267]	10 [254]	23.88 [606]	75.25 [1911]	19.63 [498]
F-100P	35.5 [902]	30 [762]	44.5 [1130]	37.25 [946]	20.75 [527]	17 [432]	19.25 [489]	12.5 [318]	12 [305]	26.63 [676]	81.75 [2076]	19.63 [498]

* Add 6" if optional faucet is used.

SERVICE CONNECTIONS

S	Steam Supply - 3/4" NPT (19mm) at 5-30 PSI (0.3-2.1 kg/cm ²). Optional 5-45 PSI (0.3-3.1 kg/cm ²).*
CR	Condensate Return - 1/2" NPT (13mm)
HW	Hot Water - 5/8" O.D. Tubing (Optional)
CW	Cold Water - 5/8" O.D. Tubing (Optional)

* A pressure reducing valve is required if incoming pressure exceeds the MAWP rating of kettle.

MODEL	SPRING ASIST HINGES
Gallons	MIN. CLEARANCE
ALL	SIDES 3 [76]
	BACK 0.5 [13]

DIMENSIONS ARE IN INCHES [MM]

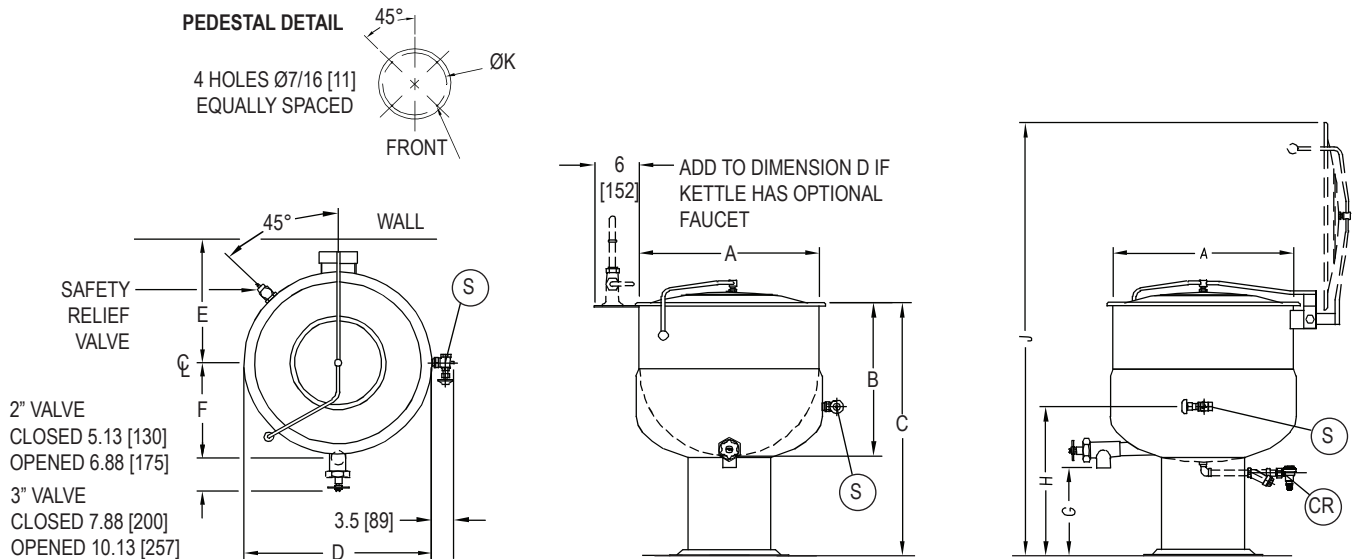

The manufacturer reserves the right to modify materials and specifications without notice.

mf WORLDWIDE **MARKET FORGE**

PRINTED IN U. S. A.
SPEC SHEET: 14-0135 Rev C (12/15)

AutoQuotes

Tel: (802) 658-6600 • Fax: (802) 864-0183 • www.marketforge.com