

G**2/3 JACKETED TILTING
GAS KETTLE**

JOB NAME: _____

ITEM NO.: _____

NO. REQUIRED: _____

MODELS

- FT-20GL - 20 gallon, gas tilting kettle
- FT-30GL - 30 gallon, gas tilting kettle
- FT-40GL - 40 gallon, gas tilting kettle
- FT-60GL - 60 gallon, gas tilting kettle

DESCRIPTION

The kettle has double-wall construction of 300 series stainless steel forming a steam jacket around the lower 2/3 of the kettle. The jacket enclosure contains factory sealed water and antifreeze. The kettle exterior is fully insulated. The bottom of the kettle is a hemispherical design for superior heat circulation. The recessed control panel is located on the front right side of the unit in full view of the operator. Standard controls include direct immersion thermostat, water sight glass, cooking light, pressure gauge and electronic ignition with ignition indicator light. Safety features include low water cutoff with indicator light, pressure switch, pressure relief valve and a 100% safety gas shut off valve.

The kettle pivots on trunnions connected to the gear and control consoles. The worm and gear tilting mechanism allows the kettle to tilt forward to a full 90° for complete draining. The tilt mechanism is self locking for positive stop action. The consoles are drip proof, stainless steel clad and are supported on all welded 1 5/8" (41mm) diameter stainless steel legs with flanged feet.

The kettle construction is stainless steel throughout and built in accordance with the ASME code. 20, 30 and 40 gallon kettles will have 316 type stainless steel liner as standard.



FT-40GL shown with optional Spring assist cover

OPTIONS & ACCESSORIES

(at additional charge)

- **Pantry Faucet**
 - 18" Single pantry faucet with swing spout
 - 18" Double pantry faucet with swing spout
- **Tangent Draw-off**
 - 2" tangent draw off, FDOR-2
 - 3" tangent draw off, FDOR-3
- Spring assist cover, HSC
- Tri-Basket assembly
- Graduated measuring strip, MS-1
- Perforated strainer
- Solid disk strainer DOS-2
- Lip strainer
- Type 316 Stainless Steel Liner for High Acid Content Products for 60 gallon kettles (standard on 20, 30 and 40 gallon kettles)

MODEL	Input BTU/Hour	Combustion Efficiency
FT-20GL	80,000	78% Minimum
FT-30GL	100,000	78% Minimum
FT-40GL	100,000	75% Minimum
FT-60GL	120,000	75% Minimum

OPERATION WILL BE BY

Natural or L.P. gas utilizing a high efficiency power burner system. The steam kettle is A.S.M.E. code stamped for operation to 50 PSI. Temperature range from 150°F to 285°F.

The controls shall be equipped for operation on 120 VAC, 1pH, 50/60 Hz.

SHIPPING WEIGHT

- FT-20GL - 700 lbs (318 kg)
- FT-30GL - 775 lbs 352 kg)
- FT-40GL - 850 lbs (386 kg)
- FT-60GL - 1000 lbs (454 kg)

FOOD SERVICE EQUIPMENT
Tilting Gas Kettle
**MARKET FORGE**

G

2/3 JACKETED TILTING GAS KETTLE

DETAILS & DIMENSIONS

DIMENSIONS

MODEL	A	B	C	D	E	F	G	H	J	K	L	M	N
FT-20G	20 [508]	18.38 [467]	48.13 [1222]	40.75 [1035]	40.13 [1019]	70 [1778]	19.75 [502]	14.63 [371]	25.5 [648]	11.38 [289]	22 [559]	40.5 [1029]	22.75 [578]
FT-30G	26 [660]	17.75 [451]	55.25 [1403]	43.75 [1111]	39 [991]	74.88 [1902]	19.13 [486]	17.13 [435]	28.5 [724]	8.38 [213]	21 [538]	38.13 [968]	22.75 [578]
FT-40GL	26 [660]	22.13 [562]	55.25 [1403]	43.75 [1111]	43.25 [1099]	77.38 [1965]	19.13 [486]	17.13 [435]	28.5 [724]	8.38 [213]	23 [584]	42.5 [1080]	22.75 [578]
FT-60GL	30 [762]	24.75 [629]	59 [1499]	45.75 [1162]	46.63 [1184]	83.88 [2130]	19.88 [505]	18.88 [479]	30.5 [775]	6.38 [162]	23 [584]	25.5 [1156]	22.75 [578]

SERVICE CONNECTIONS

EC	Electrical Connection - Unless otherwise specified, field wire electrical connection to be 120 volts, 60 Hz, single phase with grounding wire. Unit furnished with 8' cord and 3 prong plug. Total max amps 4.0.
G	Gas Connection - Supply through 3/4" pipe. A gas shut-off valve must be installed in supply piping convenient and adjacent to appliance
H & C	Hot & Col Water Connection - 3/8" [10mm] tubing to faucet

GAS SUPPLY

MODEL	BTU/Hour	kW/hr	Supply Pressure	
FT-20GL	80,000	23.4	Natural	Propane
FT-30GL	100,000	29.3		
FT-40GL	100,000	29.3	6" - 14" (152-356mm)	11" - 14" (279-356mm)
FT-60GL	120,000	35.2		

MINIMUM CLEARANCE

Sides = 0", Back = 4 [102]

FOOD SERVICE EQUIPMENT
Tilting Gas Kettle

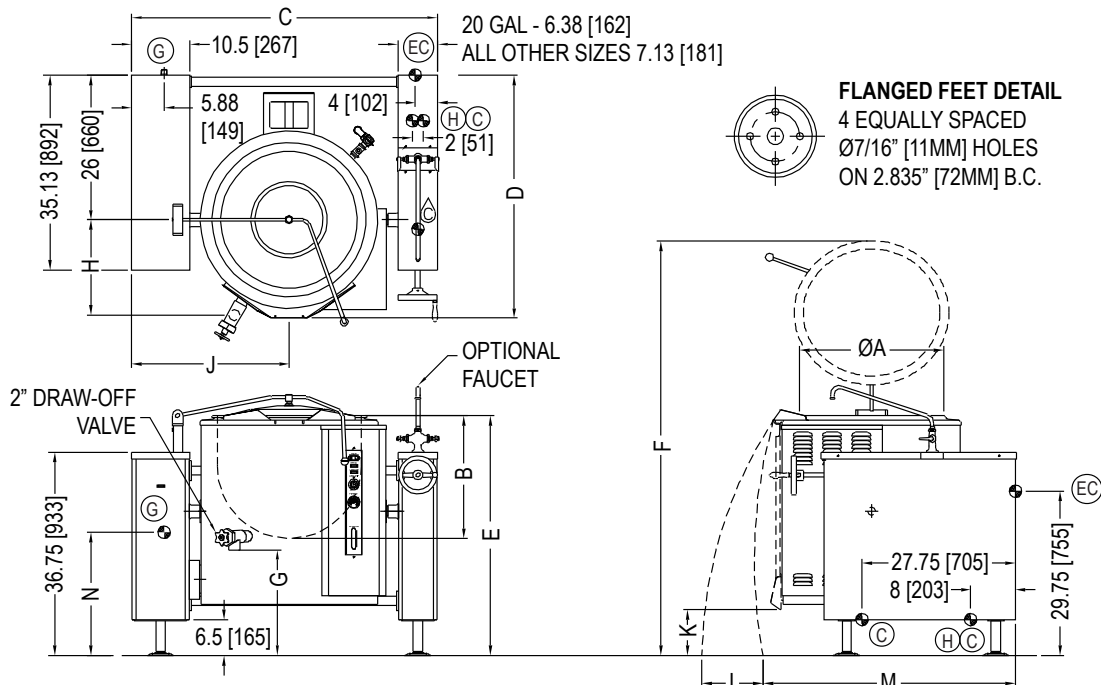

The manufacturer reserves the right to modify materials and specifications without notice.



PRINTED IN U. S. A.
SPEC SHEET: 14-0220 Rev E (8/18)



Tel: (802) 658-6600 • Fax: (802) 864-0183 • www.marketforge.com