

E**2/3 JACKETED TILTING
ELECTRIC TRI OR QUAD LEG KETTLE**

JOB NAME: _____

ITEM NO.: _____

NO. REQUIRED: _____

MODELS

- FT-20LE - 20 gallon (76 liter) electric, tri-leg, tilting kettle
- FT-25LE - 25 gallon (95 liter) electric, tilting tri-leg kettle
- FT-30LE - 30 gallon (114 liter) electric, tri-leg, tilting kettle
- FT-40LE - 40 gallon (152 liter) electric, tri-leg, tilting kettle
- FT-60LE - 60 gallon (227 liter) electric, quad-leg, tilting kettle
- FT-80LE - 80 gallon (303 liter) electric, quad-leg, tilting kettle
- FT-100LE - 100 gallon (380 liter) electric, quad-leg, tilting kettle

DESCRIPTION

Will be a Market Forged Self-generating electric, tri or quad leg tilting steam jacketed kettle. Kettle will be constructed of welded satin finish, stainless steel type 304. A double wall kettle interior will form a steam jacket around the lower 2/3 of the kettle. The jacket will enclose heating elements (Which will be easily removable for service), water and antifreeze design for superior heat distribution. 20, 25, 30 and 40-gallon kettles will have 316 type stainless steel liner as standard.

Unit will be mounted on a stainless steel tri and quad leg pipe fitted legs and adjustable flanged feet with four holes for securing kettle to floor.

Controls will be integrally mounted to the kettle base and will include a power switch, thermostat, pilot light, vacuum/pressure gauge, safety valve, and low water shut-off.

Kettle will operate in a temperature range of 165°F (74°C) to 285°F (140°C) at a maximum pressure of 50 PSI (345kPa).

OPERATION WILL BE BY:

Electrically, self-generating, closed steam system built in accordance with A.S.M.E. codes, and equipped for operation on:

- 208 VAC, 3 phase, 50/60 Hz
- 240 VAC, 3 phase, 50/60 Hz
- 480 VAC, 3 phase, 50/60 Hz*
- 220/380 VAC, 3 phase, 4 wire 50 Hz*
- 240/415 VAC, 3 phase, 4 wire 50 Hz*

*Optional at extra cost

SHIPPING WEIGHT

- FT-20LE - 296 lbs (134 kg)
- FT-25LE - 306 lbs (139 kg)
- FT-30LE - 313 lbs (142 kg)
- FT-40LE - 352 lbs (160 kg)
- FT-60LE - 417 lbs (189 kg)
- FT-80LE - 520 lbs (236 kg)
- FT-100LE - 630 lbs (286 kg)



FT-40LE shown with optional draw-off valve

OPTIONS & ACCESSORIES

(at additional charge)

■ Pantry Faucets

- 12" double pantry faucet w/swing spout & bracket
- 12" single pantry faucet w/swing spout & bracket
- 18" double pantry faucet w/swing spout & bracket
- 18" single pantry faucet w/swing spout & bracket
- Double kettle filler
- Single kettle filler
- Double faucet spray hose kit w/bracket & plumbing
- 60" water hose with quick disconnect
- Faucet bracket

■ Draw-Off Valve

- 2" (50mm) Draw-Off Valve with Strainer
- 3" (76mm) Draw-Off Valve with Strainer
- Triple Basket Assembly
- Graduated Measuring Stick
- Type 316 Stainless Steel Liner for High Acid Content Products for 60, 80 and 100-gal. kettles
- Counter Balanced Spring Assisted Hinged Cover
- Etched Gallon Markings
- 33 kW High Wattage 60, 80 and 100 gallon Kettles
- Prison package, s/s plate over tangent draw-off valve, tamper proof screws, lockable s/s spring assist hinged cover, reinforcement bar
- Pan Support
- Lip Strainer
- Kettle Brush Utensil Kit
- Export Voltages - 480 volt

FOOD SERVICE EQUIPMENT
Tilting Tri or Quad Leg Kettle

**MARKET FORGE**

E

2/3 JACKETED TILTING ELECTRIC TRI OR QUAD LEG KETTLE

DETAILS & DIMENSIONS

ELECTRICAL CHARACTERISTICS

AVAILABLE kW						KW	PHASE	AMPS PER LINE					
Model	Std	Option	Model	Std	Option			208V	220V	240V	380V	415V	480V
FT-20LE	12	n/a	FT-60LE	24	33	12	1	57.7	54.4	50.0	N/A	N/A	N/A
FT-25LE	12	n/a	FT-80LE	24	33			3	33.3	31.5	28.9	18.2	16.7
FT-30LE	15	18	FT-100LE	24	33	15	1	72.1	68.2	62.5	N/A	N/A	N/A
FT-40LE	24	15 & 18						3	41.6	39.4	36.1	22.8	20.9
						18	1	86.5	81.8	75	N/A	N/A	N/A
								3	50	47.2	43.3	27.3	25
						24	3	66.6	63.0	57.7	36.5	33.4	28.9
								33	3	91.6	86.6	79.4	50.1

DIMENSIONS

MODEL	A	B	C	D	E	F	G	H	J(2")*	J(3")*	K(2")*	K(3")*	L	M*
FT-20LE	21 [533]	18 [457]	38 [965]	36[914]	15 [381]	18 [457]	13.38 [340]	17.5 [445]	14.75 [375]	15.5 [394]	18 [457]	17 [432]	-	63.5 [1613]
FT-25LE	21 [533]	20.5 [523]	36.75 [933]	36 [914]	30 [762]	18 [457]	9.5 [241]	17.5 [445]	12 [305]	13.13 [333]	14.38 [365]	17.13 [435]	-	63.88 [16.22]
FT-30LE	24 [610]	20 [508]	38 [965]	39 [990]	16.5 [419]	19 [483]	12.38 [314]	19.25 [489]	16.75 [425]	17.25 [438]	16 [406]	15.5 [394]	-	66.5 [1689]
FT-40LE	26 [660]	22.5 [572]	38 [965]	41 [1041]	17.5 [445]	23 [584]	10 [254]	20.25 [489]	17.5 [445]	18.5 [470]	13.5 [343]	13 [430]	-	68.5 [1740]
FT-60LE	29.5 [749]	26 [660]	42 [1067]	44.5 [1124]	19.13 [486]	24 [610]	11 [280]	22.5 [514]	19.5 [495]	20.75 [527]	14 [356]	13.5 [343]	10.5 [267]	76 [1930]
FT-80LE	33 [838]	28 [711]	45 [1143]	48 [1219]	20.88 [530]	27 [686]	12.63 [321]	23.75 [565]	20.25 [514]	21.25 [540]	15 [381]	14.5 [368]	12 [305]	82.5 [2096]
FT-100LE	35.5 [902]	29.75 [756]	48.75 [1238]	49.5 [1257]	22.25 [565]	32 [813]	14.5 [368]	25.25 [641]	20.25 [514]	21.25 [540]	18.75 [476]	18.25 [464]	14 [356]	88.5 [2248]

* Optional

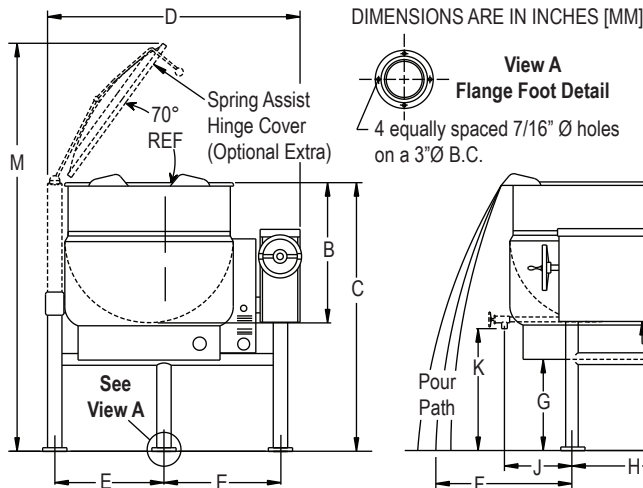

SERVICE CONNECTIONS

EC	Electrical Connection to be as specified on data plate.
HW & CW	Hot & Cold Water - 5/8" O.D. Tubing (Optional)

NOTE: 60, 80 & 100 gal. Kettles are supplied with (2) rear support legs

NOTE:
2" Valve
Closed 5.13 [130]
Open 6.88 [175]

3" Valve
Closed 7.88 [200]
Open 10.13 [257]

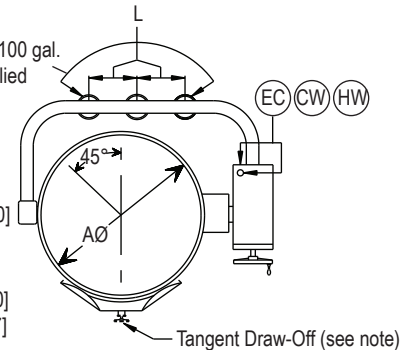

The manufacturer reserves the right to modify materials and specifications without notice.



MARKET FORGE

PRINTED IN U. S. A.
SPEC SHEET: 14-0192 Rev C (2/18)



Tel: (802) 658-6600 • Fax: (802) 864-0183 • www.marketforge.com

FOOD SERVICE EQUIPMENT
Tilting Tri or Quad Leg Kettle