



Job _____ Item No. _____

Electric Cheesemelter

□124CMW □136CMW □148CMW



124CMW

DESCRIPTION

Lang electric cheesemelters are designed to be a versatile solution for finishing. These units are great for burgers, nachos, soup, and anything else that can use some finishing heat before serving. The units are compact and thanks to weight-triggered heating, these are very energy efficient. These are designed to fit in any kitchen with wall and countertop mounting options.

SPECIFICATIONS

The Lang electric cheesemelter will be constructed in the U.S.A. with a corrosion-resistant stainless steel body and aluminized steel rear cover. The infrared quartz heating elements will be triggered by weight being placed on the plate and will turn off when food is removed. The units will use 1200 watts per foot of unit length. 148 models will have independent controls for the left and right halves. The unit is shipped as a wall-mount version. The rear panel can be removed to use as a pass-through unit and legs can be added for countertop use. 124 and 136 models will run 1-phase on 208 V or 240 V. 148 models can run 1-phase or 3-phase on 208 V or 240 V.

WARRANTY

These units come with a one [1] year warranty for parts and labor. The quartz heaters carry a ninety [90] day warranty.

FEATURES

- Infrared quartz heaters that operate at 1650°F (899°C) and heat fully in seconds meaning no pre-heating or idle needed
- Weight-sensing instant-on/off translates to energy savings
- Four [4] position adjustable chrome-plated rack
- 48-inch (1.22 m) version features independent left and right heating
- Wall-mounted or countertop versions and pass through or single-sided use meet the needs of your operation

OPTIONS & ACCESSORIES

- Heater guard [2 required for 48-inch model]
- Set of four [4] inch legs for countertop use

CERTIFICATIONS





Electric Cheesemelter

□124CMW □136CMW □148CMW

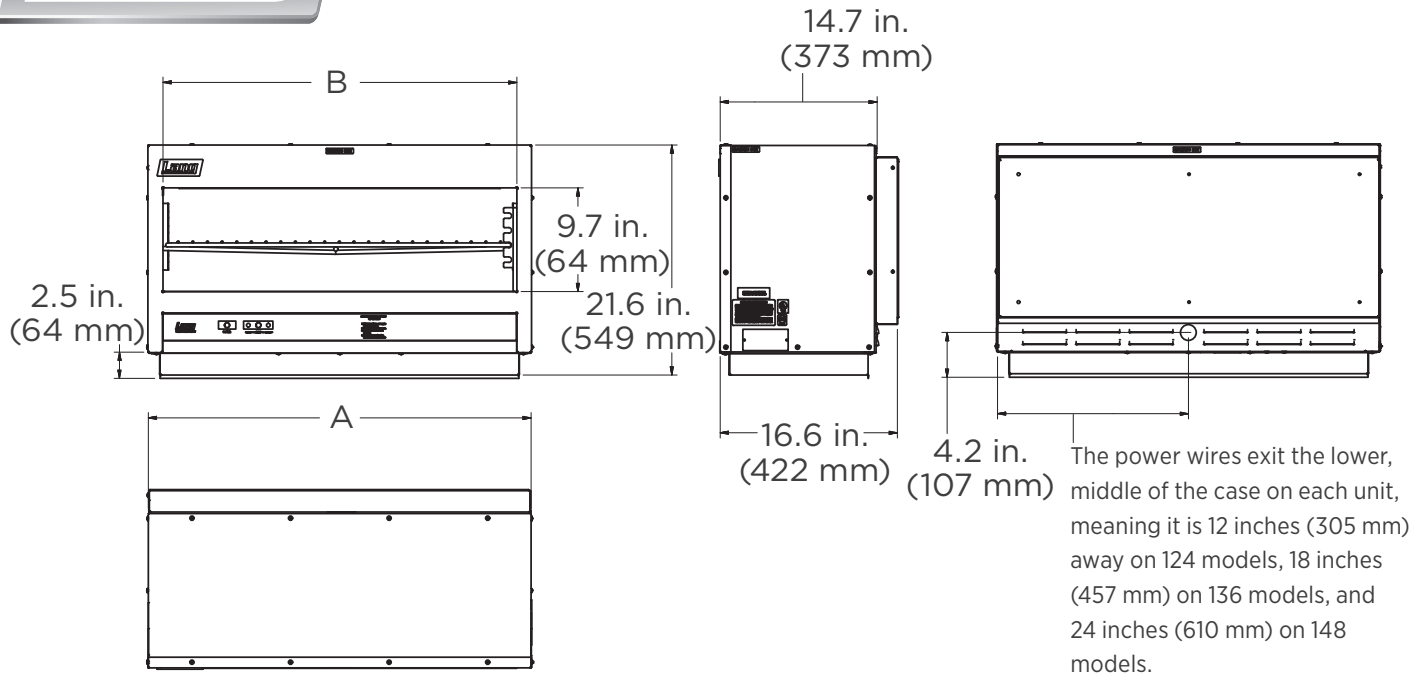

136CMW shown

CLEARANCES AND OTHER DIMENSIONS

You must keep two [2] inches (51 mm) on each side, and fifteen [15] inches (381 mm) in front [and in back if using as pass-through] between the unit and any surface. This must be mounted at least twelve [12] inches (305 mm) above any cooking surface and will require a lower heat shield to be installed in such a location. These units should not be mounted above charbroilers or other open burners due to the excess heat load on electrical components. Exercise caution when mounting in proximity to fryers, griddles, or other products which generate grease-laden vapors that can damage the cooling fan or internal components. When using the optional legs, the center of the legs will be set approximately 0.8 inches (20 mm) from the sides and 1.5 inches from the front and rear of the main case. Optional legs are four [4] inches (102 mm) tall.

MODEL	HEIGHT in. (mm)	WIDTH in. (mm) [A]	OPENING WIDTH in. (mm) [B]	DEPTH in. (mm)	kW	AMPS				APPROX. SHIP WEIGHT	APPROX. WEIGHT INSTALLED
						208 V 1Φ	240 V 1Φ	208 V 3Φ L1/L2/L3	240 V 3Φ L1/L2/L3		
124CMW	21.6 (549)	24 (610)	21 (533)	28.5 (724)	2.4	11.5	10			105 lb. (47.6 kg)	90 lb. (40.8 kg)
136CMW	21.6 (549)	36 (914)	33 (838)	28.5 (724)	3.6	17.3	15			130 lb. (59 kg)	110 lb. (49.9 kg)
148CMW	21.6 (549)	48 (1219)	45 (1143)	28.5 (724)	4.8	23.1	20	11.5/20/11.5	10/17.3/10	180 lb. (81.6 kg)	145 lb. (65.8 kg)

Due to periodic changes in designs, methods, procedures, policies and regulations, the specifications contained in this sheet are subject to change without notice. While Star Manufacturing exercises good faith efforts to provide information that is accurate, we are not responsible for errors or omissions in information provided or conclusions reached as a result of using the specifications. By using the information provided, the user assumes all risks in connection with such use.



LANG MANUFACTURING • www.langworld.com
 10 Sunnen Drive • Saint Louis, Missouri 63143
 Telephone 314 678 6315 • Fax 314 781 3636

Printed in the U.S.A. • 2M-Z21302 • Rev - • 03.2017
 Please refer to the owner's manual for information regarding installation or use.