



Item No. _____

Project _____

Quantity _____

Electric, Full-Size/Economy Convection Ovens

Models: FCOF-AT[1/2/3]

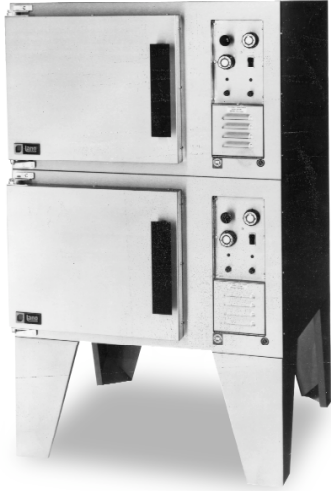

Model FCOF-AT2 shown, with optional angular legs

PAN CAPACITY GUIDE

Model/Pan Type:	18" x 26" Bake	12" x 20" x 4"
FCOF-AT1 or FCOF-AT	6	3
FCOF-AT2	12	6
FCOF-AT3	18	9

SHORT/BID SPECIFICATION

Convection Oven[s] shall be **LANG Manufacturing Model _____ FCOF-AT [Insert 1, 2 or 3]**, a 6.6-kW [each] electric heated 6-pan full-size Economy Series unit, with: space saving 36" overall width; single solid, insulated door with magnetic closure; all stainless steel exterior and aluminized steel cooking compartment; powerful side mounted blower; and three pan racks standard; plus all the features listed and options/accessories checked:

STANDARD PRODUCT WARRANTY

- One year, parts & labor

CONSTRUCTION FEATURES

- Heavy duty 430 Series stainless steel exterior, with attractive No. 4 finish
- Fully enclosed oven back
- Cooking compartment is aluminized steel and fully insulated on six sides.
- Heavy duty solid, insulated door, with simple magnetic closure
- Powerful blower centered on the side of compartment
- Chrome steel six position pan slides with three chrome plated wire racks provided

PERFORMANCE FEATURES

- Narrow 36" width reduces hood space requirements
- Stackable up to three high, for more capacity in same footprint
- Solid, insulated door saves energy, keeps kitchen cooler
- 100-450°F operating temperature range

CONTROL PACKAGE

- Simple knob-set time and temperature controls
- 60 minute timer
- Manual vent rod
- Power-ON switch & indicator light



Sheet No. LSP-C11 (rev. 06/07)

LANG MANUFACTURING - A DIVISION OF STAR MANUFACTURING INT'L, INC. • 10 SUNNEN DR. ST. LOUIS, MO 63143
TOLL FREE: 800.264-7827 • FAX: 314-781-3636 • www.langworld.com

INSTALLATION REQUIREMENTS

- $\text{\textcircled{E}}$ 208V or 240V 1- or 3-Phase power required, or 480V, 3-Phase as option
- Installation under approved vent hood may be required. Consult local codes. [Power connection[s] from bottom. See below]

OPTIONS & ACCESSORIES

- 480 Volt, 3-phase model, per oven deck
- 27" stainless steel angular legs for FCOF-AT1 Model
- 16" stainless steel angular legs for FCOF-AT2 Model
- 6" stainless steel angular legs for FCOF-AT3 Model
- Stainless steel oven liner, per oven deck
- Extra wire pan racks [3 provided as std., per oven deck]

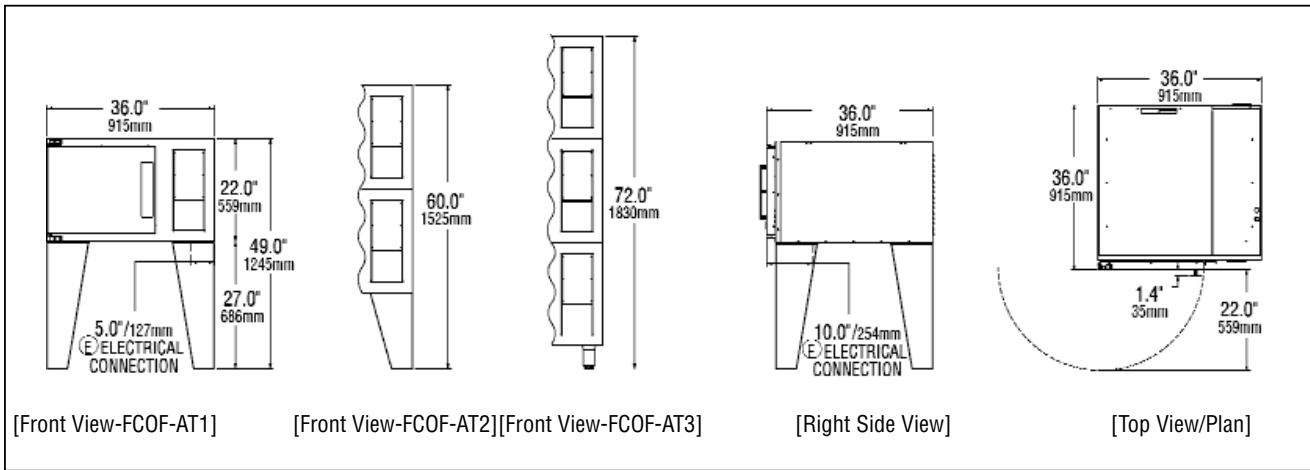

Model	Height x Width x Depth (without legs)	Clearance from combustible surface	Weight		Freight Class
			Actual	Shipping	
FCOF-AT	22.0" x 36.0" x 36.0" 559mm x 915mm x 915mm	Sides: 6" (153mm) Back: 6" (153mm) Floor: 6" (153mm)	235 lbs. 107 kg	275 lbs. 125 kg	85
FCOF-AT1	22.0" x 36.0" x 36.0" 559mm x 915mm x 915mm		260 lbs. 118 kg	300 lbs. 136 kg	85
FCOF-AT2	44.0" x 36.0" x 36.0" 1118mm x 915mm x 915mm		445 lbs. 202 kg	525 lbs. 239 kg	85
FCOF-AT3	66.0" x 36.0" x 36.0" 1676mm x 915mm x 915mm		640 lbs. 291 kg	760 lbs. 345 kg	85

Voltage	$\text{\textcircled{E}}$ Electrical Requirements By Model						
	Phase	Model FCOF-AT & FCOF-AT1		Model FCOF-AT2		Model FCOF-AT3	
		Total kW	Amps/Line	Total kW	Amps/Line	Total kW	Amps/Line
208V/60Hz	1	6.6	31.7	13.2	63.5	19.8	95.2
240V/60Hz	1	6.6	27.5	13.2	55.0	19.8	82.5
208V/60Hz	3	n/a	n/a	13.2	55.0	19.8	55.0
240V/60Hz	3	n/a	n/a	13.2	47.6	19.8	47.6
480V/60Hz	3	6.6	13.8	13.2	23.8	19.8	23.8

CAD SYMBOLS & PRICING



Due to continuous improvements, specifications subject to change without notice.



Sheet No. LSP-C11 (rev. 06/07)

LANG MANUFACTURING - A DIVISION OF STAR MANUFACTURING INT'L, INC. • 10 SUNNEN DR. ST. LOUIS, MO 63143
TOLL FREE: 800.264-7827 • FAX: 314-781-3636 • www.langworld.com