



Lang
Wave

Item No. _____

Project _____

Quantity _____

30" Electric Induction Top Range with Convection Oven Base

Model: RI30C Series



Model RI30C-PTA Shown

SHORT/BID SPECIFICATION

Range shall be a **LANG Manufacturing Model RI30** ____ [Specify one]:

_APA: Accu-Plus Control

_PTA: Platinum Control

A 30" wide heavy duty electric heated unit with five half size pan capacity convection oven base and 18.2 kW total power input; all stainless steel exterior; fully insulated oven with stainless steel interior, heavy duty door hinged left, with double pane viewing window and five chrome plated oven rack standard; with individual cook-top component controls; 4 ea. 8" diameter induction burner.

STANDARD PRODUCT WARRANTY

- Two year, parts & labor
- Lifetime warranty on oven door mechanism

CONSTRUCTION FEATURES

- 6mm glass induction top thickness for added durability
- One piece heavy duty 430 Series stainless steel exterior, with attractive No. 4 finish
- Cooking compartment is 430 Series stainless steel
- 2" insulation on six sides of cooking compartment
- Heavy duty compartment door, with large double pane tempered glass window
- Powerful blower centered on side of compartment
- Nine position oven rack slide supports
- Five chrome-plated oven racks provided
- 4" swivel casters standard
- 2-3/4" wide full width front grease trough
- Grease drain in trough with full width & depth spillage drawers

PERFORMANCE FEATURES

- Compact 30" wide range incorporates half-size convection oven with five 13 X 18" pan capacity
- No flames or hot coils contribute to safer, cleaner cooking
- Induction cooking results in a cooler kitchen
- Controlled heating allows for precise, consistent cooking
- 150° to 450° F oven operating temperature range
- Solid state oven temperature control accurate to 4° F
- Two speed fan with fan pulse capability
- Door interlock switch cuts power to fan
- Choice of cook top configurations, to include:
 - 4 ea. 8" diameter induction burner

CONTROLS [For Oven] CHOICE OF:

- **Accu-Plus™ Control [-APA]**
 - Simple knob-set time and temperature controls
 - 1-hour timer with non-stop buzzer
 - Pulse-fan switch
 - HIGH-LOW speed fan switch
 - Power-ON switch
- **Platinum Control [-PTA]**
 - Solid state, icon driven, one-touch programmable controls
 - Up to 99 product programs, with multiple baking tiers
 - Time, temperature, heat loss and adjustable shelf compensation
 - Cook-n-Hold programming
 - 2-speed fan & variable-rate pulse-fan control



Sheet No. LSP-ID1 (rev. 02/12)

30" Electric Induction Top Range with Convection Oven Base

Model: RI30 Series

INSTALLATION REQUIREMENTS

- Unit is shipped in one piece
- (E) Single 208/240V, 1/ 3-Phase
- Installation under approved vent hood required. Consult local codes. [Power connection from bottom. See below]

OPTIONS & ACCESSORIES

- Extra wire pan rack [Five provided as std.]

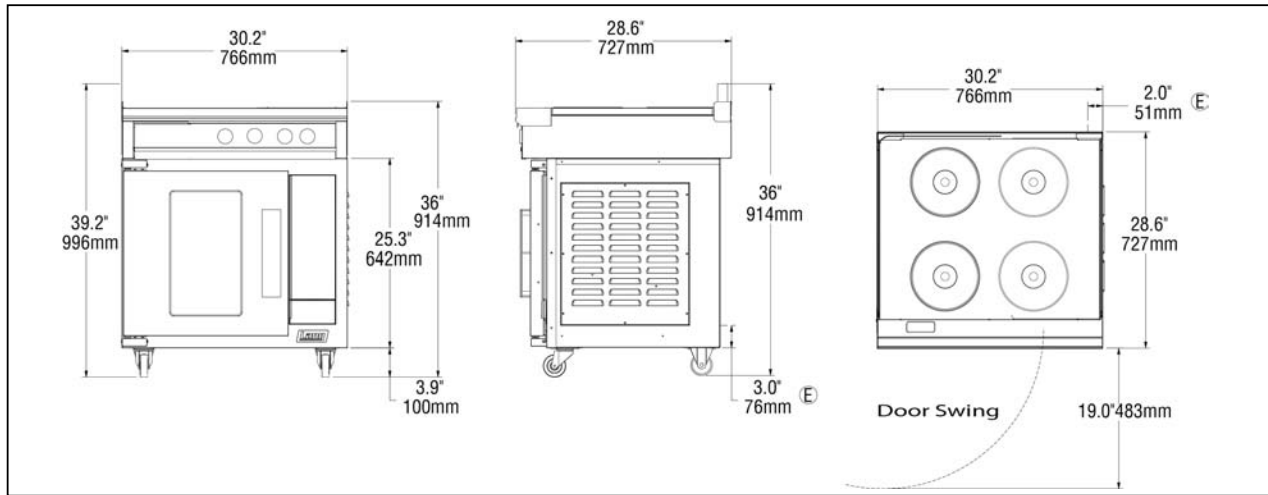

[Front View/Elevation]

[Right Side View]

[Top View/Plan]

Model	Height x Width x Depth (With standard 4" casters)	Clearance from combustible surface	Weight		Freight Class
			Actual	Shipping	
RI30_	36" x 30.2" x 30" 914mm x 766mm x 762mm	Sides: 3" Back: 3"	362* lbs. 165 kg	412* lbs. 187 kg	85

Model	(E) Electrical Requirements			
	Voltage	Total kW	Phase	Amps/Line
RI30_	208V/60Hz	18.2	1/3	87.5/54
	240V/60Hz	18.2	1/3	75.8/47

CAD SYMBOLS & PRICING



Due to continuous improvements, specifications subject to change without notice.



LANG MANUFACTURING • 10 SUNNEN DR. ST. LOUIS, MO 63143
PHONE: 314-678-6315 • FAX: 314-781-3636 • www.langworld.com