



NOR-LAKE, INCORPORATED
727 Second Street
Hudson, Wisconsin 54016

800-955-5253
715-386-2323
866-961-5253 Parts
800-388-5253 Service
715-386-6149 FAX
www.norlake.com

ADVANTEDGE™ PIZZA PREP TABLE

PIZZA PREP TABLE

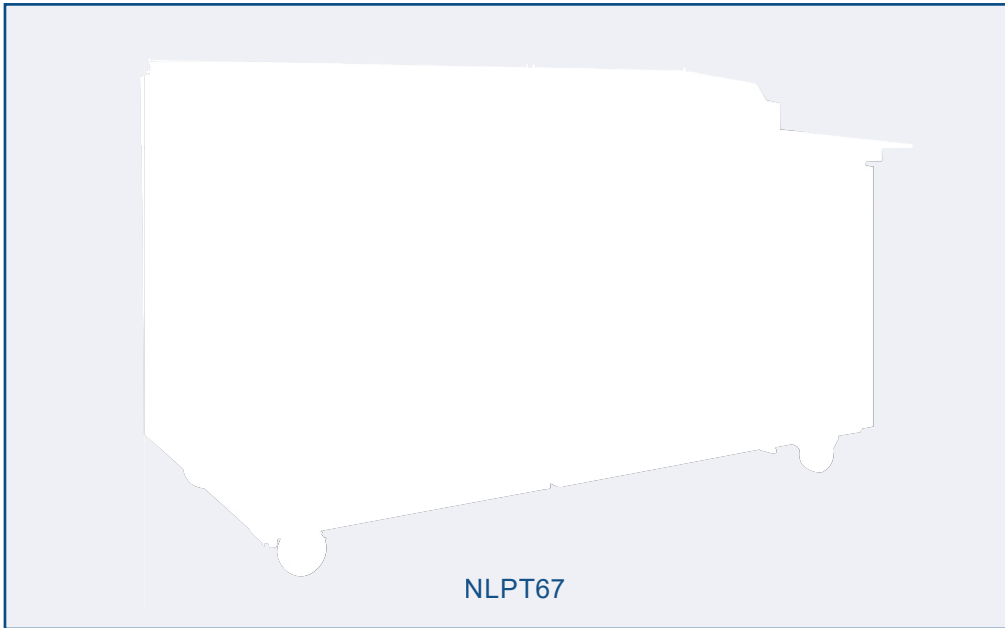

PROJECT:
.....
ITEM NUMBER:
.....
MODEL NUMBER:
.....

SPECIFICATIONS FOR: NLPT44, NLPT67, NLPT93

- **Finish:** Stainless steel interior and exterior. Aluminum back and galvanized bottom.
- **Insulation:** The complete cabinet and doors are foamed-in-place with polyurethane insulation. Insulated covers on rail.
- **Hardware:** Curved handle with recessed pocket, two vinyl coated shelves per door adjustable in 1/2" increments, 6" casters, self-closing doors, 19" reversible cutting board, 1/3 size pans.
- **Electrical:** 115 volt, 60 Hz, 1 phase with cord and NEMA 5-15P plug.
- **Refrigeration:** Self-contained forced air R-134a capillary tube refrigeration system for NLPT44 and NLPT67, R-404a for NLPT93. Automatic defrost and condensate evaporator requires no plumbing. Adjustable temperature control. Temperature range: +34°F to +38°F for storage area, +33°F to +41°F for refrigerated rail.
- **Approvals:** UL, C-UL and ETL Sanitation listed **

STANDARD FEATURES

- Air cooled condensing unit
- Automatic condensate vaporizer
- Automatic defrost
- Capillary tube system
- Interior temperature indicator
- Adjustable temperature control
- Insulated rail covers with hold open hinges
- Self closing doors with magnetic gasket
- Stainless steel interior
- Stainless steel exterior (aluminum back, galvanized bottom)
- 1/3 size pans provided
- 6" casters
- 19" reversible cutting board
- UL, C-UL and ETL Sanitation listed **
- Warranties: 3 year parts & labor, 5 year compressor

OPTIONAL FEATURES*

- Additional shelves
- Refrigerated pull-out drawers
- Single or double overshelf

* Most options are available one week from receipt of order. Please contact us for specific questions.

** C-UL is Underwriters Laboratories Safety Certification Mark which indicates that UL has tested the equipment to applicable CSA Standards.

** UL-Sanitation is Underwriters Laboratories Safety Certification Mark which indicates that UL has tested the equipment to applicable NSF Standards.

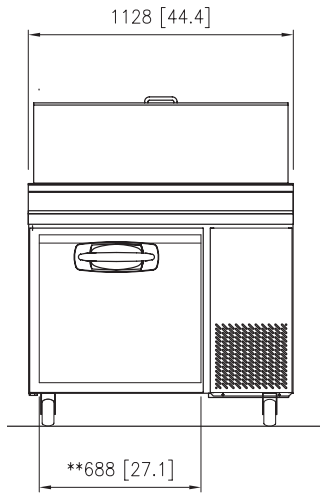

**NLPT44
FRONT**

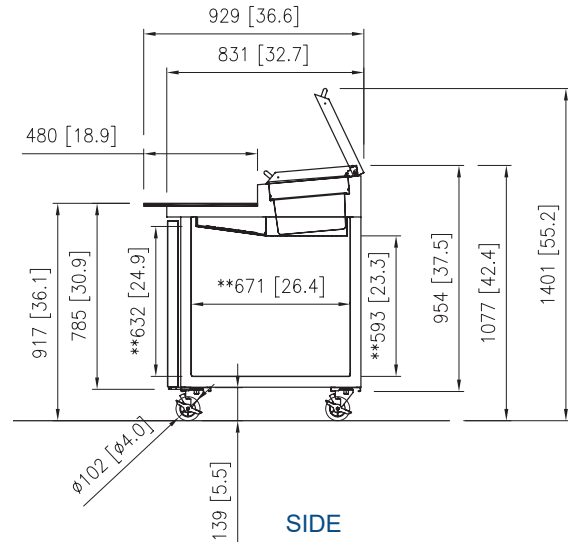

SIDE

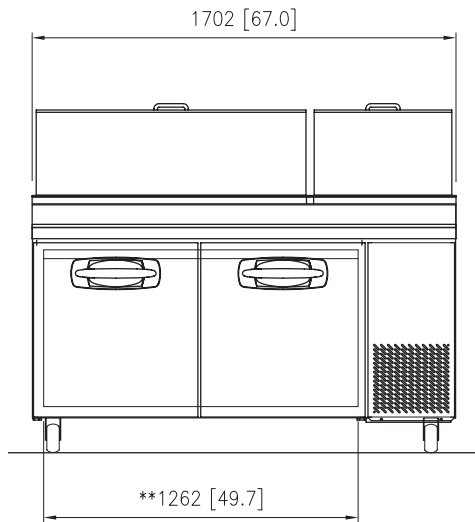

**NLPT67
FRONT**

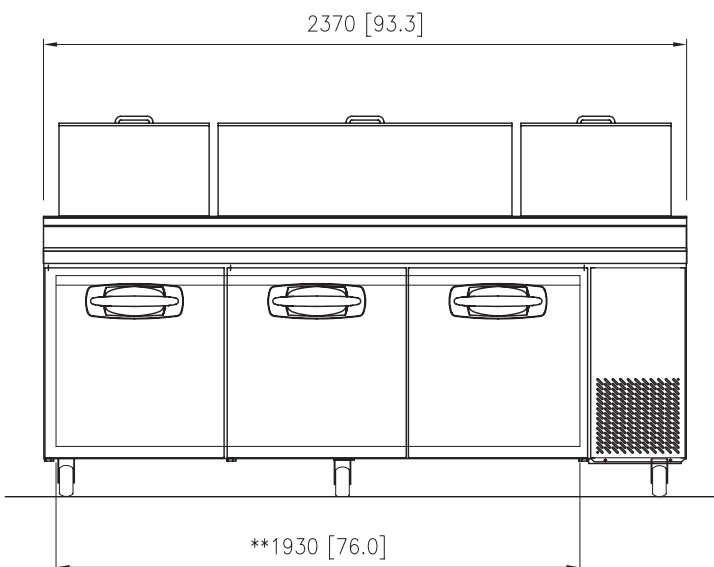

**NLPT93
FRONT**

SPECIFICATIONS

Models	NLPT44	NLPT67	NLPT93
<i>Crated Weight (lbs) (kg)</i>	309 (139)	548 (247)	698 (314)
<i>Crated Height (in) (cm)</i>	43.7 (109)	43.7 (109)	43.7 (109)
<i>Crated Width (in) (cm)</i>	48.6 (122)	71.2 (178)	97.5 (244)
<i>Crated Depth (in) (cm)</i>	36.8 (92)	36.8 (92)	36.8 (92)
<i>Interior Height (in) (cm)</i>	23.3 (58)	23.3 (58)	23.3 (58)
<i>Interior Width (in) (cm)</i>	27.1 (68)	49.7 (124)	76 (190)
<i>Interior Depth (in) (cm)</i>	26.4 (66)	26.4 (66)	26.4 (66)
<i>Overall Height (in) (cm)</i>	42.4 (106)	42.4 (106)	42.4 (106)
<i>Overall Width (in) (cm)</i>	44.4 (111)	67 (168)	93.3 (233)
<i>Overall Depth (in) (cm)</i>	36.6 (92)	36.6 (92)	36.6 (92)
<i>Gross Cubage (CuFt) (L)</i>	9.7 (275)	17.8 (504)	27.2 (770)
<i>Number of 1/3 Pans</i>	6	9	12
<i>Number of Shelves</i>	2	4	6
<i>Shelf Area (SqFt) (Sqm)</i>	14.1 (1.31)	25.8 (2.40)	39.9 (3.71)
<i>Number of Casters</i>	4	4	6
<i>Condensing Unit Size</i>	3/8 HP	3/8 HP	1/2 HP
<i>Refrigerant</i>	R-134a	R-134a	R-404a
<i>Electrical Characteristics</i>	115/60/1	115/60/1	115/60/1
<i>Cord and Plug Furnished</i>	Yes	Yes	Yes
<i>NEMA Plug Configuration</i>	5-15P	5-15P	5-15P
<i>Total Amp Draw</i>	6.5	6.5	7.5

Specifications subject to change without notice.



Revision Date: 4/18
Part Number: 143462