

## ADVANTEDGE™ UNDERCOUNTER / WORKTABLE FREEZERS



PROJECT:

ITEM NUMBER:

MODEL NUMBER:

UNDERCOUNTER / WORKTABLE FREEZERS

### SPECIFICATIONS FOR: NLUF27A, NLUF48A, NLUF60A

- Finish: Stainless steel interior and exterior
- Insulation: Complete cabinet and doors are foamed-in-place with polyurethane insulation
- Hardware: Curved handle with recessed pocket; one vinyl coated shelf per door; 6" overall height casters; front-breathing design allows for zero-clearance installation on sides, back and top
- Electrical: 115 volt, 60 Hz, 1 phase with cord and plug
- Refrigeration: Self-contained forced air refrigeration system. Condensate is collected and automatically evaporated from an energy efficient vaporizer. Refrigerant flow controlled by a capillary tube. R-404a refrigerant. Temperature range: -5°F to 0°F
- Approvals: UL, C-UL Safety and UL Sanitation listed \*\*, ADA compliant \*\*\*

### STANDARD FEATURES

- Air cooled condensing unit
- Automatic condensate vaporizer
- Automatic defrost
- Capillary tube system
- Casters
- Curved handle with recessed pocket
- Magnetic gaskets
- Self-closing doors
- Stainless steel interior and exterior
- Vinyl coated shelves
- UL, C-UL Safety and UL Sanitation listed \*\*
- Warranties: 3 year parts & labor, 5 year compressor

### OPTIONAL FEATURES\*

- Additional shelves
- Stainless steel backsplash
- Low profile casters \*\*\*
- Single and double oversshelf assemblies
- Stacking kit, 27" model only
- 4" Base kit
- 6" Legs
- Door locks

\* Most options are available two weeks from receipt of order. Please contact us for specific questions.

\*\* C-UL is Underwriters Laboratories Safety Certification Mark which indicates that UL has tested the equipment to applicable CSA Standards.

\*\*\* UL Sanitation is Underwriters Laboratories Sanitation Mark which indicates that UL has tested the equipment to applicable NSF Standards..

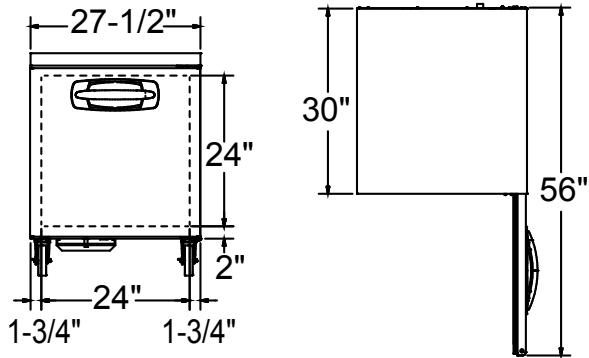

NLUF27A  
FRONT VIEW TOP VIEW

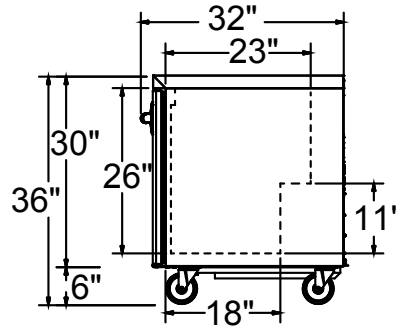

ALL MODELS  
SIDE VIEW

**SPECIFICATIONS**

Models	NLUF27A	NLUF48A	NLUF60A
Crated Weight (lbs) (kg)	195 (89)	265 (120)	320 (145)
Crated Height (in) (cm)	36-1/4 (92)	36-1/4 (92)	36-1/4 (92)
Crated Width (in) (cm)	30-1/8 (75)	51-1/8 (130)	63 (160)
Crated Depth (in) (cm)	33-1/2 (85)	33-1/2 (85)	33-1/2 (85)
Interior Height (in) (cm)	26-1/8 (66)	26-1/8 (66)	26-1/8 (66)
Interior Width (in) (cm)	24 (61)	44 (112)	56 (142)
Interior Depth (in) (cm)	23 (58)	23 (58)	23 (58)
Overall Height (in) (cm)	36 (91)	36 (91)	36 (91)
Overall Width (in) (cm)	27-1/2 (70)	48 (122)	60 (152)
Overall Depth (in) (cm)	30 (76)	30 (76)	30 (76)
Gross Cubage (CuFt) (L)	7.2 (203)	13.4 (379)	16.2 (458)
Number of Shelves	1	2	2
Shelf Area (SqFt) (Sqm)	2.75 (0.26)	5.30 (0.49)	7.32 (0.68)
Number of Casters	4	4	4
Condensing Unit Size	1/3 HP	1/2 HP	1/2 HP
Refrigerant	R-404a	R-404a	R-404a
Electrical Characteristics	115/60/1	115/60/1	115/60/1
Cord and Plug Furnished	Yes	Yes	Yes
NEMA Plug Configuration	5-15P	5-15P	5-15P
Total Amp Draw	5.2	7.5	7.5

Specifications subject to change without notice.

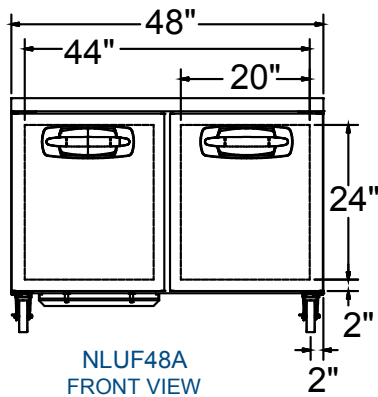

NLUF48A  
FRONT VIEW

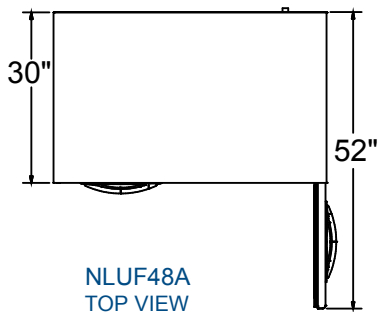

NLUF48A  
TOP VIEW

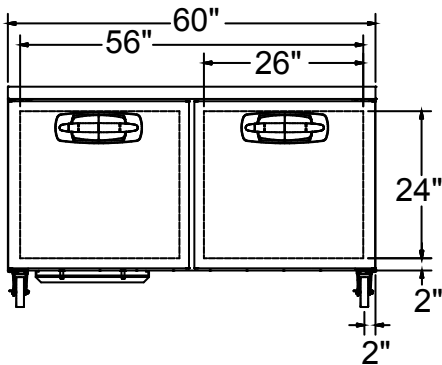

NLUF60A  
FRONT VIEW

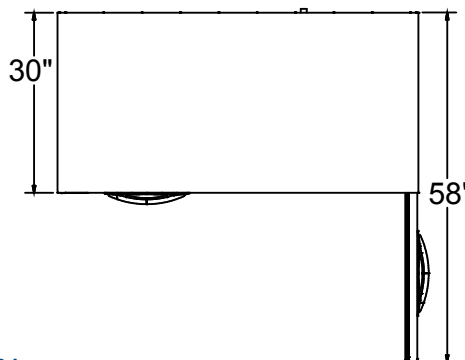

TOP VIEW



Revision Date: 03/17  
©2016 Nor-Lake, Inc.  
Printed in the USA  
Part Number: 146623