

**CANTILEVER
STYLE,
MOBILE
ADJUSTABLE**

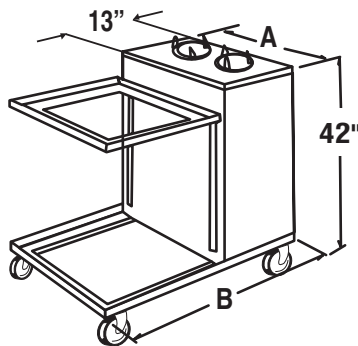

RACK SIZE	A	B
10 x 20	21	26
14 x 20	21	30
20 x 20	21	36

HEIGHT 42"-Other heights available. Dish guides add 4" to height.
Shipping weight-200

JOB _____ ITEM # _____ QTY # _____

MODEL NUMBER

ACSCA-ST

CAPACITY

Up to 175 cups (in racks) and approx. 100 to 144 saucers.

SPECIFICATIONS

Model ACSCA-ST mobile cup and saucer dispenser.

FRAME AND BODY:

The frame is constructed of all welded heavy gauge stainless steel. The body is 20 ga. stainless steel on all sides and top, and is fitted with a stainless steel tubular push handle. The front panel is removable for adjustment access.

CUP DISPENSING MECHANISM:

The rack carrier, constructed of all welded 16 ga. stainless steel, is raised by a series of coil springs attached to the frame. Ball bearing guides and a single stainless steel aircraft type cable keep the carrier level in all directions, even with an unbalanced load. The cable runs over pre-lubricated plated steel pulleys. Adjustment for varying weights is easily accomplished by removing the front panel, then engaging or disengaging individual springs as required.

SAUCER DISPENSERS:

The unit includes two Model AT adjustable, drop-in saucer dispensers (see Page D-9 for specifications). The saucer diameter (6-1/2" maximum) is required when ordering.

CASTERS:

The unit is mounted on four 4" diameter, heavy duty, double ball bearing casters.

OPTIONS

- WB - Two (2) Locking Casters
- PB - Perimeter Bumper
- Y4 - Polyurethane 4" casters, set of 4, with ball bearing seals
- Y5 - Polyurethane 5" casters, set of 4, with ball bearing seals

LIMITED WARRANTY: PIPER PRODUCTS warrants to the original purchaser parts and labor for a period of twelve (12) months from the date of purchase. See manufacturer's complete warranty for details.

It is our policy to build equipment which is design certified by companies that have been accredited at the Federal Level by the Occupational Safety and Health Agency (OSHA) and ANSI as a National Recognized Testing Laboratory. These companies include CSA International, Underwriters Laboratories, and the National Sanitation Foundation. However, a continuing program of product improvement makes it necessary to submit new models to the agencies as they are developed. Consequently, all models may not bear the appropriate labels at all times.

We reserve the right to change specifications and product design without notice. Such revisions do not entitle buyer to corresponding changes, improvements, additions or replacements for previously purchased equipment. Information is not for design purposes.

SPEC E-16

PIPER PRODUCTS
BUILT TO LAST
www.piperonline.net

300 S. 84th Avenue
Wausau, WI 54401
Phone: 800-544-3057
Fax: 715-842-3125