



ITEM #: \_\_\_\_\_ QTY: \_\_\_\_\_  
 MODEL #: \_\_\_\_\_  
 PROJECT NAME: \_\_\_\_\_

3601 S. Banker St. Effingham, IL 62401 • P.O. BOX 609 • Ph: (888) 431-2667 • Fax: (800) 433-2667

**“ST4-GBK” STAINLESS STEEL TOP WORK TABLES**  
**14GA TOP AND GALV LEGS AND ADJUSTABLE BRACING**



**FEATURES:**

- 14 GAUGE STAINLESS STEEL TOP
- TYPE 300 STAINLESS STEEL WITH # 4 POLISH, SATIN FINISH
- TOP IS SOUND DEADENED
- REINFORCED WITH 1"X2" CHANNEL RUNNING ENTIRE LENGTH OF TABLE
- 1-1/2" STALLION EDGE ON FRONT AND REAR WITH SIDE EDGES 90 DEGREE BEND DOWN FOR TABLE LINE-UP
- GALVANIZED BASE WITH ADJUSTABLE BRACING
- SHIPPED KNOCKED-DOWN, EASY - TO - ASSEMBLE
- NSF CERTIFIED



ST4-3048GBK

**CONSTRUCTION:**

- TOP: STAINLESS STEEL TOPS ARE TIG WELDED, EXPOSED WELDS ARE POLISHED TO MATCH ADJACENT SURFACE.

**MATERIAL:**

- TOP: 14 GAUGE STAINLESS STEEL TYPE 300 STAINLESS STEEL WITH # 4 POLISH, SATIN FINISH
- BRACING: 1-1/4" ROUND O.D. 18 GAUGE GALVANIZED STEEL
- LEGS: 1-5/8" ROUND O.D., 16 GAUGE TUBULAR GALVANIZED STEEL
- GUSSETS: GALVANIZED STEEL
- FEET: 1" GALVANIZED BULLET FEET



ADJUSTABLE BRACING

**14 GAUGE TOP W/ ADJUSTABLE BRACING**

24" WIDE	QTY	30" WIDE	QTY	36" WIDE	QTY
ST4-2436GBK		ST4-3036GBK		ST4-3636GBK	
ST4-2448GBK		ST4-3048GBK		ST4-3648GBK	
ST4-2460GBK		ST4-3060GBK		ST4-3660GBK	
ST4-2472GBK		ST4-3072GBK		ST4-3672GBK	
ST4-2484GBK		ST4-3084GBK		ST4-3684GBK	
ST4-2496GBK		ST4-3096GBK		ST4-3696GBK	
ST4-24108GBK		ST4-30108GBK		ST4-36108GBK	
ST4-24120GBK		ST4-30120GBK		ST4-36120GBK	

**OPTIONAL ACCESSORIES**

DESCRIPTION	MODEL #	QTY
DRAWER		
DRAWER LOCK		
CASTERS		
OVERSHELVES		
SINKS		
POT RACK		

## DETAILED SPECIFICATIONS

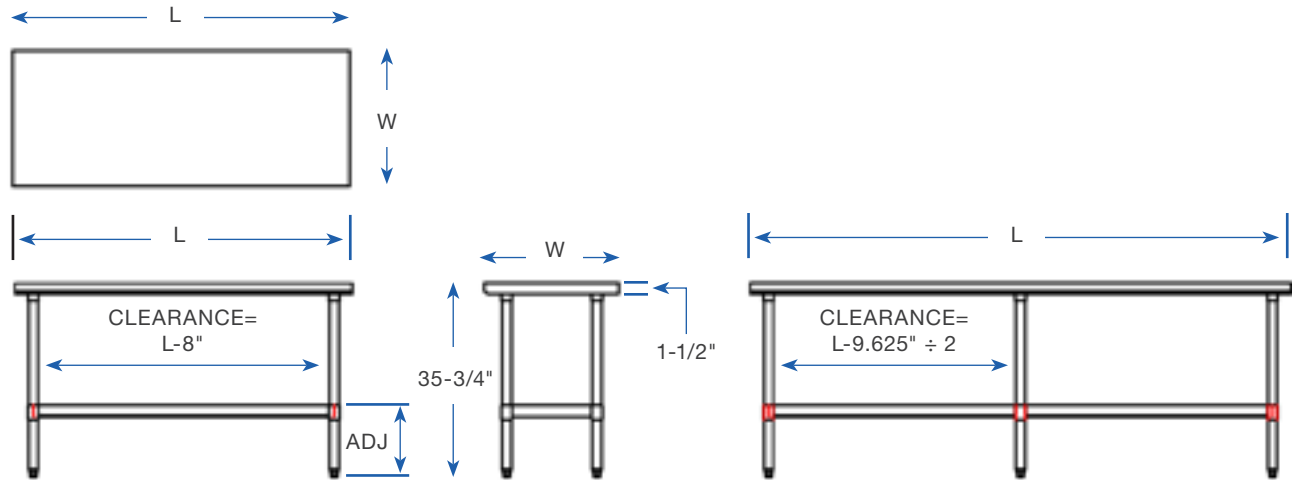

- UNITS 7 FT. AND LARGER ARE FURNISHED WITH SIX LEGS.

### 14 GAUGE TOP W/ ADJUSTABLE BRACING

LENGTH	24" WIDE	WT. (LBS)	30" WIDE	WT. (LBS)	36" WIDE	WT. (LBS)
36"	ST4-2436GBK	50	ST4-3036GBK	55	ST4-3636GBK	70
48"	ST4-2448GBK	60	ST4-3048GBK	67	ST4-3648GBK	75
60"	ST4-2460GBK	70	ST4-3060GBK	79	ST4-3660GBK	88
72"	ST4-2472GBK	80	ST4-3072GBK	91	ST4-3672GBK	101
84"	ST4-2484GBK	95	ST4-3084GBK	107	ST4-3684GBK	119
96"	ST4-2496GBK	109	ST4-3096GBK	122	ST4-3696GBK	136
108"	ST4-24108GBK	119	ST4-30108GBK	134	ST4-36108GBK	150
120"	ST4-24120GBK	129	ST4-30120GBK	146	ST4-36120GBK	163

### MODEL # STRUCTURE

30 = WIDTH OF WORK SURFACE      120 = LENGTH OF WORK SURFACE  
 4 = 14GA WORK SURFACE            GB = GALVANIZED LEGS & BRACING  
 ST = STAINLESS STEEL TOP        K = K.D. W/ ADJUSTABLE BRACING

## ST4-30120GBK

SOME UNITS SHIP UNASSEMBLED FOR REDUCED SHIPPING COST. ALL DIMENSIONS ARE TYPICAL. TOLERANCE +/- .500"  
 John Boos & Co. is constantly engaged in a program of improving products and therefore reserves the right to change specifications without prior notice.