



ITEM #: _____ QTY: _____
 MODEL #: _____
 PROJECT NAME: _____

3601 S. Banker St. Effingham, IL 62401 • P.O. BOX 609 • Ph: (888) 431-2667 • Fax: (800) 433-2667

“ST6-GBK” STAINLESS STEEL TOP WORK TABLES
16GA TOP AND GALV LEGS AND ADJUSTABLE BRACING



FEATURES:

- 16 GAUGE STAINLESS STEEL TOP
- TYPE 300 STAINLESS STEEL WITH # 4 POLISH, SATIN FINISH
- TOP IS SOUND DEADENED
- REINFORCED WITH 1”X2” CHANNEL RUNNING ENTIRE LENGTH OF TABLE
- 1-1/2” STALLION EDGE ON FRONT AND REAR WITH SIDE EDGES
90 DEGREE BEND DOWN FOR TABLE LINE-UP
- GALVANIZED BASE WITH ADJUSTABLE BRACING
- SHIPPED KNOCKED-DOWN, EASY - TO - ASSEMBLE
- NSF CERTIFIED



ST6-3048GBK

CONSTRUCTION:

- TOP: STAINLESS STEEL TOPS ARE TIG WELDED, EXPOSED WELDS ARE POLISHED TO MATCH ADJACENT SURFACE.

MATERIAL:

- TOP: 16 GAUGE STAINLESS STEEL TYPE 300 STAINLESS STEEL WITH # 4 POLISH, SATIN FINISH
- BRACING: 1-1/4” ROUND O.D. 18 GAUGE GALVANIZED STEEL
- LEGS: 1-5/8” ROUND O.D., 16 GAUGE TUBULAR GALVANIZED STEEL
- GUSSETS: GALVANIZED STEEL
- FEET: 1” GALVANIZED BULLET FEET



ADJUSTABLE BRACING

16 GAUGE TOP W/ ADJUSTABLE BRACING

24” WIDE	QTY	30” WIDE	QTY	36” WIDE	QTY
ST6-2436GBK		ST6-3036GBK		ST6-3636GBK	
ST6-2448GBK		ST6-3048GBK		ST6-3648GBK	
ST6-2460GBK		ST6-3060GBK		ST6-3660GBK	
ST6-2472GBK		ST6-3072GBK		ST6-3672GBK	
ST6-2484GBK		ST6-3084GBK		ST6-3684GBK	
ST6-2496GBK		ST6-3096GBK		ST6-3696GBK	
ST6-24108GBK		ST6-30108GBK		ST6-36108GBK	
ST6-24120GBK		ST6-30120GBK		ST6-36120GBK	

OPTIONAL ACCESSORIES

DESCRIPTION	MODEL #	QTY
DRAWER		
DRAWER LOCK		
CASTERS		
OVERSHELVES		
SINKS		
POT RACK		

DETAILED SPECIFICATIONS

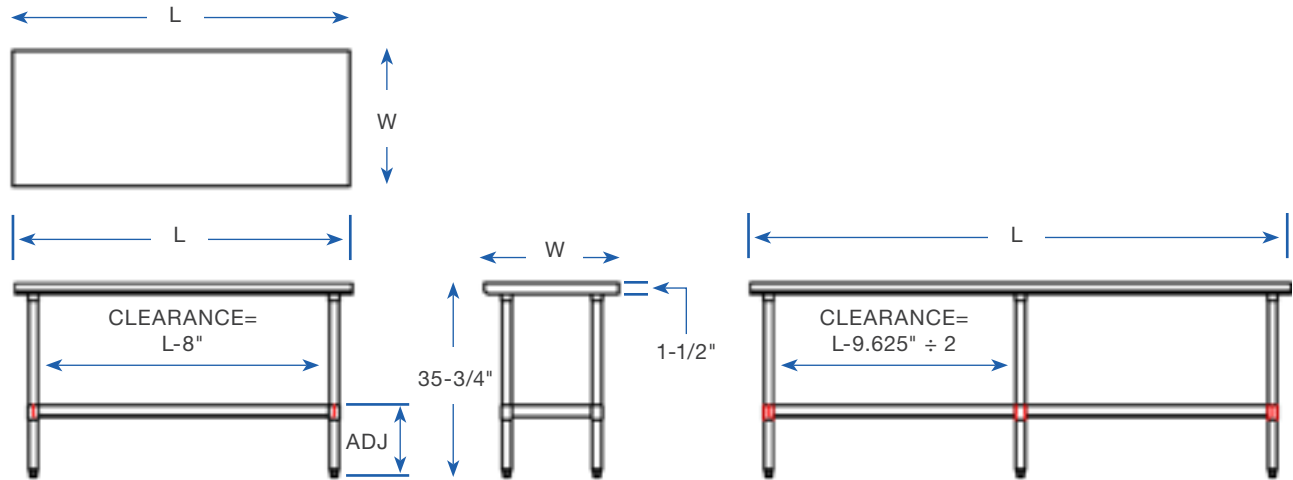

- UNITS 7 FT. AND LARGER ARE FURNISHED WITH SIX LEGS.

16 GAUGE TOP W/ ADJUSTABLE BRACING

LENGTH	24" WIDE	WT. (LBS)	30" WIDE	WT. (LBS)	36" WIDE	WT. (LBS)
36"	ST6-2436GBK	50	ST6-3036GBK	55	ST6-3636GBK	70
48"	ST6-2448GBK	60	ST6-3048GBK	67	ST6-3648GBK	75
60"	ST6-2460GBK	70	ST6-3060GBK	79	ST6-3660GBK	88
72"	ST6-2472GBK	80	ST6-3072GBK	91	ST6-3672GBK	101
84"	ST6-2484GBK	95	ST6-3084GBK	107	ST6-3684GBK	119
96"	ST6-2496GBK	109	ST6-3096GBK	122	ST6-3696GBK	136
108"	ST6-24108GBK	119	ST6-30108GBK	134	ST6-36108GBK	150
120"	ST6-24120GBK	129	ST6-30120GBK	146	ST6-36120GBK	163

MODEL # STRUCTURE

30 = WIDTH OF WORK SURFACE
 6 = 16GA WORK SURFACE
 ST = STAINLESS STEEL TOP
 120 = LENGTH OF WORK SURFACE
 GB = GALVANIZED LEGS & BRACING
 K = K.D. W/ ADJUSTABLE BRACING

ST6-30120GBK

SOME UNITS SHIP UNASSEMBLED FOR REDUCED SHIPPING COST. ALL DIMENSIONS ARE TYPICAL. TOLERANCE +/- .500"
 John Boos & Co. is constantly engaged in a program of improving products and therefore reserves the right to change specifications without prior notice.