



**F-556**

Wells F-556 Built-in Fryer is one of the most durable and versatile fryers in the industry. A swing-up element allows the fry pot to be easily removed for cleaning. The low watt density provides for extended oil life. Fry two separate loads at the same time using individual half-size fry baskets.

### Features

- Swing-up element, located below the baskets, allows easy removal of the fry pot for cleaning. Element is heavy-duty stainless steel with low watt density for longer oil life.
- Element control housing has a spring-loaded support rod to secure element when in a raised position.
- A positive-off thermostat controls the element allowing for adjustable and more consistent temperatures. A signal light indicates when the heating element is energized.
- Deep-drawn, removable fry pot is made of nickel-plated steel and is designed to hold fifteen pounds of oil.
- A manual reset safety thermostat will shut off the heating element power and illuminate the signal light if an over-temperature condition is reached.
- A terminal block is provided for connection to the main power supply.
- Two half-size, rear-hanging, interchangeable fry baskets are provided and allow for product versatility.
- Wellslok allows for quick and easy installation in stainless steel countertops.

- The F-556 Fryer is Underwriters Laboratories, Inc. recognized and meets NSF International standards.
- A one-year warranty against defects covers parts and labor.

### Specifications

<b>Overall Dimensions:</b>	Inches	MM
Width	14 3/4	375
Depth	23 1/2	597
<b>Oil Capacity:</b>	Lbs.	KG
F-556	15	7
<b>Temperature Range:</b>	F°	C°
F-556	275° - 375°	135° - 190°
<b>Pre-Heat Time 350 F°:</b>	4 1/2 min.	
<b>Watts Per Hour to Maintain 350 F°:</b>	450	
<b>Typical Production:</b>	Per Hour	
French Fries (2 oz. servings)	300	
Chicken (pounds)	20	
<b>Weights:</b>	Lbs	KG
Installed	32	17
Shipping	39	18

### Accessories/Options

Basket, half-size (2 per fry pot), 20161  
 Basket, full-size (1 per fry pot), 20162  
 Crumb Cradle, 20690  
 Fry Pot, replacement, 20169  
 Fry Pot Cover, 21010



DIMENSIONS: INCH  
(MM)

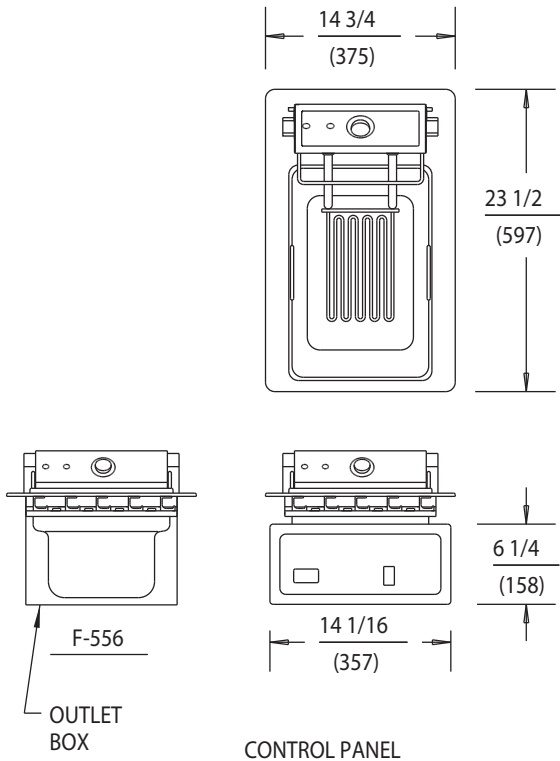

MINIMUM CLEARANCE REQUIRED FROM UNIT TO THE NEAREST COMBUSTIBLE OBJECT			
BACK	SIDE	BOTTOM	TOP
<u>2 1/4</u> (57)	<u>3</u> (76)	<u>6</u> (152)	<u>3</u> (76)

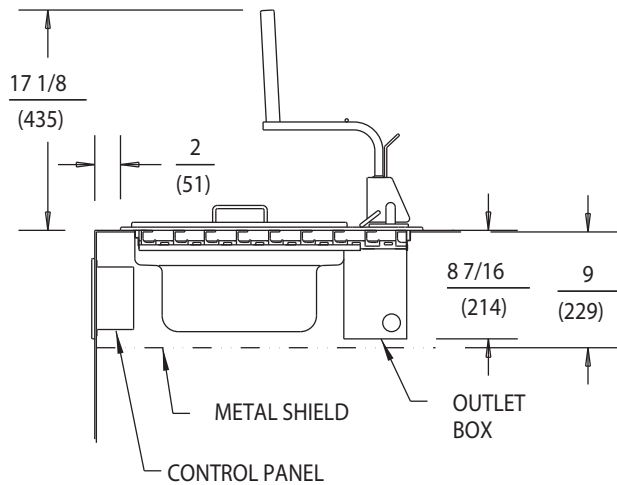

**F-556 ELECTRICAL SPECIFICATIONS:**

MODELS	VOLTS	WATTS	AMPS PER LINE 3 PHASE			AMPS	POWER
			L1	L2	L3	SINGLE PHASE	SUPPLY CORD
F-556	208	5750	-	-	-	27.7	NONE
F-556	204	5750	-	-	-	24.0	NONE

NOTE: Specifications are subject to change without notice. See installation instructions prior to installing the unit. This document is not for installation purposes. The installation of recognized component units requires additional evaluations to Underwriters Laboratories Inc. standards. Depending on the installation, clearances can be changes upon further evaluations to UL standards.

**THIS UNIT IS DESIGNED TO BE INSTALLED IN METAL COUNTERS ONLY**

Wells Bloomfield, LLC  
 2 Erik Circle, P.O. Box 280, Verdi, Nevada 89439 U.S.A.  
 U.S.A.: (775) 689-5700 · Main Fax (775) 689-5972  
 Canada: (877) 507-1700 · (905) 507-1700 · Fax (905) 507-1777  
 Export: (775) 689-5700 · Fax (775) 689-5975  
 www.wellsbloomfield.com  
 © 2007 Wells Bloomfield · Printed in the U.S.A.  
 12/07 · No. 38848

