

F-856 BUILT-IN FRYER

F-856 BUILT-IN FRYER



Wells F-856 Built-in Fryer is one of the most durable and versatile fryers in the industry. Swing-up elements allow the fry pots to be easily removed for cleaning, while the elements' low-watt density provides extended oil life. Fry two separate foods at the same time using the individual fry pots. The built-in Safety Test System enables periodic checks of the temperature-limiting thermostat.

Features

- **Swing-up elements**, located below the baskets, allow easy removal of the fry pots for cleaning. Elements are heavy-duty stainless steel with low watt density for longer oil life.
- **Element control housings** have a spring-loaded support rod to secure elements when in a raised position.
- **Safety Test System controls** are recessed in a one-piece, drawn, remote stainless steel panel.
- **Positive-off thermostats** control the elements, allowing for adjustable and more consistent temperatures. Signal lights indicate that the heating elements are energized.
- **Deep-drawn, removable fry pots** are made of nickel-plated steel and can hold up to fifteen pounds of oil each.
- **A manual reset safety thermostat** will shut off the heating element power and illuminate the signal light if an over-temperature condition is reached.
- **A terminal block** is provided for field wiring connection to the main power supply.
- **An auxiliary terminal block** allows connection to an external flame sensor fire suppression system.
- The F-856 is provided with a **Safety Test System** to enable periodic checks of the temperature-limiting thermostat.
- **Two full size, rear-hanging, interchangeable fry baskets** are provided and allow for product versatility.
- **Wellslok** allows for quick and easy installation in stainless steel countertops.
- The F-856 Fryer is **Underwriters Laboratories, Inc. recognized** and meets **NSF** International standards.
- **A one-year warranty** against defects covers parts and labor.

Specifications

Overall Dimensions:	Inches	MM
Width	24 13/16	630
Depth	23 9/16	598
Oil Capacity:	Lbs.	KG
F-856	30	14
Temperature Range:	Fahrenheit	Celsius
F-856	275° to 375°	135° to 191°
Pre-Heat Time to 350° F: 4 1/2 minutes		
Watts Per Hour to Maintain 350° F:		450
Typical Production:	Per Hour	
French Fries (2 oz. servings)	600	
Chicken (pounds)	40	
Weights:	Lbs.	KG
Installed	65	29
Shipping	77	35

Accessories / Options

Basket, half-size (2 per fry pot), 20161

Basket, full-size (1 per fry pot), 20162

Crumb Cradle, 20690

Fry Pot, replacement, 20169

Fry Pot Cover, 21010

Export

The following model is available for export and meets the standards for **CE**:

- F-856EU, 380-415V, 3NAC, 11.1 KW





DIMENSIONS: INCH
 (MM)

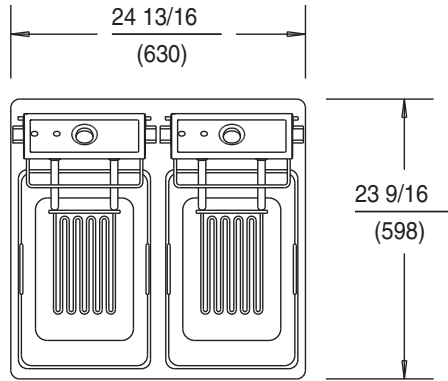

SUGGESTED CLEARANCE FROM UNIT TO THE NEAREST SURFACE			
BACK	SIDE	BOTTOM	FRONT
$2 \frac{1}{4}$	3	6	3
(57)	(76)	(152)	(76)

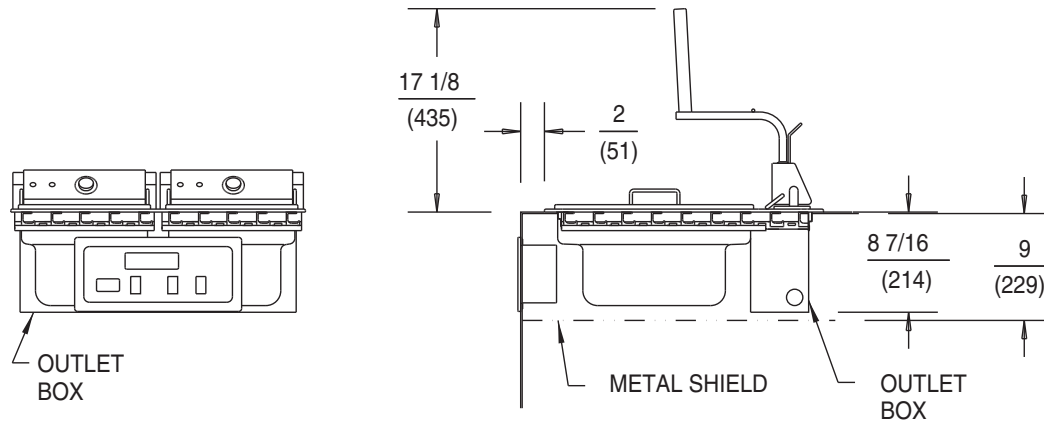

F-856 ELECTRICAL SPECIFICATIONS:

MODELS	VOLTS	WATTS	AMPS PER LINE 3 PHASE				AMPS SINGLE PHASE	POWER SUPPLY CORD
			L1	L2	L3	N		
F-856 W/STS	208	11500	31.9	31.9	31.9	NA	NONE	
F-856 W/STS	240	11500	27.6	27.6	27.6	NA	47.9	
F-856 W/STS	480	11500	13.8	13.8	13.8	NA	24.0	
● F-856EU	380-415	11100	16	16	16	0	-	

● Denotes export (EU) products.

NOTE: Specifications are subject to change without notice. See installation instructions prior to installing the unit. This document is not for installation purposes. The installation of recognized component units requires additional evaluations to Underwriters Laboratories Inc. standards. Depending on the installation, clearances can be changed upon further evaluations to UL standards.

THIS UNIT IS DESIGNED TO BE INSTALLED IN METAL COUNTERS ONLY

WELLS MANUFACTURING COMPANY
 2 ERIK CIRCLE, PO BOX 280, VERDI, NV 89439 U.S.A.
 USA PHONE: (775) 689-5700 • FAX: (775) 689-5972
 FOR ORDERS ONLY: (888) 356-5362 • FAX: (800) 356-5142
 www.wells-mfg.com
 © 2002 WELLS MANUFACTURING • PRINTED IN THE U.S.A.
 03/02 • REV(I) • PART NO. 37104

