

# F-886 BUILT-IN FRYER



F-886

Wells F-886 Built-in Autolift Fryer is one of the most durable and versatile fryers in the industry. Swing-up elements allow the fry pots to be easily removed for cleaning, while the elements' low-watt density provides extended oil life. Fry two separate foods at the same time using the individual fry pots. The built-in Safety Test System enables periodic checks of the temperature-limiting thermostat.

## Features

- The autolift fryer has an **adjustable one to fifteen minute push-button timer** for each fry pot that automatically lifts the basket from oil.
- **Swing-up elements**, located below the baskets, allow easy removal of the fry pots for cleaning. Elements are heavy-duty stainless steel with low watt density for longer oil life.
- **Element control housings** have a spring-loaded support rod to secure elements when in a raised position.
- **Safety Test System** and timer controls are recessed in a one-piece, drawn, remote stainless steel panel.
- **Positive-off thermostats** control the elements, allowing for adjustable and more consistent temperatures. Signal lights indicate that the heating elements are energized.
- **Deep-drawn, removable fry pots** are made of nickel-plated steel and can hold up to fifteen pounds of oil each.
- **A manual reset safety thermostat** will shut off the heating element power and illuminate the signal light if an over-temperature condition is reached.
- **A terminal block** is provided for field wiring connection to the main power supply.
- **An auxiliary terminal block** allows connection to an external flame sensor fire suppression system.
- The F-886 is provided with a **Safety Test System** to enable periodic checks of the temperature-limiting thermostat.
- **Two full size, rear-hanging, interchangeable fry baskets** are provided and allow for product versatility.
- **Wellslok** allows for quick and easy installation in stainless steel countertops.
- The F-886 Fryer is **Underwriters Laboratories, Inc. recognized** and meets **NSF International** standards.
- **A one-year warranty** against defects covers parts and labor.

## Specifications

<b>Overall Dimensions:</b>		<b>Inches</b>	<b>MM</b>
Width	24 13/16	630	
Depth	23 9/16	598	
<b>Oil Capacity:</b>		<b>Lbs.</b>	<b>KG</b>
F-886	30	14	
<b>Temperature Range:</b>		<b>Fahrenheit</b>	<b>Celsius</b>
F-886	275° to 375°	135° to 191°	
<b>Pre-Heat Time to 350° F:</b> 4 1/2 minutes			
<b>Watts Per Hour to Maintain 350° F:</b>		450	
<b>Typical Production:</b>		<b>Per Hour</b>	
French Fries (2 oz. servings)	600		
Chicken (pounds)	40		
<b>Weights:</b>		<b>Lbs.</b>	<b>KG</b>
Installed	78	35	
Shipping	89	40	

## Accessories / Options

- Basket, half-size (2 per fry pot), 20161
- Basket, full-size (1 per fry pot), 20162
- Crumb Cradle, 20690
- Fry Pot, replacement, 20169
- Fry Pot Cover, 21010





**DIMENSIONS:**      INCH  
                                    (MM)

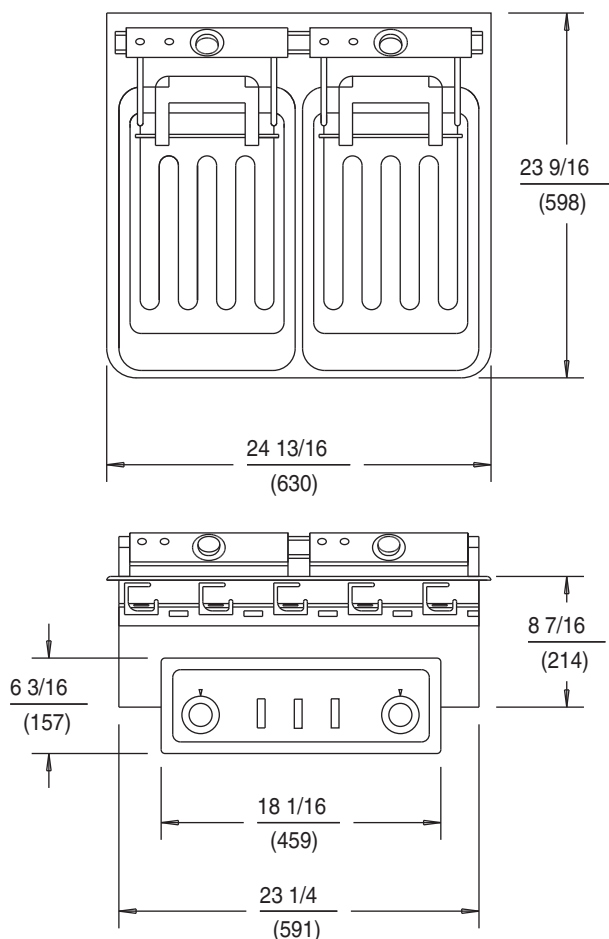

SUGGESTED CLEARANCE FROM UNIT TO THE NEAREST SURFACE			
BACK	SIDE	BOTTOM	FRONT
2 1/4 (57)	3 (76)	6 (152)	3 (76)

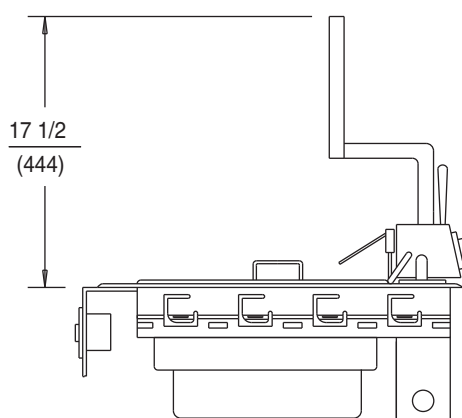

**F-886 ELECTRICAL SPECIFICATIONS:**

MODELS	VOLTS	WATTS	AMPS PER LINE 3 PHASE			AMPS SINGLE PHASE	POWER SUPPLY CORD
			L1	L2	L3		
F-886	208	11500	31.9	31.9	31.9	-	NONE
F-886	240	11500	27.6	27.6	27.6	47.9	NONE
F-886	480	11500	13.8	13.8	13.8	24.0	NONE

NOTE: Specifications are subject to change without notice. See installation instructions prior to installing the unit. This document is not for installation purposes. The installation of recognized component units requires additional evaluations to Underwriters Laboratories Inc. standards. Depending on the installation, clearances can be changed upon further evaluations to UL standards.

**THIS UNIT IS DESIGNED TO BE INSTALLED IN METAL COUNTERS ONLY**

WELLS MANUFACTURING COMPANY  
 2 ERIK CIRCLE, PO BOX 280, VERDI, NV 89439 U.S.A.  
 USA PHONE: (775) 689-5700 • FAX: (775) 689-5972  
 FOR ORDERS ONLY: (888) 356-5362 • FAX: (800) 356-5142  
 www.wells-mfg.com  
 © 2002 WELLS MANUFACTURING • PRINTED IN THE U.S.A.  
 03/02 • REV(F) • PART NO. 38860

