



Master Series Heavy Duty Griddle Top Range

Item: _____
 Quantity: _____
 Project: _____
 Approval: _____
 Date: _____

Master Series Heavy Duty Griddle Top Range

Models:

- | | | | | | |
|------------------------------------|------------------------------------|------------------------------------|--------------------------------------|--------------------------------------|--------------------------------------|
| <input type="checkbox"/> MST47-51R | <input type="checkbox"/> MST47-51S | <input type="checkbox"/> MST47-51T | <input type="checkbox"/> MST47-51R-E | <input type="checkbox"/> MST47-51S-E | <input type="checkbox"/> MST47-51T-E |
| <input type="checkbox"/> MST47-68R | <input type="checkbox"/> MST47-68S | <input type="checkbox"/> MST47-68T | <input type="checkbox"/> MST47-68R-E | <input type="checkbox"/> MST47-68S-E | <input type="checkbox"/> MST47-68T-E |

Valve Controlled Griddle Ranges

PHOTO NOT AVAILABLE

Standard Features:

- Stainless Steel Front, black powder coat epoxy side
- 6" (152mm) chrome steel adj. legs
- 7-1/2" (191mm) stainless steel front rail
- 1" (25 mm) thick steel griddle plate w/hi-lo valve and one, 30,000 BTU (8.78kW) "H" style cast iron burner for every 11" (28mm) of griddle width
- 2-5/16" (91mm) high welded steel splashguards, sides and back
- Clip-on stainless steel backsplash
- Removable front-mounted stainless steel grease receptacle
- Piezo Spark ignition for oven
- Fully porcelainized oven interior
- Storage base interior of aluminized steel
- 40,000 BTU (11.7kW) Nat., 35,000 BTU (10.25kW) Pro. cast iron oven burner
- Electric Spark ignition on all pilots Suffix -E models
- Sentry total flame failure protection for all burners

Optional Features:

- Stainless steel common front rail up to 68" (1728mm) wide (two or more units in at battery)
- Stainless steel oven interior

- Stainless steel left, right or both, sides or main back
- Fully grooved griddle (or grooved sections)
- Convection oven base, add suffix C to model # e.g. MST47-68RC, note convection oven base not available for MST47-51R or MST47-51R-E
- Additional oven rack
- Rear gas connection, 3/4" or 1" NPT.
- Gas regulator 3/4" or 1-1/4"
- Gas shut off valve; 3/4", 1" or 1-1/4" NPT
- Gas flex hose & quick disconnect (3/4", 1" or 1-1/4" NPT x 5') w/restraining device, please specify
- End caps and cover (NC) - Specify
- Swivel casters (4) with front brakes
- Polyurethane non-marking swivel casters w/ front brakes
- 6" (152mm) stainless steel adj. legs
- Dais base (not for use with RC oven)
- Storage base shelf of aluminized or stainless steel
- Stainless steel tubular high shelf, single or double deck
- Stainless steel backguard: 10" (354mm), 17" (432mm) or 33" (838mm)
- 230 V, 50 cycle components, RC motor and/or electric ignition (export)
- Celsius dial for oven thermostat, NC

Specifications:

Heavy duty gas ranges with ovens; The MST47-68 model, is 68" (1727mm) wide with a 68" (1727mm) griddle, and -51 models, have a full 51" (1295mm) griddle. Griddles are valve controlled 1" (25mm) thick, bordered side and rear with a continuous welded stainless steel splashguard. 38" (965mm) deep, including 7-1/2" (191mm) deep stainless steel front rail. Porcelain enamel oven interior with a 40,000 BTU (11.72kW) cast iron oven burner. -68R models have 2 ovens, -51R models have only one oven and a 17" (432mm) wide storage base on right. Stainless steel front with black powder coat epoxy sides. See chart for total BTU ratings. Sentry total flame failure protection for all burners. Natural or propane gas available. Also Available with 34" (864mm) storage base(s) w/doors in lieu of oven(s), suffix S, and Modular top, suffix T.



NOTE: Ranges supplied with casters must be installed with an approved restraining device.

Garland Commercial Industries, LLC
 185 East South Street
 Freeland, PA 18224
 Phone: (570) 636-1000
 Fax: (570) 636-3903

Garland Commercial Ranges Ltd
 1177 Kamato Road,
 Mississauga, Ontario
 L4W 1X4 CANADA
 Phone: 905-624-0260
 Fax: 905-624-5669



Product	Width: In(mm)	Depth: In(mm)	Height: In(mm) (w/ NSF Legs)	Height: In(mm) (w/o NSF Legs)	Oven/Storage Base Interior: in(mm)		
					Width	Depth	Height
MST47-68R	68(1727)	38(965)	36-3/8(924)	30-3/8(772)	26-1/4(667)	29(737)**	13-1/2(343)
MST47-51R	51(1295)	38(965)	36-3/8(924)	30-3/8(772)	26-1/4(667)	29(737)	13-1/2(343)
MST47-68S	68(1727)	38(965)	36-3/8(924)	30-3/8(772)	26(665)	30-1/2(773)	20-1/2(519)
MST47-51S	51(1295)	38(965)	36-3/8(924)	30-3/8(772)	26(665)	30-1/2(773)	20-1/2(519)
MST47-68T	68(1727)	38(965)	36-3/8(924) w/stand	9-1/2 (241) w/o stand*	N/A	N/A	N/A
MST47-51T	51(1295)	38(965)	36-3/8(924) w/stand	9-1/2 (241) w/o stand*	N/A	N/A	N/A

*Modular top has 1-1/2" seating flanges. **RC oven is 25" (635mm) deep

INPUT BTU/hr (kW)	MST47-51R (E)	MST47-68R/C(E)	MST47-51S/T(E)	MST47-68S/T(E)
Top Section	120,000 (35.14 kW)	180,000 (52.71 Kw)	120,000 (35.14 kW)	180,000(52.71 kW)
Oven(s)*** 1 burner each oven	40,000 (11.72 kW)	(2) 40,000 (11.72 kW)	—	—
Total	160,000 (46.85 kW)	260,000 (81.15 kW)	120,000 (35.14 kW)	180,000(52.71 kW)

RC=Range w/Convection Oven R=Range w/Oven S=Range w/Storage Base T=Modular Top

*** Oven rated 35,000 BTU (10.25) each for Propane Gas Please specify gas type when ordering.

INSTALLATION NOTES			Shipping: Wt (Lb/Kg) – Cu Ft (-51/ -68)
Combustible Wall Clearances ¹	Entry Clearances	Operating Pressure	MST47-51,68R 1160/527 – (80/110)
Sides: 11" (279mm) Back: 6" (152mm)	Crated: 39-1/4" (997mm) Uncrated: 34-1/4" (870mm)	Natural: 6" WC (15mbar) Propane: 10" WC (25mbar)	MST47-51,68S 980/445 – (80/110) MSY47-51,68T 800/364 – (30/40)

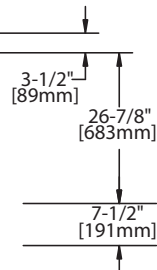
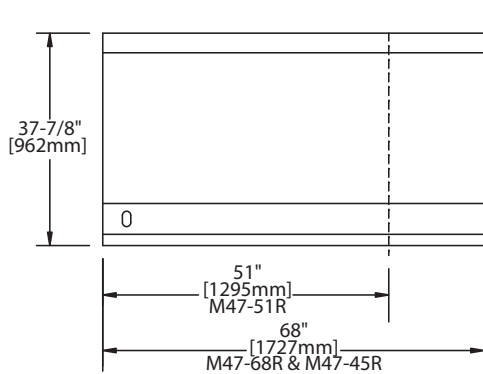

¹NOTE: Installation clearance reductions are applicable only where local codes permit.

Gas input ratings shown here are for installations up to 2,000 ft. (610m) above sea level. Specify altitudes over 2,000 ft. Electrical characteristics: **Each RC oven** –1/3 HP motor, 120 VAC, single phase, 3.4 amps (c/w 6 ft. (1.8m) power cord with NEMA 5-15P plug). 230 VAC export is direct connect, single phase, 50 Hz. **Electrical Spark Ignition** (suffix "E") – 0.1 amps for 115V 60Hz 1 Phase (c/w NEMA 5-15P cord & plug on models with out RC oven) and 0.05 amps for 240C 50Hz 1 phase.

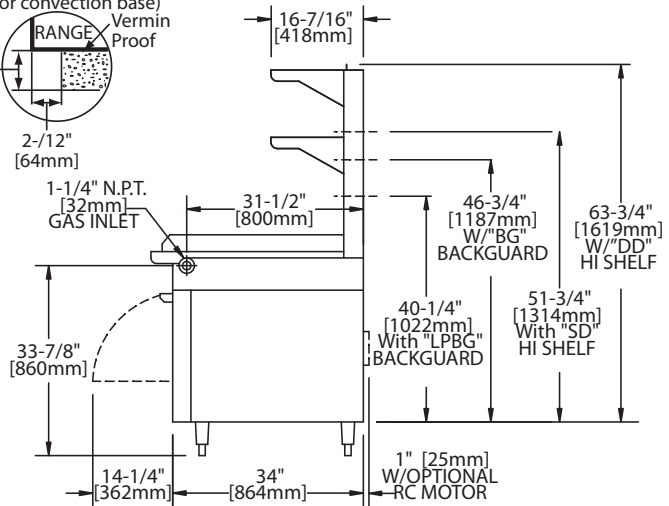
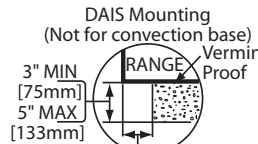
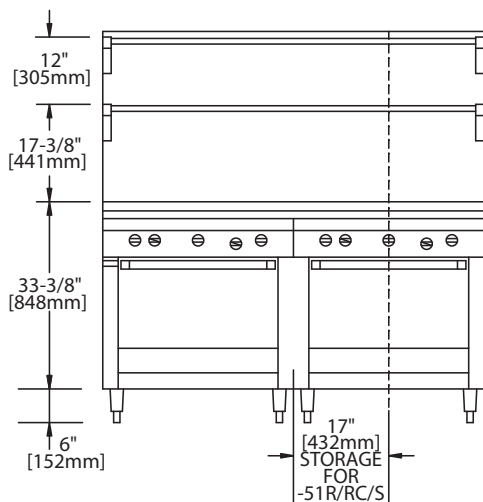

Form# M47-51R/S/T, -68R/S/T (03/03/10)